

**WARREN COUNTY
TRANSPORTATION IMPROVEMENT DISTRICT**

Resolution Number 2020 – 16

**A RESOLUTION AUTHORIZING THE AWARD OF CONSTRUCTION
CONTRACT FOR THE *WAR-CR21-0.23-0.41, PID 109613 (AKA MASON-
MONTGOMERY ROAD ACCESS MANAGEMENT PROJECT)***

WHEREAS, the WCTID is authorized by ORC Chapter 5540 (1) to finance, construct, maintain, repair and operate street, highway, and other transportation projects; and (2) to construct, reconstruct, improve, alter, and repair roads, highways, public places, buildings, and other infrastructure, and to implement and effect a regional approach to transportation improvements;

WHEREAS, the projects undertaken by the WCTID and exercise of its authority, pursuant to ORC Chapter 5540, are essential governmental functions and considered to contribute to the improvement of the prosperity, health, safety, and welfare of the people of the County and the State, and is consistent with and will promote industry, commerce, distribution, and research activity within the County, the region and the State;

WHEREAS, the WCTID recognizes, consistent with its charter, mission and in the development of its projects under ORC Chapter 5540 as established by its Board of Trustees, that it is a priority to engage and cooperate to the greatest extent practical in related efforts with the County and various political subdivisions therein;

WHEREAS, the WCTID committed to further develop, facilitate, fund and construct, in conjunction with ODOT as appropriate, certain necessary roadway improvements, for a public use within the County, and Deerfield Township (“Township”), including a roadway improvement project known as the: *WAR-CR21-0.23-0.41, PID 109613 (aka Mason-Montgomery Road Access Management Project)*, which includes improvements of a roadway open to and to serve the public, without charge, and as is further described and set forth in plans and documents on file with the WCTID, the WCEO (also specifically referred to hereafter as the “Project”); and, the Project is included in and part of the WCTID Program of Projects;

WHEREAS, the WCTID, in cooperation and coordination with Mason and the WCEO, invited and accepted bids to provide all labor and materials necessary to construct the Project in accordance with the project bid package, plans and specifications, which bids were opened and reviewed and tabulated by the WCEO on behalf of the WCTID, and accordingly determined that the bid submitted by Barrett Paving Materials, Inc. (“Barrett”), in the amount of \$191,382.30 was the apparent best, most responsive and responsible bid among those bids received on or before 11:00 a.m. local time, May 5th, 2020, in response to the invitation to bid by the WCTID;

WHEREAS, the WCTID, pursuant to ORC §5540.03 is authorized to take such actions, receive such funding, and enter into all agreements necessary or incidental to performance of its functions and the execution of its powers to effect its purposes and transportation projects under ORC Chapter 5540; and,

NOW, THEREFORE, BE IT RESOLVED that the WCTID Board of Trustees confirms and authorizes acceptance of the bid submitted by Barrett in the amount of \$191,382.30, as the apparent best most responsive and responsible bid among those bids received, on or before 11:00 a.m. local time, May 5th, 2020 in response to the invitation to bid by the WCTID to provide all labor and materials necessary to construct the Project in accordance with the project bid package, plans and specifications, and the WCTID Board hereby accordingly authorizes the WCTID Secretary-Treasurer to accept the bid and award the Project to Barrett, in the bid amount of \$191,382.30, and, in conjunction therewith, to take any and all further actions and to execute, to acknowledge, and to deliver or to accept, any and all such other and further documents or instruments, including, but not limited to, certificates, affidavits, ratifications, reaffirmations, and any and all other contract documents or instruments, all containing such provisions, clauses, covenants, agreements, warranties, terms, and conditions as the WCTID Chairperson or Secretary-Treasurer, in his sole and absolute discretion upon consultation with WCTID legal counsel and the WCEO, deems necessary or appropriate relative to the award and execution of the contract for the Project construction contracting services work, and, further, any appropriate change order(s), as may be determined appropriate and necessary by the WCTID Secretary-Treasurer in his sole and absolute discretion, upon consultation with WCTID legal counsel, not to exceed a total amount of 5% of the contract amount or \$9,596.12, and that the taking of any such action and the execution and delivery or acceptance of any such documents or instruments by the WCTID Chairperson or Secretary-Treasurer relative to any appropriate and required change orders, shall be conclusive evidence of the Board's determination that such actions are necessary in order for the WCTID to carry out the purposes of this resolution and of the authorization thereof by the Board.

It is found and determined that all formal actions of this Board concerning and relating to the adoption of this resolution were adopted in an open meeting of this Board, and that all deliberations of this Board that resulted in such formal action, were in meetings open to the public, in compliance with the law, including § 121.22 of the Ohio Revised Code and House Bill 197 provisions.

Adopted at a regularly adjourned meeting of the Board of Trustees of the Warren County Transportation Improvement District, Warren County, Ohio, this 8th day of May, 2020.

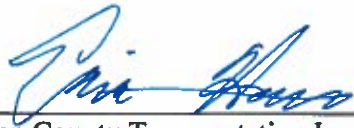

Warren County Transportation Improvement District
Presiding Trustee

Attest:



Warren County Transportation Improvement District
Secretary-Treasurer

Motion to Pass Resolution: *Eric Hansen*

Seconded by: *Tiffany Zindel*

G:\Cincinnati\DCS\Project\SRN\60603899_WCID_CR21\001\WAR\09613\Design\Roadway\Sheets\09613_GTO01.dgn Sheet 2/11/2020 8:56:03 AM christopher.jykins



LOCATION MAP

LATITUDE: N39°17'45" LONGITUDE: W84°18'55"



PORTION TO BE IMPROVED	_____
INTERSTATE HIGHWAY	_____
FEDERAL ROUTES	_____
STATE ROUTES	_____
COUNTY & TOWNSHIP ROADS	_____
OTHER ROADS	_____

DESIGN DESIGNATION

CURRENT ADT (2018)	51,380
DESIGN YEAR ADT (2040)	53,540
DESIGN HOURLY VOLUME (2040)	3,970
DIRECTIONAL DISTRIBUTION	52%
TRUCKS (24 HOUR B&C)	4%
DESIGN SPEED	35 MPH & 45 MPH
LEGAL SPEED	35 MPH & 45 MPH
DESIGN FUNCTIONAL CLASSIFICATION:	
06 MINOR COLLECTOR (URBAN)	
NHS PROJECT	NO

DESIGN EXCEPTIONS

NONE

UNDERGROUND UTILITIES
Contact Two Working Days Before You Dig

OHIO811, 8-1-1, or 1-800-362-2764
(Non-members must be called directly)

PLAN PREPARED BY:
AECOM
525 VINE STREET, SUITE 1800 CINCINNATI, OHIO 45202
(513) 651-3440

ENGINEERS SEAL:

SIGNED: *David L. Wormald*
DATE: 7-10-20

STANDARD CONSTRUCTION DRAWINGS				SUPPLEMENTAL SPECIFICATIONS		SPECIAL PROVISIONS	
BP-3.1	1/17/20	TC-41.20	10/18/13	800-2019	1/17/20		
		TC-41.30	10/18/13				
RM-3.1	7/20/18	TC-42.20	10/18/13	821	4/20/12		
		TC-52.20	7/20/18	832	10/19/18		
MT-95.31	4/19/19	TC-65.10	7/21/17	921	4/20/12		
MT-95.32	4/19/19	TC-65.11	7/21/17				
MT-95.60	4/19/19	TC-71.10	1/19/18				
MT-95.61	4/19/19						
MT-97.12	1/20/17						
MT-98.28	1/17/20						
MT-99.20	4/19/19						
MT-101.90	7/21/17						
MT-105.10	7/19/13						

STATE OF OHIO
DEPARTMENT OF TRANSPORTATION
WAR-21-0.23
MASON-MONTGOMERY RD.
DEERFIELD TOWNSHIP
WARREN COUNTY

INDEX OF SHEETS:

TITLE SHEET	1
TYPICAL SECTIONS	2
GENERAL NOTES	3
MAINTENANCE OF TRAFFIC	4-5
GENERAL SUMMARY	6
PLAN	7-8
PAVEMENT MARKING AND SIGNING PLAN	9

PROJECT DESCRIPTION

CONSTRUCTION OF A NEW CONCRETE MEDIAN ON MASON-MONTGOMERY ROAD (CR-21) TO CONTROL ACCESS TO EXISTING COMMERCIAL DRIVEWAYS NORTH OF ESCORT DRIVE. MILL AND OVERLAY EXISTING PAVEMENT, REPLACE SIGNS AND PAVEMENT MARKINGS.

EARTH DISTURBED AREAS

PROJECT EARTH DISTURBED AREA: 0.0 ACRES
ESTIMATED CONTRACTOR EARTH DISTURBED AREA: 0.125 ACRES
NOTICE OF INTENT EARTH DISTURBED AREA: NOT REQUIRED

2019 SPECIFICATIONS

THE STANDARD SPECIFICATIONS OF THE STATE OF OHIO, DEPARTMENT OF TRANSPORTATION, INCLUDING SUPPLEMENTAL SPECIFICATIONS LISTED IN THE PLANS AND CHANGES LISTED IN THE PROPOSAL SHALL GOVERN THIS IMPROVEMENT.

I HEREBY APPROVE THESE PLANS AND DECLARE THAT THE MAKING OF THIS IMPROVEMENT WILL NOT REQUIRE THE CLOSING TO TRAFFIC OF THE HIGHWAY AND THAT PROVISIONS FOR THE MAINTENANCE AND SAFETY OF TRAFFIC WILL BE AS SET FORTH ON THE PLANS AND ESTIMATES.

APPROVED: *Neil F. Junion*
DATE 3/10/20 WARREN COUNTY ENGINEER

FEDERAL PROJECT NO. E190562

PID NO. 109613

CONSTRUCTION PROJECT NO. N/A

RAILROAD INVOLVEMENT NONE

WAR-21-0.23

G:\Cincinnati\Projects\TRN\60603899_WCID_CR2\0001\WAR\09613\Design\Roadway\Sheets\09613_GY001.dgn_Sheet 2/11/2020 8:56:11 AM christopher.jykins

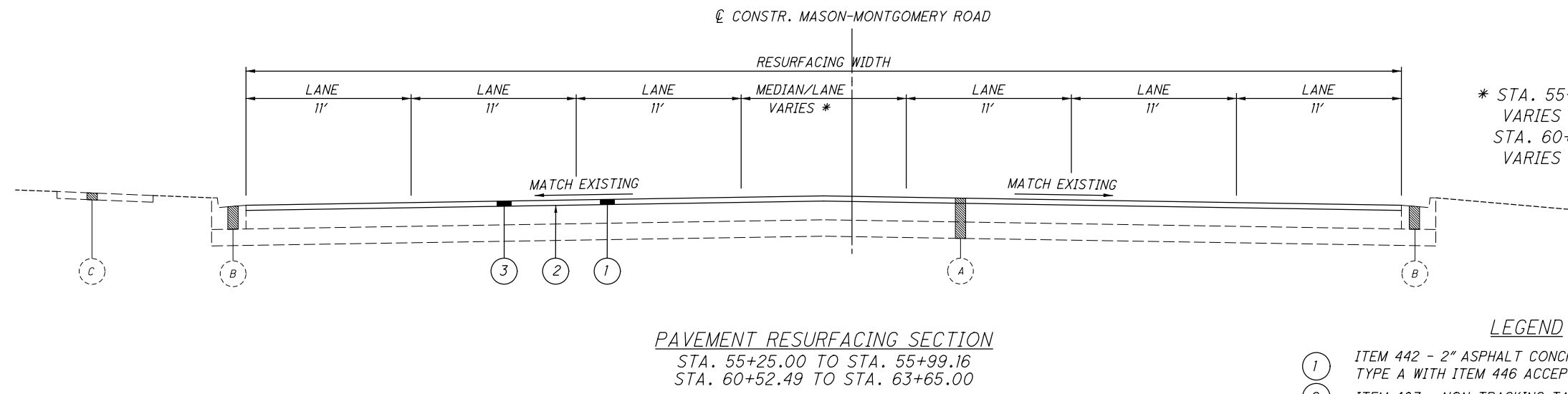
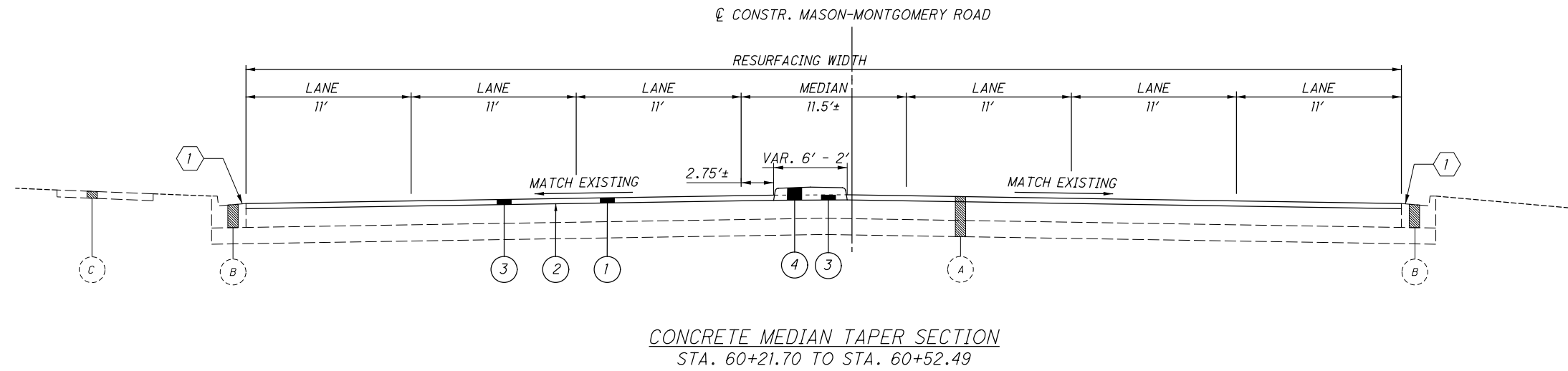
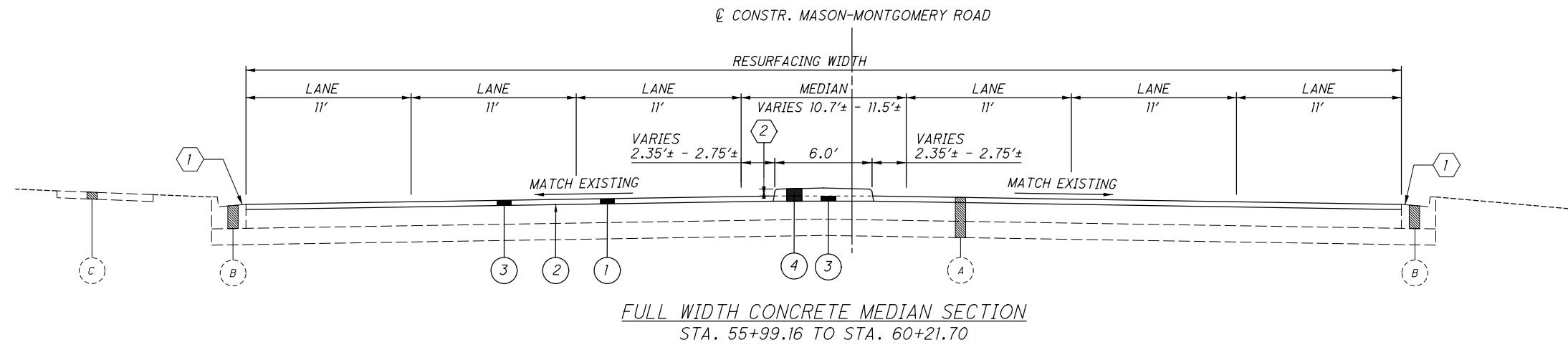

* STA. 55+25.00 TO STA. 55+99.16, VARIES 10.5' ± - 10.7' ±
STA. 60+52.49 TO STA. 63+65.00, VARIES 11.5' ± - 12.0' ±

NOTE:
(1) CONTRACTOR TO USE EXTREME CAUTION DURING PLANING AND RESURFACING OPERATIONS TO NOT DAMAGE EX. CURBING AND/OR COMBINATION CURB & GUTTER. ANY DAMAGES CAUSED BY THE CONTRACTOR, AS DETERMINED BY THE ENGINEER, SHALL BE APPROPRIATELY AND SATISFACTORILY REPAIRED AT THE CONTRACTOR'S SOLE EXPENSE.

- LEGEND**
- (1) ITEM 442 - 2" ASPHALT CONCRETE SURFACE COURSE, 12.5MM, TYPE A WITH ITEM 446 ACCEPTANCE
 - (2) ITEM 407 - NON-TRACKING TACK COAT (0.09 GAL./SY)
 - (3) ITEM 254 - PAVEMENT PLANING, ASPHALT CONCRETE, 2"
 - (4) ITEM 609 - CONCRETE MEDIAN
 - (A) EXISTING PAVEMENT WITH ASPHALT CONCRETE SURFACE
 - (B) EXISTING CURB AND GUTTER
 - (C) EXISTING WALK
 - (2) 6" TYPICAL, EXCEPT VARIES WITHIN LIMITS OF MEDIAN NOSE RAMP

G:\Cincinnati\DCS\Projects\TRN\60603899_WCID_CR2\ODOT\WAR\09613\Design\Roadway\Sheets\09613_GN001.dgn_Sheet 2/11/2020 8:56:12 AM christopher.jykins

UTILITIES

LISTED BELOW ARE ALL UTILITIES LOCATED WITHIN THE PROJECT CONSTRUCTION LIMITS TOGETHER WITH THEIR RESPECTIVE OWNERS. NO UTILITIES ARE TO BE DISTURBED.

CENTURYLINK
803 E. 12TH STREET
GREENVILLE, OH 45331
ATTN: DAVID KAPLAN
937-547-4255
DAVID.W.KAPLAN@CENTURYLINK.COM
NATIONALRELO@CENTURYLINK.COM

CHARTER COMMUNICATIONS
10920 KENWOOD ROAD
BLUE ASH, OH 45242
ATTN: KENT RIEGER
513-386-5499
KENT.RIEGER@CHARTER.COM

CINCINNATI BELL - AERIAL & PLACING
229 W. 7TH ST., BLDG. 121-900
CINCINNATI, OH 45202
ATTN: JASON NUNNALLEY
513-565-1418
JASON.NUNNALLEY@CINBELL.COM

CINCINNATI BELL TELEPHONE
221 E. 4TH STREET, BLDG. 121-900
CINCINNATI, OHIO 45201
ATTN: MARK CONNER
513-565-7043

CINCINNATI METROPOLITAN SEWER DISTRICT
1600 GEST STREET
CINCINNATI, OH 45204
ATTN: ROB FRANKLIN
513-557-7188
MSDUTILITYREVIEW@CINCINNATI-OH.GOV

DUKE ENERGY - ELECTRIC
2010 DANA AVENUE
ROOM EF 324
CINCINNATI, OHIO 45207
ATTN: TROY DITTMER
513-458-3844
TROY.DITTMER@DUKE-ENERGY.COM

DUKE ENERGY - GAS
139 E. 4TH STREET, ROOM 460A
CINCINNATI, OHIO 45202
ATTN: RICHARD HACKER
RICHARD.HACKER@DUKE-ENERGY.COM

GENERAL ELECTRIC (FIBER OPTIC)
8700 GOVERNOR'S HILL DRIVE
CINCINNATI, OHIO 45249
ATTN: JOHN DEHM
513-583-3488

GREATER CINCINNATI WATER WORKS
3845 EASTERN AVENUE
CINCINNATI, OHIO 45226
ATTN: KYLE BUCKLEY
513-591-7874
KYLE.BUCKLEY@GCWW.CINCINNATI-OH.GOV

LEVEL 3 COMMUNICATIONS
9490 MERIDIAN WAY
WEST CHESTER, OH 45069
ATTN: BRUCE MILLER
513-644-8943
BRUCE.MILLER@CENTURYLINK.COM
NATIONALRELO@CENTURYLINK.COM

MCI/VERIZON - FIBER OPTIC
120 RAVINE STREET
AKRON, OHIO 44303
ATTN: AL GUEST
330-253-8267
WARREN COUNTY WATER AND SEWER
406 JUSTICE DRIVE
LEBANON, OH 45036
ATTN: CHRIS BRAUSCH
513-695-1377

WINDSTREAM COMMUNICATIONS - KDL INC
929 MARTHA'S WAY
DAMAGE PREVENTION DEPARTMENT
HIAWATHA, IOWA 52233
ATTN: GAIL SCHMITZ
1-800-289-1901
LOCATE.DESK@WINDSTREAM.COM

THE LOCATION OF THE UNDERGROUND UTILITIES SHOWN ON THE PLANS ARE AS OBTAINED FROM THE OWNERS AS REQUIRED BY SECTION 153.64 O.R.C.

EXISTING PLANS

EXISTING PLANS FOR CR-21 MASON-MONTGOMERY RD. ARE AVAILABLE FOR REFERENCE FROM THE WARREN COUNTY ENGINEERS OFFICE.

PROFILE AND ALIGNMENT

PLACE THE PROPOSED PAVEMENT TO FOLLOW THE ALIGNMENT AND PROFILE OF THE EXISTING PAVEMENT.

PLACE THE PROPOSED ASPHALT CONCRETE OVERLAY WITH A UNIFORM THICKNESS OF 2.0" INCHES AS SHOWN ON THE TYPICAL SECTIONS.

SURVEYING PARAMETERS

SEE THIS SHEET FOR PROJECT CONTROL INFORMATION. A FIELD TOPOGRAPHIC SURVEY HAS NOT BEEN PERFORMED FOR THIS PROJECT. THE AS-BUILT LOCATIONS OF THE SOUTHBOUND CURB & GUTTER, SIGNS AND DRIVEWAYS SHALL BE FIELD VERIFIED BY THE CONTRACTOR.

USE THE FOLLOWING PROJECT CONTROL, VERTICAL POSITIONING, AND HORIZONTAL POSITIONING PARAMETERS FOR ALL SURVEYING:

PROJECT CONTROL

POSITIONING METHOD: ODOT VRS
MONUMENT TYPE: B

VERTICAL POSITIONING

ORTHOMETRIC HEIGHT DATUM: NAV 88
GEOID: 12A (CONUS)

HORIZONTAL POSITIONING

REFERENCE FRAME: NAD 83 (2011)
ELLIPSOID: GRS 80
MAP PROJECTION: LAMBERT
COORDINATE SYSTEM: STATE PLANE OH SOUTH
COMBINED SCALE FACTOR: 1.00009745
ORIGIN OF COORDINATE SYSTEM: 0.00, 0.00

USE THE POSITIONING METHODS AND MONUMENT TYPE USED IN THE ORIGINAL SURVEY TO RESTORE ANY MONUMENTS RELATED TO PRIMARY PROJECT CONTROL THAT ARE DAMAGED OR DESTROYED BY CONSTRUCTION ACTIVITIES. RESTORE THE DAMAGED OR DESTROYED MONUMENTS IN ACCORDANCE WITH CMS 623.

UNITS ARE IN U.S. SURVEY FEET.

WORK LIMITS

THE WORK LIMITS SHOWN ON THESE PLANS ARE FOR PHYSICAL CONSTRUCTION ONLY. PROVIDE THE INSTALLATION AND OPERATION OF ALL WORK ZONE TRAFFIC CONTROL AND WORK ZONE TRAFFIC CONTROL DEVICES REQUIRED BY THESE PLANS WHETHER INSIDE OR OUTSIDE THESE WORK LIMITS.

PROTECTION OF RIGHT-OF-WAY LANDSCAPING

PRIOR TO BEGINNING WORK, THE CONTRACTOR, THE PROJECT ENGINEER, AND A REPRESENTATIVE OF THE WARREN COUNTY ENGINEERS OFFICE WILL REVIEW AND RECORD ALL LANDSCAPING AND SIGNAGE ITEMS WITHIN THE RIGHT-OF-WAY (BOTH WITHIN AND OUTSIDE THE CONSTRUCTION LIMITS) A RECORD OF THIS REVIEW WILL BE KEPT IN THE PROJECT ENGINEER'S FILES. PRIOR TO FINAL ACCEPTANCE, A FINAL REVIEW OF LANDSCAPING ITEMS WILL BE MADE.

CONSTRUCT ALL ACTIVITIES, EQUIPMENT STORAGE, AND STAGING TO WITHIN THE CONSTRUCTION LIMITS. DO NOT USE PRIVATE PARKING LOTS OR DRIVEWAYS FOR PARKING OR STAGING OF EQUIPMENT AND MATERIALS.

ITEM 254 - PAVEMENT PLANING, ASPHALT CONCRETE

AN ESTIMATED QUANTITY OF ITEM 254 - PAVEMENT PLANING, ASPHALT CONCRETE HAS BEEN INCLUDED IN THE PLANS. THE APPROXIMATE DEPTH OF PAVEMENT PLANING SHALL BE TWO INCHES (2").

THE APPROXIMATE WIDTH OF THE PAVEMENT PLANING SHALL VARY.

ITEM 609, CONCRETE MEDIAN

THE CONCRETE MEDIAN SHALL BE AS SHOWN IN SCD RM-3.1, EXCEPT THAT THE WIDTH SHALL BE AS SHOWN ON THE PLAN SHEET AND THAT THE ASPHALT EMBEDMENT SHALL BE 2".

ITEM 620 DELINEATOR, POST SURFACE MOUNTED

THIS ITEM INCLUDES ALL LABOR, MATERIAL AND EQUIPMENT TO INSTALL FLEXIBLE SURFACE MOUNTED DELINEATOR POSTS TO THE CONCRETE MEDIAN AS SHOWN IN THE PLANS. THE POST SHALL BE FURNISHED BY AN APPROVED VENDOR ON THE ODOT QUALIFIED PRODUCTS LIST. THE BASE SHALL BE RIGIDLY MOUNTED TO THE CONCRETE SURFACE IN ACCORDANCE WITH MANUFACTURERS INSTRUCTIONS. PROVIDE HEAVY DUTY BASE MEETING NCHRP 350 REQUIREMENTS. POSTS SHALL BE 36" TALL, 3" WIDE, COLOR YELLOW. THE PROPOSED DELINEATOR SYSTEM SHALL BE APPROVED BY THE COUNTY ENGINEER IN WRITING 30 DAYS PRIOR TO INSTALLATION.

CALCULATED
CAL
CHECKED
DLW

GENERAL NOTES

WAR-21-0.23

3
9

G:\Cincinnati\DCS\Projects\TRN\60603899_WCID_CR2\000T\WAR\09613\Design\Roadway\Sheets\09613_GN002.dgn Sheet 2/11/2020 8:56:13 AM chrIstopher.jkIn

ITEM 614, MAINTAINING TRAFFIC

A MINIMUM OF ONE LANE OF TRAFFIC IN EACH DIRECTION SHALL BE MAINTAINED AT ALL TIMES BY USE OF THE EXISTING PAVEMENT AND THE COMPLETED PAVEMENT. ONE LANE CLOSER PER DIRECTION 8 PM TO 10 PM AND TWO LANE CLOSURES PER DIRECTION PERMITTED 10 PM TO 6 AM

NO WORK SHALL BE PERFORMED AND ALL LANES EXCEPT CENTER LANE SHALL BE OPEN TO TRAFFIC BETWEEN THE HOURS OF 6 AM AND 8 PM.

IN ADDITION, NO WORK SHALL BE PERFORMED AND ALL EXISTING LANES EXCEPT CENTER LANE SHALL BE OPEN TO TRAFFIC DURING THE FOLLOWING DESIGNATED HOLIDAYS OR EVENTS:

CHRISTMAS FOURTH OF JULY
NEW YEARS LABOR DAY
MEMORIAL DAY THANKSGIVING

THE PERIOD OF TIME THAT THE LANES ARE TO BE OPEN DEPENDS ON THE DAY OF THE WEEK ON WHICH THE HOLIDAY OR EVENT FALLS. THE FOLLOWING SCHEDULE SHALL BE USED TO DETERMINE THIS PERIOD:

DAY OF HOLIDAY TIME ALL LANES
OR EVENT MUST BE OPEN TO TRAFFIC

SUNDAY 12:00N FRIDAY THROUGH 6:00AM MONDAY
MONDAY 12:00N FRIDAY THROUGH 6:00AM TUESDAY
TUESDAY 12:00N MONDAY THROUGH 6:00AM WEDNESDAY
WEDNESDAY 12:00N TUESDAY THROUGH 6:00AM THURSDAY
THURSDAY 12:00N WEDNESDAY THROUGH 6:00AM FRIDAY
(THANKSGIVING ONLY)
6:00AM WEDNESDAY THROUGH 6:00AM MONDAY
FRIDAY 12:00N THURSDAY THROUGH 6:00AM MONDAY
SATURDAY 12:00N FRIDAY THROUGH 6:00AM MONDAY

SHOULD THE CONTRACTOR FAIL TO MEET ANY OF THESE REQUIREMENTS, THE CONTRACTOR SHALL BE ASSESSED A DISINCENTIVE OF \$1,000 FOR EACH HOUR OR PART OF AN HOUR FOR EACH LANE THAT IS NOT OPEN TO TRAFFIC.

LENGTH AND DURATION OF LANE CLOSURES AND RESTRICTIONS SHALL BE AT THE APPROVAL OF THE ENGINEER. IT IS THE INTENT TO MINIMIZE THE IMPACT TO THE TRAVELING PUBLIC. LANE CLOSURES OR RESTRICTIONS OVER SEGMENTS OF THE PROJECT IN WHICH NO WORK IS ANTICIPATED WITHIN A REASONABLE TIME FRAME, AS DETERMINED BY THE ENGINEER, SHALL NOT BE PERMITTED. THE LEVEL OF UTILIZATION OF MAINTENANCE OF TRAFFIC DEVICES SHALL BE COMMENSURATE WITH THE WORK IN PROGRESS.

THE CONTRACTOR SHALL PROVIDE, ERECT AND MAINTAIN SIGNS AND SIGN SUPPORTS, AS DETAILED IN THE OHIO MANUAL OF UNIFORM TRAFFIC CONTROL DEVICES, AND TYPE III BARRICADES AS REQUIRED.

ALL WORK AND TRAFFIC CONTROL DEVICES SHALL BE IN ACCORDANCE WITH C&MS 614 AND OTHER APPLICABLE PORTIONS OF THE SPECIFICATIONS, AS WELL AS THE OHIO MANUAL OF UNIFORM TRAFFIC CONTROL DEVICES. PAYMENT FOR ALL LABOR, EQUIPMENT AND MATERIALS SHALL BE INCLUDED IN THE LUMP SUM CONTRACT PRICE FOR ITEM 614, MAINTAINING TRAFFIC, UNLESS SEPARATELY ITEMIZED IN THE PLAN.

THE CONTRACTOR SHALL MAINTAIN EXISTING VEHICLE DETECTION AND INTERCONNECT CABLE OPERATION THROUGHOUT THE CONSTRUCTION PROCESS. IF AT ANY TIME THE INTERCONNECT BECOMES INOPERABLE, THE CONTRACTOR SHALL REPAIR ANY PROBLEMS TO THE SATISFACTION OF THE COUNTY WITHIN EIGHT HOURS OF RECEIVING NOTICE. WHEN A DETECTOR LOOP BECOMES INOPERABLE, THE CONTRACTOR SHALL TEMPORARILY REPAIR THE DAMAGED LOOP IF POSSIBLE. WHEN IT IS NOT POSSIBLE, THE CONTRACTOR SHALL PROVIDE TEMPORARY DETECTION. THIS SHALL CONSIST OF CAMERAS, MICROWAVE UNITS OR OTHER APPROVED DETECTION TYPES TO MAINTAIN THE OPERATION OF THE SIGNAL DETECTION. THE CONTRACTOR SHALL CONTACT THE COUNTY TO OBTAIN ANY REQUIRED TIMING CHANGES TO BE ENTERED UNTIL TEMPORARY DETECTION IS INSTALLED. NOTE THAT NO LOOP DETECTION SHALL BE INOPERABLE FOR MORE THAN 48 HOURS. ANY WORK THAT WILL NECESSITATE CLOSING A LANE SHALL BE COMPLETED BETWEEN THE HOURS OF 10 PM AND 6 AM.

ACCESS TO LOCAL DRIVES

CONTRACTOR SHALL MAINTAIN ACCESS TO LOCAL RESIDENCES AND BUSINESSES WITHIN THE PROJECT AREA THROUGHOUT THE DURATION OF THE PROJECT. COST OF MAINTAINING ACCESS SHALL BE INCIDENTAL TO ITEM 614, MAINTAINING TRAFFIC.

PLACEMENT OF ASPHALT CONCRETE

TWO-WAY TRAFFIC SHALL BE MAINTAINED AT ALL TIMES EXCEPT THAT ONE-WAY TRAFFIC WILL BE PERMITTED FOR MINIMUM PERIODS OF TIME CONSISTENT WITH THE REQUIREMENTS OF THE SPECIFICATIONS FOR PROTECTION OF COMPLETED ASPHALT CONCRETE COURSES.

WORK ZONE MARKINGS AND SIGNS

THE FOLLOWING ESTIMATED QUANTITIES HAVE BEEN CARRIED TO THE GENERAL SUMMARY FOR USE AT LOCATIONS IDENTIFIED BY THE ENGINEER FOR WORK ZONE PAVEMENT MARKINGS AND SIGNS PER THE REQUIREMENTS OF C&MS 614.04 AND 614.11.

- ITEM 614, WORK ZONE LANE LINE, CLASS I, 4", 740.06, TYPE I 0.57 MILE
- ITEM 614, WORK ZONE CENTERLINE, CLASS I, 740.06, TYPE I 0.29 MILE
- ITEM 614, WORK ZONE CHANNELIZING LINE, CLASS I, 8", 740.06, TYPE I 379 FT
- ITEM 614, WORK ZONE STOP LINE, CLASS I, 740.06, TYPE I 85 FT
- ITEM 614, WORK ZONE ARROW, CLASS I, 740.06, TYPE I 6 EACH
- ITEM 614, WORK ZONE WORD ON PAVEMENT, 72", CLASS I, 740.06, TYPE I 6 EACH

FLOODLIGHTING

FLOODLIGHTING OF THE WORK SITE FOR OPERATIONS CONDUCTED DURING NIGHTTIME PERIODS SHALL BE ACCOMPLISHED SO THAT THE LIGHTS DO NOT CAUSE GLARE TO THE DRIVERS ON THE ROADWAY. TO ENSURE THE ADEQUACY OF THE FLOODLIGHT PLACEMENT, THE CONTRACTOR AND THE ENGINEER SHALL DRIVE THROUGH THE WORK SITE EACH NIGHT WHEN THE LIGHTING IS IN PLACE AND OPERATIVE PRIOR TO COMMENCING ANY WORK. IF GLARE IS DETECTED, THE LIGHT PLACEMENT AND SHIELDING SHALL BE ADJUSTED TO THE SATISFACTION OF THE ENGINEER BEFORE WORK PROCEEDS.

PAYMENT FOR ALL LABOR, EQUIPMENT AND MATERIALS SHALL BE INCLUDED IN THE LUMP SUM CONTRACT PRICE FOR ITEM 614, MAINTAINING TRAFFIC.

ITEM 614 - LAW ENFORCEMENT OFFICER (WITH PATROL CAR) FOR ASSISTANCE DURING CONSTRUCTION OPERATIONS

USE OF LAW ENFORCEMENT OFFICERS (LEOS) BY CONTRACTORS OTHER THAN THE USES SPECIFIED BELOW WILL NOT BE PERMITTED AT PROJECT COST. LEOS SHOULD NOT BE USED WHERE THE OMUTCD INTENDS THAT FLAGGERS BE USED.

IN ADDITION TO THE REQUIREMENTS OF C&MS 614 AND THE OMUTCD, A UNIFORMED LEO WITH AN OFFICIAL PATROL CAR (CAR WITH TOP-MOUNTED EMERGENCY FLASHING LIGHTS AND COMPLETE MARKINGS OF THE APPROPRIATE LAW ENFORCEMENT AGENCY) SHALL BE PROVIDED FOR THE FOLLOWING TRAFFIC CONTROL TASKS:

DURING THE ENTIRE ADVANCE PREPARATION AND CLOSURE SEQUENCE WHERE COMPLETE BLOCKAGE OF TRAFFIC IS REQUIRED.

DURING THE TIME WHEN TRAFFIC NEEDS TO BE DIRECTED THROUGH AN ENERGIZED TRAFFIC SIGNAL CONTRARY TO THE SIGNAL DISPLAY (E.G., DIRECTING MOTORISTS THROUGH A RED LIGHT).

IN ADDITION TO THE REQUIREMENT OF C&MS 614 AND THE OMUTCD, A UNIFORMED LEO WITH AN OFFICIAL PATROL CAR (CAR WITH TOP-MOUNTED EMERGENCY FLASHING LIGHTS AND COMPLETE MARKINGS OF THE APPROPRIATE LAW ENFORCEMENT AGENCY) SHOULD BE PROVIDED FOR THE FOLLOWING TRAFFIC CONTROL TASKS AS APPROVED BY THE ENGINEER:

FOR LANE CLOSURES: DURING INITIAL SET-UP PERIODS, TEAR DOWN PERIODS, SUBSTANTIAL SHIFTS OF A CLOSURE POINT OR WHEN A NEW LANE CLOSURE ARRANGEMENTS ARE INITIATED FOR LONG-TERM LANE CLOSURES/SHIFTS (FOR THE FIRST AND LAST DAY OF MAJOR CHANGES IN TRAFFIC CONTROL SETUP).

IN GENERAL, LEOS SHOULD BE POSITIONED IN ADVANCE OF AND ON THE SAME SIDE AS THE LANE RESTRICTION OR AT THE POINT OF ROAD CLOSURE, AND TO MANUALLY CONTROL TRAFFIC MOVEMENTS THROUGH SIGNALIZED INTERSECTIONS IN WORK ZONES.

LEOS SHOULD NOT FORGO THEIR TRAFFIC CONTROL RESPONSIBILITIES TO APPREHEND MOTORISTS FOR ROUTINE TRAFFIC VIOLATIONS. HOWEVER, IF A MOTORIST'S ACTIONS ARE CONSIDERED TO BE RECKLESS, THEN PURSUIT OF THE MOTORIST IS APPROPRIATE.

THE LEOS WORK AT THE DIRECTION OF THE CONTRACTOR. THE CONTRACTOR IS RESPONSIBLE FOR SECURING THE SERVICES OF THE LEOS WITH THE APPROPRIATE AGENCIES AND COMMUNICATING THE INTENTIONS OF THE PLANS WITH RESPECT TO DUTIES OF THE LEOS. THE ENGINEER SHALL HAVE FINAL CONTROL OVER THE LEOS' DUTIES AND PLACEMENT, AND WILL RESOLVE ANY ISSUES THAT MAY ARISE BETWEEN THE TWO PARTIES.

ENSURE PROVIDED LEOS HAVE BEEN TRAINED APPROPRIATE TO THE JOB DECISIONS THEY ARE REQUIRED TO MAKE WHILE ON THE PROJECT, IN ACCORDANCE WITH C&MS 614.03.

THE LEO SHALL REPORT IN TO THE CONTRACTOR PRIOR TO THE START OF THE SHIFT, IN ORDER TO RECEIVE INSTRUCTIONS REGARDING THE SPECIFIC WORK ASSIGNMENTS DURING HIS/HER SHIFT. THE LEO IS EXPECTED TO STAY AT THE PROJECT SITE FOR THE ENTIRE DURATION OF HIS/HER SHIFT. THE LEO SHALL REPORT TO THE CONTRACTOR AT THE END OF HIS/HER SHIFT. SHOULD IT BE NECESSARY TO LEAVE THE PROJECT SITE, THE LEO SHALL NOTIFY THE ENGINEER. THE CONTRACTOR SHALL PROVIDE THE LEO WITH A TWO-WAY COMMUNICATION DEVICE WHICH SHALL BE RETURNED TO THE CONTRACTOR AT THE END OF HIS/HER SHIFT.

LEOS (WITH PATROL CAR) REQUIRED BY THE TRAFFIC MAINTENANCE TASKS ABOVE SHALL BE PAID FOR ON A UNIT PRICE (HOURLY) BASIS UNDER ITEM 614, LAW ENFORCEMENT OFFICER (WITH PATROL CAR) FOR ASSISTANCE. THE FOLLOWING ESTIMATED QUANTITIES HAVE BEEN CARRIED TO THE GENERAL SUMMARY:

ITEM 614, LAW ENFORCEMENT OFFICER WITH PATROL CAR FOR ASSISTANCE 200 HOURS

THE HOURS PAID SHALL INCLUDE ANY MINIMUM SHOW-UP TIME REQUIRED BY THE LAW ENFORCEMENT AGENCY INVOLVED.

ANY ADDITIONAL COSTS (ADMINISTRATIVE OR OTHERWISE) INCURRED BY THE CONTRACTOR TO OBTAIN THE SERVICES OF A LEO ARE INCLUDED WITH THE BID UNIT PRICE FOR ITEM 614, LAW ENFORCEMENT OFFICER WITH PATROL CAR FOR ASSISTANCE.

CALCULATED
CAL
CHECKED
DLW

MAINTENANCE OF TRAFFIC GENERAL NOTES

WAR-21-0.23

G:\Cincinnati\Projects\TRN\60603899_WCTID_CR2\000T\WAR\09613\Design\Roadway\Sheets\09613_GN003.dgn Sheet 2/11/2020 8:56:16 AM chrIstopher.jykins

NOTIFICATION OF TRAFFIC RESTRICTIONS

THROUGHOUT THE DURATION OF THE PROJECT, THE CONTRACTOR SHALL NOTIFY THE PROJECT ENGINEER IN WRITING OF ALL TRAFFIC RESTRICTIONS AND UPCOMING MAINTENANCE OF TRAFFIC CHANGES. THE CONTRACTOR SHALL ENSURE THE WRITING OF ALL TRAFFIC RESTRICTIONS AND UPCOMING MAINTENANCE OF TRAFFIC CHANGES. THE CONTRACTOR SHALL ENSURE THE WRITTEN NOTIFICATION IS SUBMITTED IN A TIMELY MANNER TO ALLOW THE PROJECT ENGINEER TO MEET THE REQUIRED TIME FRAMES SET FORTH IN THE TABLE BELOW TO INFORM THE SPECIAL HAULING PERMITS SECTION ([HTTP://WWW.WCEO.US/OPERATIONS/PERMITS.ASPX](http://www.wceo.us/operations/permits.aspx)) AND THE WARREN COUNTY ENGINEER'S OFFICE (WCEO). THIS NOTIFICATION SHALL BE RECEIVED BY THE PROJECT ENGINEER PRIOR TO THE PHYSICAL SETUP OF ANY APPLICABLE SIGNS OR MESSAGE BOARDS.

INFORMATION SHOULD INCLUDE, BUT IS NOT LIMITED TO, ALL CONSTRUCTION ACTIVITIES THAT IMPACT OR INTERFERE WITH TRAFFIC AND SHALL LIST THE SPECIFIC LOCATION, TYPE OF WORK, ROAD STATUS, DATE AND TIME OF RESTRICTION, DURATION OF RESTRICTION, NUMBER OF LANES MAINTAINED, NUMBER OF LANES CLOSED, MINIMUM VERTICAL CLEARANCE, MINIMUM WIDTH OF DRIVABLE PAVEMENT, DETOUR ROUTES, IF APPLICABLE, AND ANY OTHER INFORMATION REQUESTED BY THE PROJECT ENGINEER.

NOTIFICATION TIME TABLE

ITEM	DURATION OF CLOSURE	NOTICE DUE TO PERMITS & PIO
RAMP & ROAD CLOSURES	>= 2 WEEKS	21 CALENDAR DAYS PRIOR TO CLOSURE
	> 12 HOURS & < 2 WEEKS	14 CALENDAR DAYS PRIOR TO CLOSURE
	< 12 HOURS	4 CALENDAR DAYS PRIOR TO CLOSURE
LANE CLOSURES & RESTRICTIONS	>= 2 WEEKS	14 CALENDAR DAYS PRIOR TO CLOSURE
	< 2 WEEKS	5 BUSINESS DAYS PRIOR TO CLOSURE
START OF CONSTRUCTION & TRAFFIC PATTERN CHANGES	N/A	14 CALENDAR DAYS PRIOR TO IMPLEMENTATION

ANY UNFORESEEN CONDITIONS NOT SPECIFIED IN THE PLANS REQUIRING TRAFFIC RESTRICTIONS SHALL ALSO BE REPORTED TO THE PROJECT ENGINEER USING THE NOTIFICATION TIME TABLE.

SUGGESTED SEQUENCE OF CONSTRUCTION

DURING NIGHT TIME HOURS, MILL CENTER LANE TO PREPARE FOR CONCRETE MEDIAN. CONSTRUCT CONCRETE MEDIAN. MILL AND FILL INDIVIDUAL TRAFFIC LANES ONE-BY-ONE WHILE MAINTAINING TRAFFIC. PLACE PAVEMENT MARKINGS AND SIGNS.

CALCULATED
CAL
CHECKED
DLW

MAINTENANCE OF TRAFFIC GENERAL NOTES

WAR-21-0.23



SHEET NUMBER										PARTICIPATION				ITEM	ITEM EXT	GRAND TOTAL	UNIT	DESCRIPTION	SEE SHEET NO.	CALCULATED	CAL	CHECKED	DLW
																		PAVEMENT					
														254	01000	7418	SY	PAVEMENT PLANING, ASPHALT CONCRETE, 2"					
														407	20000	641	GAL	NON-TRACKING TACK COAT					
														609	72000	295	SY	CONCRETE MEDIAN					
														442	10000	395	CY	ASPHALT CONCRETE SURFACE COURSE, 12.5MM, TYPE A (446)					
																		TRAFFIC CONTROL	9				
														620	60000	35	EACH	DELINEATOR, POST SURFACE MOUNTED					
														621	00100	77	EACH	RPM					
														621	54000	77	EACH	RAISED PAVEMENT MARKER REMOVED					
														630	03100	130	FT	GROUND MOUNTED SUPPORT, NO. 3 POST					
														630	08600	10	EACH	SIGN POST REFLECTOR					
														630	80100	57	SF	SIGN, FLAT SHEET					
														630	84900	7	EACH	REMOVAL OF GROUND MOUNTED SIGN AND DISPOSAL					
														630	86002	5	EACH	REMOVAL OF GROUND MOUNTED POST SUPPORT AND DISPOSAL					
														642	01290	8	EACH	LANE ARROW					
														642	01390	4	EACH	WORD ON PAVEMENT, 72"					
														644	00204	0.54	MILE	LANE LINE, 6"					
														644	00300	0.29	MILE	CENTER LINE					
														644	00404	372	FT	CHANNELIZING LINE, 12"					
														644	00500	85	FT	STOP LINE					
														644	00700	62	FT	TRANSVERSE/DIAGONAL LINE					
														644	01510	23	FT	DOTTED LINE, 6"					
														644	01520	169	FT	DOTTED LINE, 12"					
																		MAINTENANCE OF TRAFFIC	4				
														614	11110	200	HOURL	LAW ENFORCEMENT OFFICER WITH PATROL CAR FOR ASSISTANCE					
														614	20200	0.57	MILE	WORK ZONE LANE LINE, CLASS I, 740.06, TYPE I					
														614	21200	0.29	MILE	WORK ZONE CENTER LINE, CLASS I, 740.06, TYPE I					
														614	23400	379	FT	WORK ZONE CHANNELIZING LINE, 8", CLASS I, 740.06, TYPE I					
														614	26400	85	FT	WORK ZONE STOP LINE, CLASS I, 740.06, TYPE I					
														614	30400	6	EACH	WORK ZONE ARROW, CLASS I, 740.06, TYPE I					
														614	31400	6	EACH	WORK ZONE WORD ON PAVEMENT, 72", CLASS I, 740.06, TYPE I					
																		INCIDENTALS					
														614	11000	LS		MAINTAINING TRAFFIC			4		
														623	10000	LS		CONSTRUCTION LAYOUT STAKES AND SURVEYING			3		
														624	10000	LS		MOBILIZATION					

GENERAL SUMMARY

WAR-21-0.23



G:\Cincinnati\Projects\TRN\60603899_WCID_CR2\000T\WAR\09613\Design\Roadway\Sheets\09613_G001.dgn_Sheet 2/11/2020 8:56:17 AM christopher.jenkins

G:\Cincinnati\Projects\TRN\60603899_WCID.CR2\0001\WAR\09613\Design\Roadway\Sheets\09613.GP001.dgn Sheet 2/11/2020 8:56:21AM christopher.lykins

CALCULATED
CAL
CHECKED
DLW

0 20 40
HORIZONTAL
SCALE IN FEET

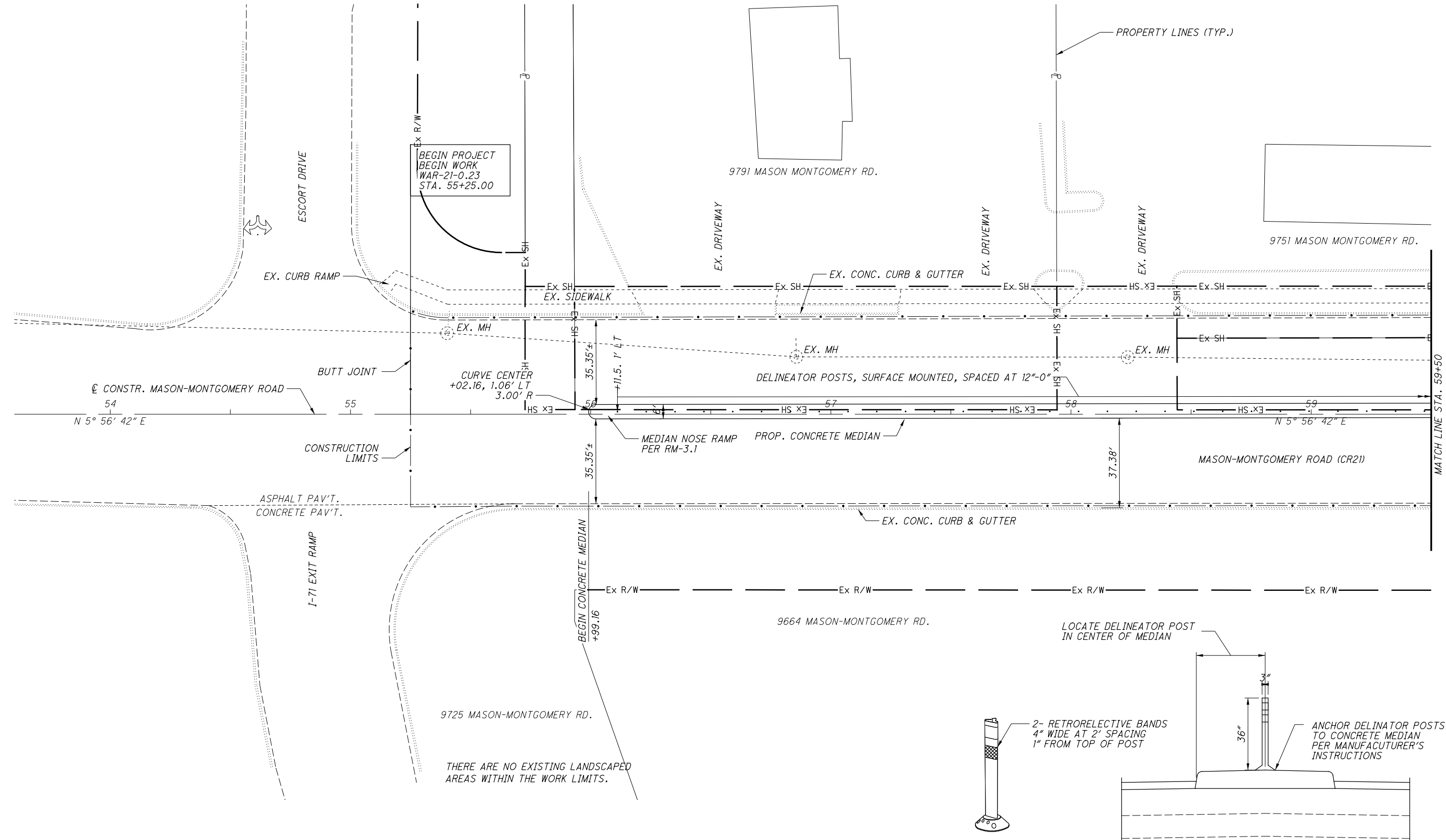

NOTE:
ALL PROPERTY AND RIGHT OF WAY LINES SHOWN ARE APPROXIMATIONS BASED ON
COUNTY AUDITOR INFORMATION ANDE DOES NOT REPRESENT A BOUNDARY SURVEY.

PLAN
BEGIN PROJECT TO STA. 59+50

WAR-21-0.23

G:\Cincinnati\DCS\Projects\TRN\60603899_WCID_Cr2\0001\WAR\09613\Design\Roadway\Sheets\09613.GP002.dgn Sheet 2/11/2020 8:56:23 AM christopher.lykins

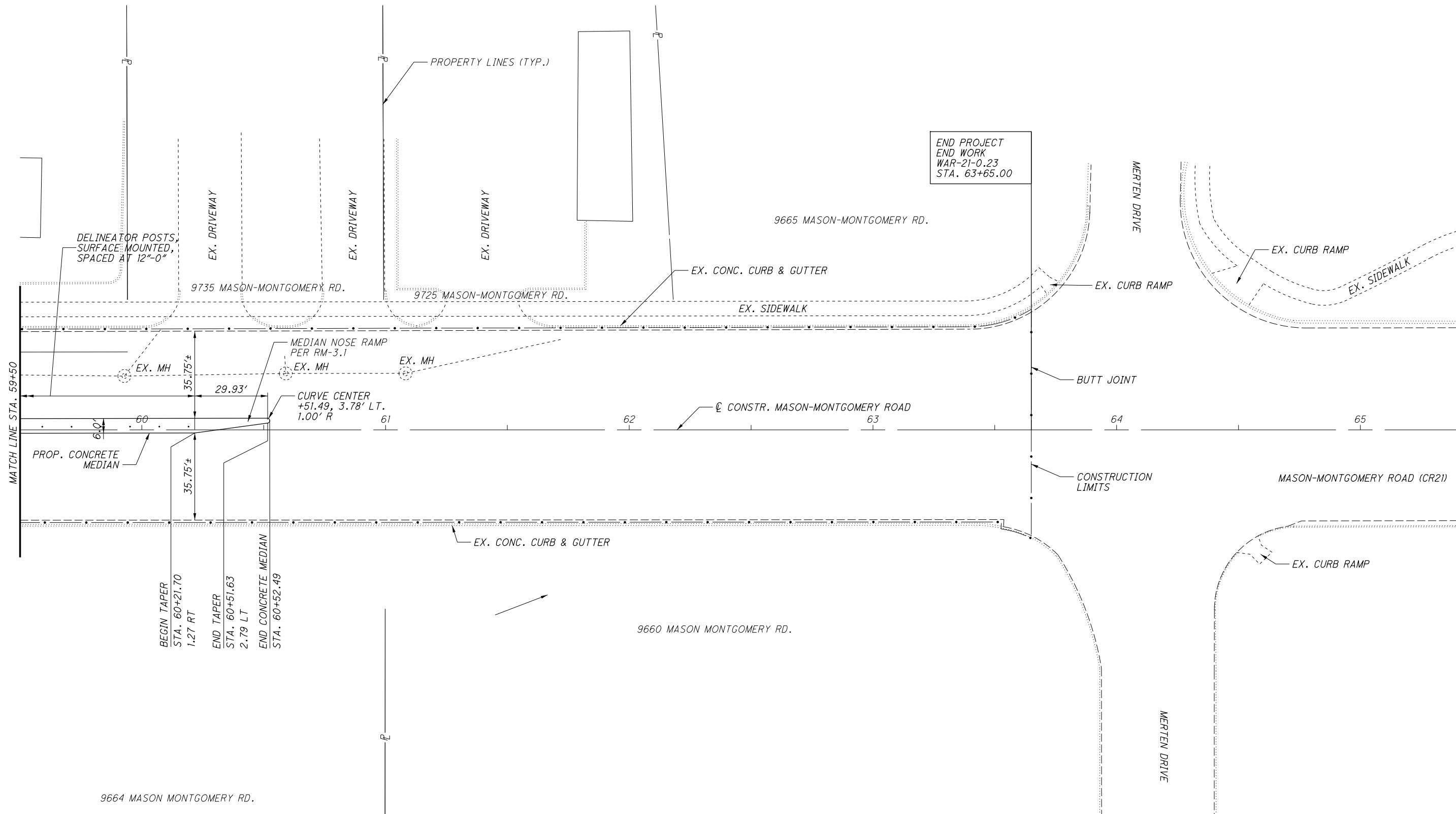

NOTE:
ALL PROPERTY AND RIGHT OF WAY LINES SHOWN ARE APPROXIMATIONS BASED
ON COUNTY AUDITOR INFORMATION AND DOES NOT REPRESENT A BOUNDARY SURVEY.

CALCULATED
CAL
CHECKED
DLW

0 20 40
HORIZONTAL
SCALE IN FEET

N

PLAN
STA. 59+50 TO END PROJECT

WAR-21-0.23

8
9

G:\Cincinnati\Projects\TRN\60603899_WCID_CR2\000T\WAR\09613\Design\Traffic\Sheets\09613_TP001.dgn Sheet 2/11/2020 8:56:27 AM christopher.jenkins

BEGIN PROJECT
BEGIN WORK
STA 55+25.00

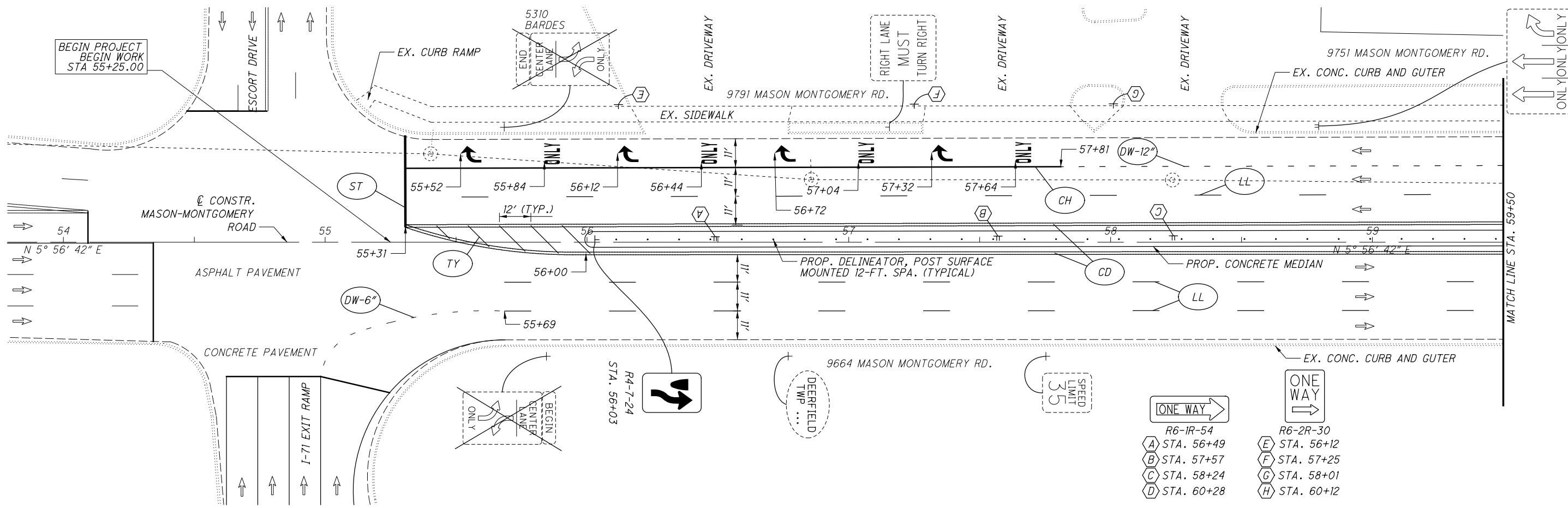

CALCULATED
CAL
CHECKED
DLW

0 20 40
HORIZONTAL
SCALE IN FEET

N

SIGNING AND PAVEMENT MARKING PLAN

WAR-21-0.23

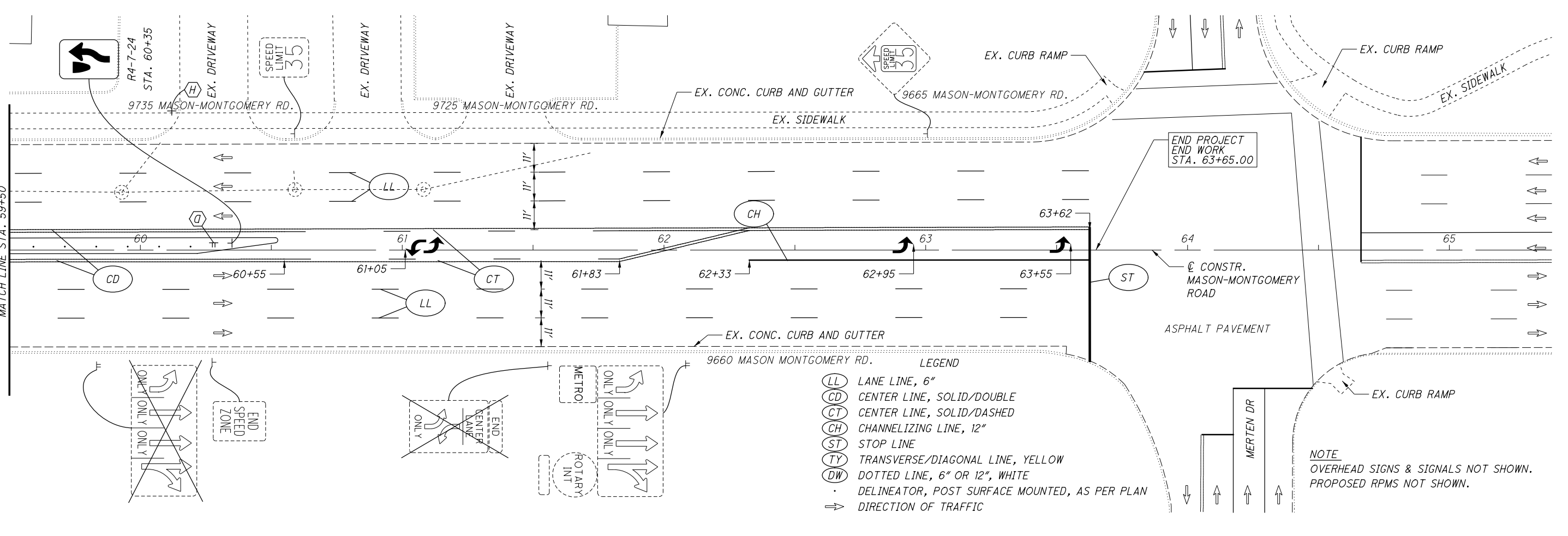

- R6-1R-54
- A STA. 56+49
- B STA. 57+57
- C STA. 58+24
- D STA. 60+28
- R6-2R-30
- E STA. 56+12
- F STA. 57+25
- G STA. 58+01
- H STA. 60+12

- LEGEND
- (LL) LANE LINE, 6"
 - (CD) CENTER LINE, SOLID/DOUBLE
 - (CT) CENTER LINE, SOLID/DASHED
 - (CH) CHANNELIZING LINE, 12"
 - (ST) STOP LINE
 - (TY) TRANSVERSE/DIAGONAL LINE, YELLOW
 - (DW) DOTTED LINE, 6" OR 12", WHITE
 - DELINEATOR, POST SURFACE MOUNTED, AS PER PLAN
 - ➔ DIRECTION OF TRAFFIC

NOTE
OVERHEAD SIGNS & SIGNALS NOT SHOWN.
PROPOSED RPMS NOT SHOWN.

LEGAL NOTICE TO CONTRACTORS

The Warren County Transportation Improvement District (WCTID), in cooperation and coordination with the Warren County Engineer's Office will be accepting sealed bids for the furnishing of all labor, equipment, and materials needed to construct ODOT PID **109613: WAR-CR21-0.23-0.41**, (aka Mason-Montgomery Road Access Management Improvements) in accordance with the applicable Ohio Department of Transportation Construction and Material Specifications (effective January 1, 2019 and its revisions and supplements), Standard Construction Drawings, Standard Bridge Drawings, Ohio Manual of Uniform Traffic Control, The State of Ohio Department of Transportation Bridge Design Manual, and other applicable standards in force on the date of letting and in accordance with the Project Specifications and Construction Plans on file in the office of the Warren County Engineer. This project is the construction of a new concrete median on Mason-Montgomery Road (CR-21) to control access to existing commercial driveways north of Escort Drive, mill and Overlay existing pavement, replace signs and pavement markings in Deerfield Township, Warren County, Ohio. The Engineer's estimate for this project is Two Hundred Thousand and no cents (\$200,000.00).

All bids must be submitted in conformance with the requirements of the Project Specifications and in a sealed envelope marked: ODOT PID **109613: WAR-CR21-0.23-0.41**, and received in the office of the Warren County Engineer, 210 W Main Street, Lebanon, Ohio 45036, no later than 11:00 a.m. Local Time on Tuesday, May 5th, 2020 after which time all bids shall be opened and read publicly.

Instructions to Bidders, Specifications, Bid Documents, and Plans detailing the terms and conditions of the proposed improvement may be obtained after April 13, 2020 and are available online at the Warren County's Website at <https://www.co.warren.oh.us/Commissioners/Bids/Default.aspx>. Questions regarding the technical specifications should be directed to Dan Corey, P.E., Warren County Engineer's Office at 513-431-1229 or Dan.Corey@co.warren.oh.us. **Each contractor shall be ODOT prequalified.**

This notice is posted on the Warren County Government internet site. The Warren County Government Web Site can be accessed by logging onto the internet and typing in the following address <https://www.co.warren.oh.us/Commissioners/Bids/Default.aspx>. Please contact the Warren County Commissioners Office at (513) 695- 1250 if you have trouble with this procedure or if you need additional information on accessing bid project information on our web site. If the contractor would like to bid the project, they must contact kiana.hawk@co.warren.oh.us to be put on the bidders list. Please be aware that if you are downloading this document to bid this project, addendums to the scope may be issued prior to the bid date. In order to stay updated on any change, please email Kiana Hawk in the Commissioner's Office at Kiana.Hawk@co.warren.oh.us with your contact information.

WCTID reserves the right to waive any informalities, reject any or all bids and to hold such bids for a period of sixty (60) days before taking any action thereon, and to award a contract to the best, most responsive and responsible bidder.

**WARREN COUNTY
TRANSPORTATION IMPROVEMENT
DISTRICT**

BID PACKAGE

***WAR-CR21 0.23-0.41
Mason-Montgomery Rd Access Management
Project***

ODOT PID 109613

**DEERFIELD TOWNSHIP
WARREN COUNTY, OHIO**

DBE GOAL: 5%

TABLE OF CONTENTS

WAR-CR21 0.23-0.41 MASON-MONTGOMERY RD ACCESS MANAGEMENT PROJECT ODOT PID 109613

SECTION I	<i>Notice to Contractors</i>	<i>1 Page</i>
SECTION II	<i>General Instructions to Bidders</i>	<i>5 Pages</i>
SECTION III	<i>General Provisions</i>	<i>15 Pages</i>
SECTION IV	Federal and State Requirements	23 Pages
SECTION V	<i>Bid Proposal and Bid Guaranty</i>	<i>7 Pages</i>
SECTION VI	<i>Affidavits and Change Order Form</i>	<i>5 Pages</i>
SECTION VII	<i>Prevailing Wage Rates</i>	<i>99 Pages</i>
SECTION VIII	<i>Contract No. 20-01</i>	<i>2 Pages</i>
SECTION IX	Special Provisions /Technical Specifications	9 Pages
Total		166 Pages

SECTION I

Notice to Contractors

LEGAL NOTICE TO CONTRACTORS

The Warren County Transportation Improvement District (WCTID), in cooperation and coordination with the Warren County Engineer's Office will be accepting sealed bids for the furnishing of all labor, equipment, and materials needed to construct ODOT PID **109613: WAR-CR21-0.23-0.41**, (aka Mason-Montgomery Road Access Management Improvements) in accordance with the applicable Ohio Department of Transportation Construction and Material Specifications (effective January 1, 2019 and its revisions and supplements), Standard Construction Drawings, Standard Bridge Drawings, Ohio Manual of Uniform Traffic Control, The State of Ohio Department of Transportation Bridge Design Manual, and other applicable standards in force on the date of letting and in accordance with the Project Specifications and Construction Plans on file in the office of the Warren County Engineer. This project is the construction of a new concrete median on Mason-Montgomery Road (CR-21) to control access to existing commercial driveways north of Escort Drive, mill and Overlay existing pavement, replace signs and pavement markings in Deerfield Township, Warren County, Ohio. The Engineer's estimate for this project is Two Hundred Thousand and no cents (\$200,000.00).

All bids must be submitted in conformance with the requirements of the Project Specifications and in a sealed envelope marked: ODOT PID **109613: WAR-CR21-0.23-0.41**, and received in the office of the Warren County Engineer, 210 W Main Street, Lebanon, Ohio 45036, no later than 11:00 a.m. Local Time on Tuesday, May 5th, 2020 after which time all bids shall be opened and read publicly.

Instructions to Bidders, Specifications, Bid Documents, and Plans detailing the terms and conditions of the proposed improvement may be obtained after April 13, 2020 and are available online at the Warren County's Website at <https://www.co.warren.oh.us/Commissioners/Bids/Default.aspx>. Questions regarding the technical specifications should be directed to Dan Corey, P.E., Warren County Engineer's Office at 513-431-1229 or Dan.Corey@co.warren.oh.us. **Each contractor shall be ODOT prequalified.**

This notice is posted on the Warren County Government internet site. The Warren County Government Web Site can be accessed by logging onto the internet and typing in the following address <https://www.co.warren.oh.us/Commissioners/Bids/Default.aspx>. Please contact the Warren County Commissioners Office at (513) 695- 1250 if you have trouble with this procedure or if you need additional information on accessing bid project information on our web site. If the contractor would like to bid the project, they must contact kiana.hawk@co.warren.oh.us to be put on the bidders list. Please be aware that if you are downloading this document to bid this project, addendums to the scope may be issued prior to the bid date. In order to stay updated on any change, please email Kiana Hawk in the Commissioner's Office at Kiana.Hawk@co.warren.oh.us with your contact information.

WCTID reserves the right to waive any informalities, reject any or all bids and to hold such bids for a period of sixty (60) days before taking any action thereon, and to award a contract to the best, most responsive and responsible bidder.

SECTION II

General Instructions to Bidders

GENERAL INSTRUCTIONS TO BIDDERS FOR PUBLIC IMPROVEMENTS

**ODOT PID 109613: WAR-CR21-0.23-0.41,
(aka Mason-Montgomery Road Access Management Improvements)**

**DEERFIELD TOWNSHIP
WARREN COUNTY, OHIO**

ODOT PID 109613

SECTION 100 ITEM BID (DESCRIPTION OF WORK)

- 100.1** Work under consideration for bidding purposes shall be that Work as shown on the Project Plans and Specifications to provide all the labor and materials necessary to construct **WAR-CR21-0.23-0.41 (aka Mason-Montgomery Road Access Management Improvements)**, located in DEERFIELD TOWNSHIP AND CITY OF MASON, in Warren County, Ohio, in accordance with the Project Specifications and Construction Plans (the "Specifications") on file in the office of the Warren County Engineer. This project is the relocation of Columbia Road to the east of its current location and the upgrade and realignment of Western Row Road west of I-71 through the first bend to the east, with capacity improvements at the intersection with the existing interstate ramps and Kings Island Drive, in Deerfield Township and the City of Mason, Warren County, Ohio.
- 100.2** All bids submitted for consideration by the WCTID must comply with these instructions in order to be considered. These instructions set forth minimum requirements as the terms and conditions of the purchase. Therefore, if any time frames, bid bond or other surety requirements set forth herein are in conflict with stated requirements in the Specifications, the specification requirements shall prevail. It is intended that the Specifications governing this project (and any bidding requirements and conditions) and any ODOT specifications or references to the Ohio Revised Code as set forth herein, and any attachments(s) or documents incorporated by reference herein, be constructed harmoniously wherever possible in order to carry out the full intent and purposes of the WCTID with respect to this project. But if there is conflict or inconsistency between any provision(s) of the ODOT specifications or references to the Ohio Revised Code and those contained herein, the provisions(s) granting rights, remedies, discretions and/or latitude to the WCTID, or imposing the greater duty, standard, responsibility and/or obligation on the Contractor shall govern.
- 100.3** It is intended that the Specifications governing this project (and any bidding requirements and conditions) and any ODOT specifications or references to the Ohio Revised Code as set forth herein, and any attachments(s) or documents incorporated by reference herein, be construed harmoniously wherever possible in order to carry out the full intent and purposes of the WCTID with respect to this project. But if there is a conflict or inconsistency between any provisions(s) of the ODOT specifications or references to the Ohio Revised Code and those contained herein, the provisions(s) granting rights, remedies, discretion and/or latitude to the WCTID, or imposing the greater duty, standard, responsibility and/or obligation on the Contractor shall govern.

SECTION 200 THE WCTID

- 200.1** The WCTID is the Warren County Transportation Improvement District, 210 W Main Street, Lebanon, Ohio 45036, and is referred to throughout the Contract Documents as if singular in number.

200.2 The WCTID is exempt from State sales tax. Contractors shall provide Exemption Certificate to the WCTID for signature as required. Each Contractor and subcontractor must procure Vendor's License as required by law. Warren County is exempt from payment of Federal Excise Tax, Transportation Tax and Ohio State Tax. Prices shall not include these taxes.

SECTION 300 ENGINEER

300.1 The term "Engineer" shall be taken to mean the Warren County Engineer.

300.2 The term SHA (State Highway Agency) referred to in Section IV, Federal and State Requirements shall be taken to mean the Warren County Engineer.

SECTION 400 SUBMISSION OF BID PROPOSALS

400.1 Bids shall be submitted in a sealed envelope marked accordingly with item(s) bid on and name of bidder, and delivered in compliance with the Legal Notice. Any improperly marked bid will not be considered.

400.2 Bidders must be on The Ohio Department of Transportation's Prequalified Contractors List. In addition, bidders must be prequalified for the necessary work types to complete the project.

400.3 All bids must comply with the specifications attached hereto. Alternative bids may be considered only if clearly marked as such with an explanation as to how the item is sufficient to meet required needs.

400.4 Each person bidding for a contract for the construction, demolition, alteration, repair, or reconstruction of any public improvement is required to file with its bid a bid guaranty in the form of either (1) a bond for the full amount of the bid or (2) a certified check, cashier's check or irrevocable letter of credit pursuant to Chapter 1305 of the Ohio Revised Code in an amount equal to ten (10) percent of the bid pursuant to Section 153.54 of the Ohio Revised Code. The successful bidder at the time he/she enters into the contract shall be required to file a performance bond in the full amount of the contract pursuant to Section 153.54(c) of the Ohio Revised Code. In lieu of a Performance Bond, bidder may submit a Combined Bid Guaranty and Contract Bond in conformance with Ohio Revised Code Section 153.571 with the proposal. Each bond must be accompanied by an effectively dated Power of Attorney which authorizes the agent to sign on behalf of the surety.

Attention Bidders: Letters of credit and bid bonds must be filed with original signatures. Facsimile and electronic copies of the letter of credit, bid bond and Power of Attorney of the Surety will be deemed non-responsive.

400.5 All bidders are required to submit the following affidavits with their bid proposal and the successful bidder will be required to enter into a written contract with the WCTID (the "Contract") within ten (10) days of the notification of the award thereof:

- (A) Non-Collusion Affidavit
- (B) Affidavit Affirming Compliance with 9.24 and 5719.042 O.R.C.
- (C) Affidavit Affirming Compliance with 3517.13 O.R.C.

These affidavits and specifications heretofore referenced shall be incorporated into and become part of the contract document. Failure to include the three (3) above-referenced affidavits will

disqualify the bid submitted for consideration. Should a bid be awarded, and the WCTID later determine that the affidavit was incorrect or falsified, the Contract shall be immediately canceled and the bidder subject to the penalties and damages, both civil and criminal, as provided by law and this Contract.

- 400.6** The WCTID reserves the right to waive any informalities, to reject any or all bids, to accept any bid which may be deemed to be for the best interest of the County and to hold such bids for a period of sixty (60) days before taking any action.
- 400.7** The Proposal forms furnished with these documents shall be completed in full; in writing in ink (or typewritten) and signed in ink. Affix the corporation seal on the proposal forms.
- 400.8** Proposals are due at the place, date, and time indicated in the Legal Notice and will be opened publicly and read aloud.
- 400.9** All prices, quantities, etc. as bid must be firm for a period of sixty (60) days from the date of the bid opening.
- 400.10** Contractor hereby agrees to defend, indemnify, and hold the WCTID, Warren County, and the Engineer, and their respective officers, trustees, commissioners, employees, members, agents, and volunteers harmless from any claims, demands or losses of any type or nature to any person, bidder or corporation arising in any manner from the Contractor's performance or failure to perform the work required under this Contract and shall pay any liabilities, judgments (including reasonable attorney's fees and litigation expenses) or losses.
- 400.11** All materials and exhibits submitted in the bid response shall become the property of WCTID and will not be returned to the bidder. All bids received constitute public information as a matter of statutory law and will be made available for public inspection and copying upon request by members of the public pursuant to the requirements of Section 149.43 of the Ohio Revised Code. Any portion of the bid that the bidder requires to be treated as confidential in nature must be marked to that effect and provided that the information falls within an appropriate exemption enumerated under Section 149.43 of the Ohio Revised Code, that portion will not be considered public record. A blanket indication of confidentiality or privilege will not be accepted and unless specific materials that fall within the appropriate statutory exemption are identified, the entire bid response will be treated as a public record.

SECTION 500 GENERAL BID SPECIFICATIONS

- 500.1** Unless otherwise specified, all material shall be new and of the best grade in its particular line and all articles shall be complete and in first class condition. All work shall be done in the best and most skilled manner, exactly as specified or detailed, and shall be subject to the approval of the Engineer and/or the WCTID. When required in the specifications, bidders shall make available for inspection a sample or similar model of the bid item prior to the award of the bid.
- 500.2** Reference to a particular trade name, manufacturer's catalog or model number for descriptive purposes is intended to guide the bidder in interpreting the requirements of the Engineer and/or the WCTID and should not be construed as excluding proposals on other types of materials, equipment and supplies. However, the bidder, if awarded a contract, will be required to furnish the particular item referred to in the specifications or description unless a departure or substitution is clearly noted and described in the bid proposal.
- 500.3** Every effort shall be made by the bidder awarded the contract to deliver items by or before the time designated in the contract. Any delinquency in such delivery without satisfactory written explanation

directed to the WCTID may result in cancellation of the contract and substitution of other goods. The defaulting bidder shall be liable for any such default, or damages, costs, or expenses arising therefrom.

- 500.4** In case of default by the bidder or Contractor, WCTID may procure the articles or service from other sources without further advertising and shall hold the Bidder or Contractor responsible for any excess costs occasioned thereby, including any reasonable expenses incurred in procuring the articles or services.

SECTION 600 INTERPRETATION OF DOCUMENTS

- 600.1** If the Bidder is in doubt as to true meaning of any part of Drawings, Specifications, or other Contract Documents, submit a written request for an interpretation therefore to the Engineer and the WCTID. The Bidder making a request will be responsible for its prompt delivery. Any interpretation of the Contract Documents will be made only by Addendum duly issued to each prospective Bidder. Neither the WCTID nor the Engineer will be responsible for explanations or interpretation of the proposed Documents except as issued in accordance therewith.
- 600.2** Addenda may be issued not later than 3 working day preceding bid due date. Questions requiring interpretation within 3 working days of bid due date will be recorded and answered during the bid negotiations preceding the signing of the contract or may result in the extension of the bid due date at the sole discretion of the WCTID.

SECTION 700 EXAMINATION OF PLANS, SPECIFICATIONS, AND SITE OF WORK

- 700.1** The Bidder is expected to examine carefully the site of the proposed work, the proposal, plans specifications, contract forms, general conditions, and addenda, before submitting a proposal. The submission of a bid shall be considered evidence that the Bidder has made such examination and is satisfied as to the conditions to be encountered in performing the work and as to the requirements of the plans, specifications, special provisions, general conditions, addenda and Contract.
- 700.2** Subject to public safety and convenience, prospective Bidders will be permitted to explore the site of the work by boring or test pits, permits for which will be issued by the Owner. Explorations shall be at the sole risk and expense to the Bidder and under conditions of maintaining and restoring safety.
- 700.3** The WCTID and the Engineer does not make any representation of soil or foundation conditions or materials, nor does it represent that drawing may not be modified to meet changes in soil conditions encountered as the work progresses. The Contractor must inspect the site of the proposed work and must assume all risk as to the nature and behavior of the material which may be encountered in excavation, whether apparent on the surface or disclosed only in the course of the work. Any geotechnical subsurface investigation or soil boring logs that may be provided by the WCTID are provided for general information only to Contractors for this project and do not change the obligations or responsibilities set forth herein. It is the sole responsibility of the Contractor to take any and all measures it feels necessary to determine the subsurface conditions prior to bidding and the nature and extent of the subsurface conditions (including variations, if any, between borings and observation locations) may not be evident until construction. In order to induce the WCTID to enter into a Contract for the work, Contractor represents that it understands its obligations hereunder and that: (a) during construction, it will be required to provide all labor, equipment, materials, and other measures to construct the improvements regardless of the subsurface conditions encountered; (b) No claims for additional costs will be considered for material, labor, equipment, or subcontractors/subconsultants to address subsurface conditions encountered during construction; and (c) costs for all related activities shall be incidental to the Project.

SECTION 800 AWARD OF CONTRACT

- 800.1** The selection of the bidder is at the sole discretion of the **ODOT PID 109613: WAR-CR21 0.23-0.4, (aka Mason-Montgomery Rd Access Management Project)**, will be awarded as soon as practicable, after opening of bids.
- 800.2** In determining the Bidder, the WCTID will consider, but not be limited to, the following criteria in addition to the Bid Amount:
- A. Bidder involved maintains permanent place of business.
 - B. Bidder has adequate equipment and facilities to perform work properly and expeditiously.
 - C. Bidder has suitable financial status to meet obligations incident to work.
 - D. Bidder has appropriate technical experience.
 - E. Bidder can complete work in timely and expeditious manner.
- 800.3** When analyzing the bids submitted, superior design, technology, workmanship, materials, size of component parts, operating costs, warranty, service facility etc. will be considered in addition to the price of the bid. It is WCTID's intent to accept the bid for which a thorough analysis of the bids submitted, proves to be the most suitable for the intended use. WCTID will consider awarding the Contract to the best, most responsive and responsible bidder, as solely determined by WCTID to be in the best interest of the Project and WCTID, but reserves the right to reject any or all bids.
- 800.4** The WCTID further reserves the right to conduct such investigations and meetings as it deems necessary after receipt of bids to assist in the evaluation of any bid and to establish the responsibility, qualifications and financial ability of the Bidders, proposed sub-contractors and other persons and organizations to do the work in accordance with the Contract Documents to the WCTID's satisfaction within the prescribed time limits. In order to facilitate this investigation, the most responsive and responsible bidder may be required to complete a Bidders Qualification Questionnaire.

SECTION III

General Provisions

GENERAL PROVISIONS

**PID 109613: WAR CR15 3.49 COLUMBIA ROAD RELCATION
(aka Mason-Montgomery Rd Access Management Project)
DEERFIELD TWP
WARREN COUNTY, OHIO**

The Specifications, General Instructions, General Provisions and Special Provisions contained herein are Contract Documents, together with, the State of Ohio, Department of Transportation, Construction and Material Specifications incorporated in the Contract and not specifically excluded, and are to be read in conjunction with said ODOT Specifications. It is intended that the Specifications, General Instructions, General Provisions and Special Provisions governing this project (and any bidding requirements and conditions) and any ODOT specifications or references to the Ohio Revised Code as set forth herein, and any attachments(s) or documents incorporated by reference herein, be construed harmoniously wherever possible in order to carry out the full intent and purposes of the WCTID with respect to this project. But if there is a conflict or inconsistency between any provisions(s) of the ODOT specifications or references to the Ohio Revised Code and those contained herein, the provisions(s) granting greater rights, remedies, discretion and/or latitude to the WCTID, or imposing the greater duty, standard, responsibility and/or obligation on the Contractor shall govern.

SECTION 100 DEFINITIONS

- 100.1 WCTID** - Whenever the word "WCTID" is used, it shall be held to mean the Warren County Transportation Improvement District, Warren County, Ohio. The word "WCTID" shall also be substituted for the words "Director" or "Department" as specified in the State of Ohio, Department of Transportation, Construction and Materials Specifications. The word "WCTID" shall also mean "Owner."
- 100.2 Engineer** - Whenever the word "Engineer" is used, it shall be held to mean the County Engineer of Warren County, the Engineer's Deputy, Project Supervisor, or Inspectors delegated by the Engineer to supervise or inspect the work. The same interpretation shall apply to the word 'engineer' as used in the State of Ohio, Department of Transportation, Construction and Materials Specifications.
- 100.3 Bidder** - An individual, firm, or corporation submitting a bid for the advertised work, acting directly or through the duly authorized representative, and qualified as provided in the Ohio Revised Code.
- 100.4 County** - Shall, at all times, mean Warren County, Ohio.
- 100.5 Estimates** - Payments to the Contractor for work, labor, or materials whether partial or final payment.

SECTION 200 PROVISIONS AND PROPOSALS

- 200.1 Plans** - The official plans, profiles, typical cross-sections, general cross-sections, working drawings and supplemental drawings, or exact reproductions thereof, approved by the WCTID which show the location, character, dimensions and detail of the work to be done, and which are to be considered as a part of the contract supplementary to these specifications.
- 200.2 Special Provisions** - Specific clauses included hereafter setting forth conditions or requirements peculiar to the project under consideration and covering work or materials involved in the proposal and estimate but not satisfactorily covered by the general specifications. **Note: All Special Provisions (Technical Specifications) can be found on the corresponding Construction Drawings included as part of this bid package.**
- 200.3 Supplemental Agreements** - Written agreements executed by the WCTID covering alterations necessary to the project as herein after provided.

- 200.4 Delivery of Proposal** - The proposals for each project shall be placed together with the proposal guaranty, in a sealed envelope so marked as to indicate the identity of the project and the name and address of the bidder. If forwarded by mail, said envelope shall then be placed in another envelope which shall be sealed and addressed as indicated in the "Notice to Contractors." The proposal will be received until the hour and date set for the opening thereof and must be in the hands of the WCTID by such time. Proposals received after the time set for receiving bids and/or opening bids shall be returned to the bidder unopened.
- 200.5 Proposal Guaranty** - Each Bidder is required to submit with its proposal a Bid Guaranty and Contract Bond in accordance with Section 153.571 of the Ohio Revised Code which specifies that each proposal must be accompanied by a bond in the sum of one-hundred (100) percent (%) of the amount bid or a certified check, cashier's check or irrevocable letter of credit in the sum of ten (10) percent (%) of the amount bid as a guarantee that, if the proposal is accepted, a contract shall be entered into. If a check is filed, it shall be made payable to The Warren County Transportation Improvement District. If a surety bond is posted, it shall be made out to the Warren County Transportation Improvement District and the State of Ohio, Department of Transportation.
- 200.6 Proposal Withdrawal** - A bidder may withdraw its proposal, provided the request in writing is in the hands of the WCTID before the time set for opening proposals. When such proposal is withdrawn it will be returned to the bidder unopened.
- 200.7 Public Opening of Proposals** - Proposals will be opened and read publicly at the time and place designated by the WCTID. Bidders, their authorized agents, and the public are invited.
- 200.8 Consideration of Proposals** - After the proposals are opened and read, they will be compared on the basis, if a unit price proposal, of the summation of the products of the approximate quantities shown in the proposal by the unit bid prices. In event of a discrepancy between unit bid prices and extensions thereof, the unit price bid shall govern. In the event lump sum items are included in the proposal, the final correct total of the proposal, after all unit price corrections are made, if any, shall govern. The WCTID will consider all properly submitted proposals, reserves the right to reject any and all bids, and if a Contract is awarded, may award it to the most responsive and responsible bidder.
- 200.9 Disqualification of Bidders** - Not more than one proposal from an individual, a firm or partnership, a corporation or an association under the same or different names, will be considered for one project. Reasonable ground for believing that any bidder is interested in more than one proposal for the work contemplated shall cause the rejection of all proposals in which the bidder is interested. The bidder shall make a non-collusion affidavit, which is properly executed and part of the proposal. Proposals in which the prices obviously are unbalanced may be rejected. Contracts will be awarded only to responsible bidders capable of performing the class of work contemplated. The WCTID reserves the right to reject any or all bids.
- 200.10 Materials and Workmanship** - Any additional items required, including labor, equipment, and/or materials, but not listed as a separate pay item in the proposal, shall be furnished, installed, removed etc. as incidental to the contract, except where noted on the plans and in the specifications.
- 200.11 No Waiver of Legal Rights** - Neither the inspection by the WCTID and/or Engineer or by any of their duly authorized agents, nor any order, measurement, or certificate by the Engineer, or said agents, nor any order by the WCTID and/or Engineer for the payment of money, nor any payment for, nor acceptance of, any work by the WCTID and/or Engineer, nor any extension of time, nor any possession taken by the WCTID or its duly authorized agents, shall operate as a waiver of any provision of this contract, or of any power herein reserved to the WCTID, or any right to damages herein provided; nor shall any waiver of any breach of this contract or failure to comply with any notice or other provision of the contract be held to be a waiver of any other or subsequent breach or failure by Contractor.

200.12 Laws to be Observed - The Contractor warrants that it is familiar with and agrees at all times to comply with the provisions of all Federal and State laws and ordinances and regulations of all political subdivisions, of the Workman's Compensation Laws, ordinances and regulations in any manner affecting the conduct of the work and it shall defend, indemnify, and save harmless Warren County, Ohio and its representatives against any claims arising from the violation of any such law, ordinance or regulation, either by the Contractor or its agents, servants or employees or the negligence of such Contractor, agent, servant or employee.

200.13 Home Office Overhead Calculations – ODOT Specification 109.05.D.2.f is specifically excluded from incorporation into the Contract. In the event of a compensable delay for which Contractor seeks to recover its unabsorbed Home Office Overhead expenses, Contractor and the WCTID agree that the HOOP formula is not an appropriate or accurate measurement of such damages under the Contract and that the Eichleay Formula is the sole measure of such allowable damages provided that Contractor can prove entitlement to such damages under the Eichleay formula as applied by the Courts of Ohio.

SECTION 300 CONTRACTS

300.1 Requirements of Contract Performance Bond – Provided that the successful Bidder has not previously submitted a combined Bid Guaranty and Contract Bond with the Bid Proposal, the successful bidder must, within ten (10) days after the award to him, and before entering into contract, furnish a bond in form consistent with the requirements of Section 153.54 and related sections of the Ohio Revised Code, to the approval of, and of the form prescribed by the WCTID, in an amount equal to one-hundred (100) percent (%) of the full amount of the bid. Said Performance Bond shall have a date of validity until "final payment" is deposited with the Contractor or until a later date as required.

300.2 Execution of Contract - The Contract shall be signed by the successful Bidder and returned, together with the performance bond, if applicable, within ten (10) days after the bidder has received notice that the Contract has been awarded. No proposal shall be considered binding upon the WCTID until the execution of the Contract and performance bond.

300.3 Failure to Execute Contract - Failure to execute and file an acceptable performance bond, if applicable, and as provided herein within ten (10) days from date of award shall be just cause for the annulment of the award and the forfeiture of the bid guaranty to WCTID, not as a penalty, but as liquidated damages. Award may then be made to the next best, most responsive and responsible bidder, as solely determined by the WCTID, or the work may be re-advertised, as determined by the WCTID. Said forfeiture shall be guided by the provisions of Section 153.54 of the Ohio Revised Code.

300.4 Lump Sum Contract - If the work is let on the basis of a lump sum contract, the estimated quantities of work are only approximate, although the result of calculations, and the bidder must obtain and be responsible for the data upon which it based its bid. It shall not be entitled to any additional compensation in case the quantities of work actually done to fulfill the contract and complete the project are greater than said estimate quantities, and assumes all risks for any mistakes in calculations.

300.5 Specifications Governing This Project - The terms and conditions of the Contract Documents will govern this Project, including but not limited to these general provisions, provisions set forth in any proposal notes, and the 2019 "ODOT Specifications" (the State of Ohio Department of Transportation Construction and Materials Specifications effective January 1, 2019 its revisions and supplements) that are incorporated herein (and not excluded). WCTID will be substituted where the specification refers to the Director. Notwithstanding the foregoing, the following ODOT Specifications are specifically excluded from this Contract:

300.5.1 Excluded ODOT Specifications:

Section 102.01, 102.03, 102.06, 102.09, 102.10, 102.11, 102.13, 102.14, 103.01, 103.02, 103.04, 103.06, 103.07, 104.02, 105.05, 105.13, 107.04, 107.13, 108.01, 108.02 (A),

108.02(G), 108.08, 108.09, 109.05(D), 109.06, 109.09, 109.10, 109.12 (A) 109.12 (B), 109.12 (C), 109.12 (D), 109.12 (E), 401.20.

300.5.2 Interpretation/Precedence - It is intended that the specifications governing this project (and any bidding requirements and conditions) and any ODOT Specifications or references to the Ohio Revised code as set forth herein, and any attachment(s) or documents incorporated by reference herein, be construed harmoniously wherever possible in order to carry out the full intent and purposes of the WCTID with respect to this project. But if there is a conflict or inconsistency between any provision(s) of the ODOT Specifications or references to the Ohio Revised Code and those contained herein, the provision(s) granting greater rights or remedies to the WCTID, or imposing the greater duty, standard, responsibility or obligation on the Contractor shall govern.

300.6 Entire Agreement. The Contract Documents contain the entire agreement between Contractor and WCTID, and no oral statements or prior written matter not specifically incorporated therein shall be of any force or effect. The Contract may not be modified except by a written document executed by both parties thereto.

SECTION 400 WCTID and ENGINEER, WORK, AND PLANS

400.1 Authority of Engineer - The Engineer, in consultation with the WCTID: (a) has immediate charge of the engineering details of each construction project; (b) is responsible for the administration and satisfactory completion of the project; and (c) has the authority to reject defective material and to suspend any work that is being improperly performed.

400.2 Errors and Omissions - The Right is reserved by the WCTID, in consultation with the Engineer, to correct by change order any errors or omissions in said plans or specifications wherever such correction is necessary for the proper fulfillment of the intention of the plans or specifications.

400.3 Interpretation of Estimates - The quantities listed in the Bid Proposal form(s) are to be considered as approximate and are to be used for the comparison of bids only. The unit prices to be tendered by the bidder are to be tendered expressly for the scheduled quantities which later may be increased or decreased within the restricting limits herein after stipulated. Where there is a conflict between the unit price and the extension thereof made by the bidder, the unit price shall govern and the WCTID and/or Engineer shall be authorized to make a correct extension of such unit bid price and to use such corrected extension in comparing bids.

400.4 Pre-Construction Meeting - After the award of the contract and before beginning any work, the Contractor and its superintendent, shall meet with the Engineer for a pre-construction meeting, to review all restrictions and regulations governing the work. Any schedules, requests, papers, approvals, submittals, changes, etc. as called for in the Contract Documents shall be made at this time unless otherwise directed.

400.5 Use of Premises - The Contractor shall confine its equipment, tools, the storing of materials, and the operation of its workmen within the right-of-way and/or work limits as approved by the Engineer. It is emphasized that damage to vegetation, especially trees, shall be held to an absolute minimum.

400.6 Dust, Water Pollution, and Erosion Control - The Contractor shall be responsible for complying with the Water Management and Sediment Control Regulations of Warren County that are in effect at the date of letting. The Contractor shall employ measures to prevent or control spills of fuels or lubricants from entering the waters of the state and submit a contingency plan to the Engineer to be effective in the event of a spill. Dust shall be kept to a minimum.

400.7 Coordination of Plans, Specifications, and Special Provisions - The specifications, plans, special provisions, and all supplementary documents are essential parts of the contract and a requirement appearing in one is as binding as though in all. They are intended to be cooperative, to describe and provide for a complete work. In case of a discrepancy, figured dimensions shall

govern over scaled dimensions and special provisions shall govern over both specifications and plans.

SECTION 500 PROGRESS OF WORK AND QUANTITIES

500.1 Extra Work - Unforeseen or other work made necessary by minor alterations of the plans, or necessary to complete the proposed improvement contract, shall be deemed extra and shall be performed by the Contractor in accordance with the specifications and as directed; provided, however, that before any extra work is started the Contractor has been authorized by the Engineer in writing to do the work. When the nature of the work required is such that the exact amount of work to be done cannot be determined precisely, the Contractor shall proceed only when authorized to do so by the Engineer.

500.2 Incidental Work at Contractor's Expense - All work done by the Contractor, specified or mentioned in the plans or specifications, as well as any minor details of work not specifically mentioned but obviously necessary for the proper completion of the work, shall be considered as incidental, and as being part of any included in the Contract. The Contractor will not be entitled to any extra or additional compensation for the same.

500.3 Increased or Decreased Quantities - The WCTID reserves the right to make such alterations in the plans or in the quantities of the work as may be considered necessary or desirable, and no conditions or provisions of the contract shall be ordered in writing and that equitable adjustment of compensation shall be agreed upon; provided further that before the work is started on any such alteration at the opinion of the WCTID a Supplemental Agreement setting forth the adjustment shall be executed by the WCTID and the Contractor. The Contractor shall perform the work as increased or decreased and compensation for materials shall be adjusted per unit price bid.

500.3.1 All change orders shall be in writing. The WCTID shall not pay any increase in expense, and Contractor agrees that it waives all right to payment for extras or otherwise valid claims for extras or change order work performed without first (a) complying with the notice provisions set forth below and (b) obtaining a prior approved change order.

500.3.2 Unit Prices for Remediation of hazardous materials. Contractor acknowledges that work for the WCTID under this Contract may involve the risk of encountering petroleum contaminated soils (PCS) or other hazardous materials during construction excavation and other work... Contractor agrees and represents that the nature of the Contract Work is such that any soil borings or similar analysis by WCTID or its Engineer or consultants may not indicate the complete and full amount of contaminated soils and that Contractor may encounter more extensive or additional PCS or other hazardous materials contamination during construction excavation than indicated in any soil borings or other tests. Contractor represents that its unit price bid for any remediation work involving hazardous materials includes all costs and considerations arising out of or relating to the work involved, including the cost of schedule impacts as a whole, all delay-related costs (including but not limited to extended home office overhead, extended field conditions, extended site conditions, labor) and all costs to excavate, store, test, transport, and dispose of contaminated materials. The original Contract unit price shall thus cover all expenses and impacts associated with remediation and handling of both the contaminated soils identified in any environmental studies plus those actually discovered during construction. Contractor's payment for any required remediation work thus shall be at the original Contract unit price for the agreed quantities of the work in question and shall constitute full and final reimbursement of Contractor for the work and settlement of all claims arising out of or pertaining to the work regardless of whether the Contract items vary in any respect from the estimated quantities. Notwithstanding the foregoing, WCTID has sole discretion to determine that an original Contract unit price would not be fair to WCTID or result in a windfall to Contractor, and may by notice to Contractor enter into negotiations over a reasonable price for excess contract work involving contaminated soils.

500.4 Claims and Notice - Contractor shall submit to WCTID and Engineer any requests or claims for adjustment in the Contract Price, Time, or other provisions of the Contract for changes directed by the Owner, as a result of deficiencies or discrepancies in the Contract Documents, for unforeseen causes, unanticipated site conditions, and for any other circumstance otherwise permitted by law or the Contract Documents within five (5) days of the act or occurrence giving rise to the claim and before Contractor proceeds to perform any extra work and seek a confirmation of receipt from WCTID and Engineer. Within ten days after providing such written notice, Contractor shall submit a written statement to the owner setting forth in detail: (1) the nature and cause of the claim and the specific provision of this Contract which support such claim; (2) specific references to the details of the Drawings and any Specifications that are affected by the claim; and (3) an itemized and substantiated statement of the amount of the claim, or of the time extension support by such documentation as the Owner may reasonably request.

500.4.1 Failure to provide the notice and confirmation procedure within the five day period, or to comply with said written statement procedures within the ten day period, shall constitute Contractor's waiver of the right to compensation or time for the act or occurrence in question. Any increase in the Contract Price, or extension in the Contract Time resulting from such claim or change may only be effected by an authorized written Change Order signed by WCTID.

500.4.1 All change orders shall be executed on the WCTID's standard change order form. Agreement on any Change Order shall constitute a final settlement of all matters relating to the change in the Work that is the subject of the Change Order, including, but not limited to, all direct and indirect costs associated with such change, any impact such change may have on the unchanged Work, and any and all adjustments to the Contract Sum and the construction schedule.

500.5 Certification of Claims and Written Statement. All written statements (as set forth above in 500.4) and claims made by Contractor, or by any subcontractor or supplier of any tier through Contractor, shall be accompanied by a sworn and notarized certification by the designated representative of Contractor having overall responsibility for Contractor's affairs, stating: (1) the claim is made in good faith; (2) the supporting data are accurate and complete to the best of Contractor's knowledge and belief; (3) the amount requested accurately reflects the contract adjustment for which Contractor believes the WCTID is liable. For subcontractor claims Contractor may not rely on subcontractor certifications but must conduct an evaluation reasonably sufficient to certify the claim as stated above, Contractor's certification of a false or inaccurate claim will entitle WCTID to recover its costs of investigating, evaluating, and defending such including but not limited to attorney, accountant and expert fees, from Contractor and/or the individual certifying the claim. Failure to provide a full and complete Certification required at the time the claim or written statement is provided shall constitute Contractor's waiver of the right to the relief it has requested but failed to properly or timely certify.

500.6 Date of Completion - The Contractor shall have completed the work on or before the calendar date specified in the Bid Proposal. Otherwise the WCTID may proceed per Sections 500.7 and 500.8 of these Specifications. If the Contract is revised in any material respect and it is determined that said revision will cause delay in the completion of the work, the WCTID shall postpone the completion date by the number of calendar days they determine.

500.6.1 Delays for Cause. When delay occurs due to unforeseen causes beyond the control and without the fault or negligence of the Contractor, including but not restricted to Acts of God, plague, pandemic, epidemic, outbreaks of infectious disease or any other health crisis that stops or requires the stopping of work, calamities, acts of the public enemy, acts of Government, acts of the State or any political subdivision thereof, fires, floods, epidemics, strikes, except those caused by improper acts or omissions of the Contractor, extra ordinary delays in delivery of materials caused by strikes, lockouts, wrecks, freight embargoes (acts of Government), such events shall be considered "Excusable Delays" that are not the fault of the WCTID or Contractor and thus are non-compensable but for which the time of completion shall be extended in whatever amounts determined by the WCTID to be equitable, provided notice and certification has been given as required above Contractor

shall, provided it has preserved entitlement to the claim through compliance with the written notice and change order procedures herein, be entitled to an extension of the Contract Times (only) for any Excusable Delays.

500.6.1.1 A "Calamity" is construed to mean an earthquake, flood, cloud burst, cyclone, or other cataclysmic phenomenon of nature beyond the power of the Contractor to foresee or to make allowances for.

500.6.1.2 **Delays and Time Extensions when the proximate cause is the act or inaction of the WCTID.** If the Contractor is delayed in the progress of the work by causes reasonably beyond its control and through no fault of its own, and the proximate cause of the delay is the WCTID's actions or inactions (within the meaning of O.R.C. §4113.62(C)(2)) and not a delay due to the acts or omissions of others or otherwise an excusable non-compensable delay under the Contract Documents, the Contractor shall be entitled to a reasonable time extension and extended field general conditions in a reasonable amount as determined by the WCTID (which determination may be made after consultation with its Engineer, Consultant, Construction Manager, or Architect, if any). In addition, Home office overhead shall be allowable pursuant only to the Eichleay formula as applied by the Courts of Ohio and such unabsorbed home office overhead shall (a) be based on business days lost to the critical path of the Project and (B) only be allowed if the cumulative delay in question to the critical path exceeds fourteen (14) days. Contractor represents and agrees that any such extension of time, extended field general conditions, and Eichleay Damages shall be the Contractor's sole remedy and measure of "delay damages" and Contractor represents as a material inducement to WCTID to enter this Contract, that Contractor shall not be entitled to any additional compensation for any other damages allegedly arising out of or relating to the delay in question, including but not limited to, any additional fees, costs of acceleration, consequential damages, loss of efficiency, loss of productivity, lost opportunity costs, impact damages, lost profits or other similar remuneration.

500.6.2 No time extensions will be granted for any delay or suspension of the work due to fault of the Contractor.

500.6.3 Postponement of the completion date shall be immediately recorded by the appropriate journal entry by the WCTID and the Contractor formally advised. If the WCTID should suspend the work in whole or in part as provided in these specifications, the date of completion shall be extended the number of days that the suspension directly or indirectly delays completion of the work.

500.6.4 If the WCTID for any reason extends the completion date, the extension of time shall not relieve the bond annexed this agreement or the sureties thereon from any of the obligations therein expressed.

500.6.5 If the Contractor files any bankruptcy related action such as Chapter 7 or Chapter 11 or placed in receivership, the WCTID may terminate this Contract and seek alternative completion. The Contractor will be paid for work completed to date, less any damages or expenses incurred by the WCTID in re-bidding the project, awarding it elsewhere, or completing it itself.

500.7 WCTID to Complete Work In Case of Failure - If in the opinion of the WCTID, the Contractor has not commenced the work, within a reasonable time or does not carry the same forward with reasonable progress, or is improperly performing its work, or has abandoned or fails or refuses to complete the work under the provisions of these specifications and the Contract, said WCTID shall

have full power and authority to enter upon and construct said improvement or any part thereof either by Contract, force account, or in such manner as it may deem for the best interest of the public; paying in full costs and expenses thereof from the balance of the Contract price unpaid to the Contractor. In case there is insufficient balance to pay for the work, the WCTID shall require the Contractor, or the surety on its bond, to pay the cost of completing the work.

500.7.1 The WCTID shall withhold estimates, or partial estimates, that may be due the Contractor for work performed to date, until it has fulfilled all the provisions mentioned above the extension of time.

500.7.2 If the conditions beyond the control of the WCTID or Contractor prevent the completion of the project, such as (but not limited to) changes in the law, EPA regulations, catastrophe or court order, then the WCTID may, in its discretion, pro-rate and cancel the project. Any materials purchased but not utilized shall be paid for by and become property of the WCTID.

500.8 Failure to Complete by Specified Date - Time is of the essence of this Contract. The parties hereto acknowledge that the WCTID is entitled to full use of the completed Work, or any portion thereof as applicable to any interim completion dates or milestones, following expiration of the Contract Time and that if the Contractor fails to complete the Contract or any portion thereof on or before the completion date the WCTID will sustain extensive damage and serious loss as a result. The exact amount of such damages will be extremely difficult to establish and calculate with certainty. Thus, the WCTID and Contractor agree that if the Contractor fails to complete the Work or any portion thereof before the date agreed upon as mentioned elsewhere in the Contract, the WCTID shall be entitled to retain or recover from the Contractor, as liquidated damages and not as a penalty, the per diem amounts set forth in the 2019 ODOT CMS Table 108.07-1 SCHEDULE OF LIQUIDATED DAMAGES (the "2019 ODOT CMS Schedule of Liquidated Damages"), commencing upon the first day following expiration of the Contract Time and continuing until the actual Date of Substantial Completion:\$400.00 Contractor and the WCTID agree that such liquidated damages are a reasonable pre-estimate of damages the WCTID will incur because of delayed completion of the Work. If the above per diem figure is left blank, Contractor agrees that a fair and reasonable alternate estimate of the damages WCTID will incur because of delayed completion of the Work ,or any portion thereof, and thus the liquidated damages that shall be paid is that set forth in Table 108.07-1 of the 2019 ODOT CMS Schedule of Liquidated Damages. Permitting the Contractor to continue and complete the Work or any part of the Work after the Completion Date, or after extensions to the Completion Date, is without prejudice to and will not waive any of the rights of the Department under the Contract.

500.8.1 The WCTID may deduct liquidated damages described above from any unpaid amounts then or thereafter-due Contractor under the Contract. Any liquidated damages not so deducted from any unpaid amounts due the Contractor shall be payable to the WCTID upon demand.

500.8.2 The liquidated damages set forth herein shall be WCTID's exclusive damage remedy for Contractor's failure to complete the Work on or before the date of Substantial Completion, but such liquidated damages shall in no way limit Owner's entitlement to damages for any other injury, damage, or loss, other than for delay, for which Contractor may be responsible pursuant to the terms of this Agreement or applicable law.

500.9 Suspension of Work - For such a period as is necessary or during such time the weather is unsuitable for proceeding with the work, the WCTID may suspend work, at places or altogether, if in its opinion, public need requires it. In case of such suspension during a working season, the time within which the Contractor is required to complete the work shall be extended by as many days as the same was suspended. Upon any stoppage of the work, all material shall be safely placed, so as to not obstruct or impede travel on the right-of-way.

500.10 Order and Progress of Work - The work under this contract shall be prosecuted at as many different places, at such times in such sections along the improvement and with such forces as the

Engineer may direct. Completed portions of the roadway shall be opened to travel as directed by the Engineer, but shall not be construed as an acceptance of the work done. Should the work, for any reason, be discontinued by the Contractor, it shall, before again commencing the work, give the Engineer notice of its intention at least twenty-four (24) hours in advance of commencement.

500.11 When Estimates May Be Withheld - Estimates may at any time be withheld or reduced if, in the opinion of the WCTID, the work is not proceeding in accordance with the provisions of this contract; or if the work is not progressing in proportion to the time spent working; or if the estimate is not in the same proportion to the entire contract price as the amount of the work completed is to the entire work.

500.12 Violations - At no time during the execution of this Contract shall the Contractor or any subcontractor violate any Federal, State, Municipal, Township, or local laws, statutes, regulations, ordinances, or resolutions.

500.13 Injunctions - If legal obstruction to the completion of the work arises, and if the legal obstruction will cause delay in the completion of the work, the WCTID may postpone the completion date by the number of calendar days they determine.

500.14 Coordination Responsibilities. Contractor shall be responsible to coordinate with any utility or railroad company (or entities) responsible for any necessary utility relocation, railroad coordination, electrical service installation or any similar services required during the construction to complete the construction within the Contract Times. Any Contractor costs for such shall be incorporated into the line item and/or profit and overhead markups incorporated into the Contract and the time for same shall be considered incorporated into Contractor's obligation to complete within the Contract Times. The WCTID will assist Contractor in obtaining such coordination, but such assistance shall not relieve the Contractor of its obligations hereunder. The WCTID will coordinate with and obtain approval by ODOT and/or the Engineer, as may be appropriate or required, for any necessary traffic signal or roadway design elements of the construction. Contractor shall be responsible to coordinate any inspections or approvals necessary to be obtained from ODOT and/or the Engineer, as may be appropriate or required, for the Work during construction.

SECTION 600 CONTRACTOR INSURANCE REQUIREMENTS

The following types of insurance coverages and limits are required and shall be written for not less than the following, or greater if required by law and/or as otherwise specifically provided in the Contract or required by the WCTID as listed below. The WCTID, WCEO, Warren County, the Township and their respective trustees, commissioners, officers, agents and employees are to be named as additional insureds with all rights under those policies unless otherwise determined by the WCTID.

600.1 Workmen's Compensation and Employers Liability as required by the laws of the State of Ohio.

600.2 The Contractor shall not commence work under the Contract until it has obtained all the insurance required hereunder and has submitted, in quadruplicate, an appropriate Declaration of Insurance, as evidence of coverage which has been approved by the WCTID and concurred by the Engineer. The Contractor shall not allow any Subcontractor to commence work on its subcontract until all similar insurance required by the Subcontractor has been so obtained and approved. Approval of the insurance by the WCTID shall not relieve or decrease the liability of the Contractor hereunder.

600.3 Contractor's Liability Insurance

600.3.1 The Contractor shall acquire and maintain during the term of the Contract Bodily Injury and Property Damage Liability Insurance under a standard Comprehensive General/Automobile Liability Policy which shall provide and include coverage on all Contractor's Operations,

Protective (Sublet) Liability, Contractual Liability, Completed Operations Liability, Owned Automobiles and Non-Owned and Hired Automobiles.

600.3.2 Coverage for an "if any" basis: Property Damage Liability Insurance shall be provided on any demolition, blasting, excavating, shoring or similar operation on an "if any" basis.

600.3.3 Bodily Injury Liability limits shall be for an amount of no less than One-Million **(\$1,000,000.00)** Dollars for injuries, including wrongful death to any one person and subject to the same limit for each person, in an amount of not less than One-Million **(\$1,000,000.00)** Dollars on the account of any one occurrence.

600.3.4 Property Damage Liability Insurance in an amount of not less than One-Million **(\$1,000,000.00)** Dollars per occurrence with General Liability extended to provide "Broad Form Property Damage Liability" and in an amount of not less than **Two-Million Five-Hundred Thousand (\$2,500,000.00) Dollars aggregate** for damage on account of all occurrences.

600.3.5 Any combination of underlying Comprehensive General/Automobile Liability coverage with Umbrella/Excess Liability coverage which provides **no less than Two-Million Five-Hundred Thousand (\$2,500,000.00) Dollars** Single Limit Bodily Injury & Property Damage Liability Insurance for the Contractor will also be acceptable.

600.4 Contractor's Risk and/or Installation Floater Insurance - Each Contractor shall maintain insurance to protect the Project, the Work, and/or the WCTID, WCEO, Warren County, and the Engineer, and their respective officers, trustees, commissioners, employees, members, agents, and volunteers from loss incurred by fire, lightning, extended coverage hazards, vandalism, theft, explosion, and malicious mischief in the full amount of the Contract and such insurance shall cover all labor and materials connected with the work, including materials delivered to the site but not yet installed. The Contractor may obtain this insurance either through a standard Builder's Risk policy or Installation Floater Coverage sufficient to cover the above risks as they pertain to the Project.

600.5 The Policies as listed in the paragraphs 600.1 through 600.4 shall all contain the following special provisions:

* *The Contractor agrees that written notice will be mailed to the WCTID thirty (30) days prior to cancellation or reduction of the insurance afforded by this policy with respect to the Contract involved.*

* *The Contractor shall submit evidence of such insurance to the WCTID with the executed contract in the form of a Certificate of Insurance, naming the Warren County Transportation Improvement District as the Certificate holder.*

600.5.1 The maintaining of such insurance as outlined herein shall in no way constitute a waiver of legal liability for damage to an adjoining property or their contents or the work of others.

600.5.2 Should any liability arise as a result of the action of the Contractor, its subcontractors or suppliers, or employees for which there is insufficient insurance coverage, the Contractor agrees to indemnify, defend, and hold the WCTID, WCEO, Warren County, and the Engineer, and their respective officers, trustees, commissioners, employees, members, agents, and volunteers harmless from any liability or judgment (including reasonable attorney's fees and litigation expenses) and losses. Nothing in the Contract Documents and insurance requirements is intended to create in the public or any member thereof a third party beneficiary hereunder, nor is any term and condition or other provision of the Contract intended to establish a standard of care owed to the public or any member thereof.

SECTION 700 PAYMENTS, RETAINAGE, AND FINALITIES

- 700.1 Payroll Records** - Payroll records kept in accordance with Section 4115.07, of the Ohio Revised Code and shall be open to inspection of authorized representatives or officials of WCTID. The contractor shall furnish the WCTID with an affidavit every thirty (30) days during the construction period stating that all employees and sub-contractors performing services on this project have been paid the prevailing rate of wages as certified by the Department of Industrial Relations provided by Chapter 4115 of the Revised Code of the State of Ohio.
- 700.1.1** The Contractor furnish upon the request of the WCTID prior to any partial payment(s) an affidavit IAW O.R.C. 1311 (Mechanics Liens) listing money owed or paid to all subcontractors, laborers, or materialmen, and the WCTID, upon receipt of said affidavit, may, in its discretion, disburse appropriate sums owing as indicated directly to subcontractor's, materialmen, and laborers, with the balance being remitted to the Contractor.
- 700.2 Retainage** - Partial payments to the Contractor for labor performed under either a unit price or lump sum price contract shall be made at the rate of ninety-two (92) percent of the estimates prepared by the Contractor and approved by the Engineer. All labor performed after the project is fifty (50) percent complete shall be paid for at the rate of one-hundred (100) percent of the estimates submitted by the Contractor and approved by the Engineer. The aforementioned requirements are pursuant to Section 153.13 of the Ohio Revised Code.
- 700.2.1** From the date the contract is fifty (50) percent complete, as evidenced by payments in the amount of at least fifty (50) percent of the contract to the person(s) with whom the WCTID has contracted, except in the case of contracts the total cost of which is less than fifteen thousand (\$15,000) dollars, all funds retained pursuant to Sections 153.12 and 153.14 of the Ohio Revised Code for the faithful performance of work shall be deposited in the escrow account designated in Section 153.63 of the Ohio Revised Code. After the contract is fifty (50) percent complete, no further funds shall be required.
- 700.3 Final Cleaning Up** - Upon completion of the work and before acceptance and final payments shall be made, the Contractor shall clean the roadway, borrow pits, stream channels and banks within the right-of-way at drainage structures, and all ground occupied by the Contractor in connection with the work, of all rubbish, excess materials, false work, temporary structures and equipment, and all parts of the work shall be left in a neat and presentable condition satisfactory to the Engineer. All land on which a temporary easement existed shall be returned to its preconstruction condition by the Contractor, the expense of which is included in the amount of this contract.
- 700.4 Final Inspection** - Wherever the work provided and contemplated by the Contractor has been satisfactorily completed and the final cleaning up performed, the Engineer shall, within ten (10) days, unless otherwise provided, make the final inspection.
- 700.5 Final Payments** - The Engineer shall, as soon as possible after the completion of the entire work, certify such completion to the WCTID, and the WCTID shall pay the entire sum so found to be due hereunder, after deducting there from all previous payments and all amounts to be kept and all amounts to be retained, under the provisions of this contract. All prior partial estimates and payments shall be subject to correction in the full settlement.
- 700.6 Payment of Total Costs to be Final Settlement of all Claims of the Contractor** - The WCTID shall pay, and the Contractor shall receive, the sum herein stipulated as full compensation for everything furnished and done by the Contractor under this contract, including all incidental work required but not specifically mentioned, and also for all loss or damage arising out of the nature of the work aforesaid, or from the action of the weather, or from any unforeseen obstruction or difficulty encountered in the prosecution of the work, and for all risks of any description connected with the work, and for all expenses incurred by or in consequence of the suspension or discontinuance of the work, as herein specified, and for well and faithfully completing the work, and whole thereof, as herein provided, together with remedying all defects developing during the period for which the work is guaranteed. Final payment by the WCTID does not release the Contractor for

any defects in construction, workmanship, or materials which could not have been ascertained by reasonable inspection.

700.7 Last Payment to be Final - Before the final estimate is allowed, the WCTID will require the Contractor to submit an affidavit showing that all claims and obligations arising in connection with the performance of the contract to include, but limited to, money owing to subcontractors, materialmen, or laborers have been satisfactorily settled. This requirement also includes an affidavit from any sub-contractor(s) employed on the project. The acceptance by the Contractor of the last payment as aforesaid shall operate as and shall be a release by the Contractor to the WCTID and agents thereof for all claims and liability to the Contractor for anything done or furnished for, or relating to the work, or for any act or neglect of the WCTID, or of any person relating to or affecting the work except for any pending or asserted claims that have been properly preserved in accordance with the Contract requirements by written notice to WCTID, and which remain unresolved at the time of final payment. .

700.8 Construction Funds Held in Trust. Contractor agrees that all funds it receives from WCTID for the performance of this Contract shall be held in trust by Contractor for the benefit of all its Subcontractors, suppliers, laborers, and materialmen, and Contractor shall not itself have any interest in such funds until all these obligations have been satisfied in full. Contractor further agrees that any funds received shall be used exclusively for the prosecution of the Project Work, and none will be diverted to satisfy other obligations of Contractor. WCTID does not have an obligation to pay or see to the payment of money to any subcontractor or supplier.

SECTION 800 CLOSE-OUT PROCEDURE

800.1 When the Engineer and a Contractor determine the Work or a designated portion thereof is complete and acceptable in accordance with the Contract Documents, the Contractor shall submit a letter so stating to the Engineer, with a list of all incomplete items of Work and anticipated dates of completion for each.

800.2 Upon receipt of the letter claiming Substantial Completion, the Engineer will conduct an inspection. A list of items requiring completion or correction will be issued. If the Engineer approves the Contractor's claim of Substantial Completion, the Contractor will prepare a "Certificate of Substantial Completion" for acceptance by the WCTID and the Engineer. This Certificate will establish the Date of Substantial Completion.

800.3 When the Contractor has completed all items of work on the "Completion and Corrections List" and is satisfied that all work required by the Plans and Specifications for its contract work has been completed, it shall submit its Final "Application for Payment" for all funds due and/or the retained percentage to the Engineer along with the following items:

800.3.1 "Final Certification of Contractor" and "Consent of Surety" form.

800.3.2 Affidavits as required by the Contract if required by the WCTID.

800.3.3 Copies of test reports as may be required.

800.3.4 Record Drawings or information as required by the Contract Documents for Record Drawings.

800.3.5 Operating and Maintenance Instructions or Manuals required by the Contract Documents.

800.3.6 Other data as required by governing bodies.

800.3.7 Other submittals as required by the Technical Specifications such as Specific Guaranties, Warranties, Certificates, etc.

- 800.4** Upon receipt of the Contractor's Final Application and other required material, the Engineer shall verify its completeness and/or correctness. Incomplete or incorrect items shall be returned to the Contractor for corrections and resubmitted.
- 800.5** When the Engineer can certify that all Work under the Contract is complete and the Contractor has submitted all required items, it shall include the Contractor's Final Application on the "Final Certificate for Payment" and submit it to the WCTID.
- 800.6** The Engineer shall approve the "Final Certificate for Payment"; execute and forward three (3) copies to the WCTID. Any Contract or Contractor not receiving Engineer approval shall be deleted from the "Final Certificate for Payment."
- 800.7** The WCTID shall approve the "Final Certificate for Payment," deleting any unacceptable Contracts or Contractors, and return two (2) executed copies to the Engineer. Final checks shall then be distributed by the WCTID as required by the Contract Documents.
- 800.8** The Bid Guaranty shall not be released until final payment is deposited by the Contractor.

SECTION 900 SAFETY

- 900.1** The Contractor will be responsible for initiating, maintaining, and supervising all safety precautions and programs in connection with the Work. It will take all necessary precautions for the safety of, and will provide the necessary protection to prevent damage, injury, or loss to all the work and all materials or equipment to be incorporated therein, whether in storage on or off the site, and other property at the site or adjacent thereto, including trees, shrubs, lawns, walks, pavements, roadways, structures, and utilities not designated for removal, relocation, or replacement in the course of construction.
- 900.2** Contractor will erect and maintain, as required by the conditions and progress of the Work, all necessary safeguards for safety protection. It will notify owners of adjacent utilities when prosecution of the work may affect them.
- 900.3** The Contractor shall maintain at its office or other well-known place at the job site, all articles necessary for giving first aid to the injured, and shall make standing arrangements for the immediate removal to a hospital or a doctor's care of persons (including employees) who may be injured at the job site. In no case shall employees be permitted to work at a job site before the employer has made a standing arrangement for removal of injured persons to a hospital or a doctor's care.
- 900.4** Lights, signs and barricades shall be used to maintain traffic and safety for vehicular and pedestrian traffic during the course of this contract in accordance with the specifications.
- 900.5** The Contractor must have a Safety & Health Management Program in place and shall submit a copy of their Program to the Warren County Engineer's Safety/Risk Manager prior to the commencement of construction. The Program shall include, but shall not be limited to, management commitment, employee involvement, periodic work site surveys, hazards prevention, and control of safety and health education training (see 29 CFR 1926.20 for reference). In addition, prior to the commencement of construction, contractor shall designate a qualified and experienced safety representative at the site, whose duties and responsibilities shall be the prevention of accidents and the maintaining of supervising and safety precautions and programs.

SECTION 1000 MISCELLANEOUS

- 1000.1 Permits.** The Contractor is responsible for obtaining and paying for all necessary permits and licenses from the proper authorities. The Contractor shall give all notices and comply with all laws, ordinances, rules, and regulations bearing on the conduct of the work as drawn and specified. If the

Contractor observes that the Contract Documents are at variance therewith, it shall promptly notify the Owner in writing.

1000.2 Course of Conduct. No course of conduct or dealing between the parties, nor express or implied acceptance of alterations or additions to the Work, and no claim that WCTID has been unjustly enriched by an alteration or addition to the Work, whether or not such unjust enrichment to the work or WCTID in fact exists, shall form the basis of any claim for an increase in the Contract Sum or any amount due under the Contract Documents, or a change in the Contract Time. Any claim by Contractor that is not made in strict compliance with the provisions of the Contract, including but not limited to sections 500.4 and 500.5 herein, is waived.

1000.3 Disputes.

1000.3.1 - All claims, disputes, or other controversies between WCTID and Contractor arising out of or relating to the Contract or the breach thereof shall be decided by litigation in the Warren County Court of Common Pleas, which shall have exclusive jurisdiction to hear and determine any such claims, disputes, or other controversies.

1000.3.2 - The Contract shall be governed by the law of the State of Ohio, without regard to principles of conflicts of laws.

1000.3.3 - Notwithstanding any claim, dispute or other controversy between WCTID and Contractor, or between Contractor and its subcontractor(s), it shall be the responsibility of Contractor to continue to prosecute all of the Work and perform all of its services diligently and in a good and workmanlike manner in conformity with the Contract.

1000.3.4 - In any litigation between WCTID and Contractor arising out of or relating to the Contract or the breach thereof, WCTID shall recover all reasonable attorney's fees and costs, court costs and fees, and expert witness fees and expenses incurred.

1000.4 Jointly Drafted - The parties acknowledge that each party and, if it so chooses, its counsel have reviewed this Contract and that the normal rule of construction to the effect that any ambiguities are to be resolved against the drafting party shall not be employed in the interpretation of this Contract and any amendments or exhibits thereto.

1000.5 Interest - Amounts due and unpaid Contractor under this Agreement shall accrue interest at the rate of two percent per annum, commencing sixty (60) days after such amounts were due.

1000.6 No third-party beneficiaries. Nothing in this Contract is intended, nor will be deemed, to confer rights or remedies upon any person or legal entity not a party to this Agreement.

1000.7 Reporting, Investigating, and Resolving Motorist Damage Claims. The Contractor is required to report, investigate, and resolve motorist damage claims according to 107.10 and 107.12 of the 2019 ODOT Specifications as follows. When a motorist reports damage to its vehicle either verbally or in writing to the Contractor, the Contractor shall within 3 days make and file a written report to the WCTID. If the WCTID directly receives a motorist's claim, it will, in its discretion, forward the claim report to the Contractor and/or the Contractor's insurance company to resolve. If the Contractor or its insurance company does not resolve the claim in a timely manner, the WCTID may advise the motorist of the option of pursuing the claim in the Ohio Courts. In the event of a lawsuit filed against the WCTID by the motorist, the WCTID, as co-insured party, may request the Contractor's insurance company to defend this lawsuit and hold the BCTID harmless according to the insurance requirements of this Contract. Any attorneys fees, court costs, litigation expenses, judgments, or settlement amount incurred by the WCTID arising out of any litigation or claims by a motorist hereunder will be assessed to the Contractor and deducted from the project, and notify Contractor of such action. If the Contract balance is insufficient to cover the extent of the backcharge,

1000.8 Severability - If any portion of this Contract is determined to be void, voidable or illegal, such portion shall be deemed severed from the other portions that are not void, voidable or illegal and (a) such other portions shall be enforceable in accordance with their terms; and (b) the severed provision shall be substituted by a valid provision which most closely approximates the intent and purpose of the severed provision and which would be enforceable to the maximum extent permitted by law.

SECTION 1100 DBE Requirement

1100.1 Disadvantaged Business (DBE) Requirement. DEB participation goals (Subcontracts, materials, supplies) have been set on this project for those certified as DBE's in accordance with the TEA-21 (1998) and 49 CFR, Part 26, and qualified to bid with ODOT under chapter 5525 of the Ohio Revised Code (O.R.C.). **DBE Goal: 5%**

SECTION 1200 Drug-Free Workplace

1200.1 Selected Contractor and each subcontractor shall be enrolled and in good standing in the Drug-Free Workplace (DFWP) Program or a similar program approved by the Bureau of Worker's Compensation.

1200.2 The Contractor shall insert in each of its subcontracts a clause requiring all subcontractors to comply with this requirement.

SECTION 1300 Warranty and Correction Period.

1300.1 Warranty - The Contractor fully warrants, for the benefit of the WCTID that all materials and equipment shall be new unless otherwise specified, of good quality, in conformance with the Contract Documents and free from defects in materials or workmanship.

1300. 2 Correction Period. In addition to the Contractor's obligations under this Section 1000.8, if, within one year after the date of substantial completion of the Work or after the date of commencement of the warranties hereunder (or such longer period of time as may be prescribed by the terms of any applicable special warranty or guarantee required by the Contract Documents), any of the Work is found not to be in accordance with the requirements of the Contract Documents, or if the repair of any damages to the land or any areas made available for Contractor's use in performing the Work is found to be defective, the Contractor shall, without cost to the WCTID, promptly correct or repair the damage, land, or defective Work after receipt of written notice from the WCTID or Engineer. If the Contractor fails to correct or take steps to correct such defective or nonconforming Work within seven (7) days after receipt of notice from the WCTID or Engineer, the WCTID may correct or repair the Work in question and all costs, claims, and damages arising out of or relating to such corrective action will be paid by Contractor to the WCTID on demand, including but not limited to, attorneys fees, and costs or charges of engineers, and other professionals, and all court or other dispute resolution costs

SECTION IV

Federal and State Requirements

**ODOT's LPA Template (ODOT Spec Book and LPA Spec Book)
Required Contract Provisions.**

1. ODOT'S 2019 CONSTRUCTION AND MATERIAL SPECIFICATIONS (C&MS) AND ITS SUPPLEMENTS

With the exception of Section 100 "General Provisions" included in the matrix below, ODOT's Construction and Material Specifications (CM&S) and its supplements are hereby incorporated by reference, in their entirety, as if rewritten herein. The incorporation of this document by reference does not interfere with the order of precedence set forth in Section 105.04 of the CMS Manual.

In accordance with the Locally Administrated Transportation Projects Manual of Procedures (LATPM), when bidding this project, the Contractor should replace the terms "the Department", "the Engineer", "the DCE" and "the DCA" with the term "the Local Public Agency (LPA)." Furthermore, nothing in this document is intended to alter the LPA's adherence to Ohio Revised Code, local ordinance or other applicable requirements which are properly established.

Excluded 2019 Specifications			
Section 102.01	Section 103.01	Section 105.19	
Section 102.03	Section 103.02	Section 107.04	
Section 102.06	Section 103.04	Section 107.13	
Section 102.09	Section 103.05	Section 108.01	
Section 102.10	Section 103.06	Section 108.02(B)	
Section 102.11	Section 103.07	Section 108.02(E)	
Section 102.13	Section 104.02(A)	Section 108.02(G)	
Section 102.14	Section 105.05	Section 108.08	
Section 102.17			

2. STEEL AND IRON PRODUCTS MADE IN THE UNITED STATES

Furnish steel and iron products that are made in the United States according to the applicable provisions of Federal regulations stated in 23 CFR 635.410 and State of Ohio laws, and ORC 153.011 and 5525.21. "United States" means the United States of America and includes all territory, continental or insular, subject to the jurisdiction of the United States. Both the State and Federal requirements contained in (A.) and (B.) of this section apply to this contract.

A. Federal Requirements. All steel or iron products incorporated permanently into the Work must be made of steel or iron produced in the United States and all subsequent manufacturing must be performed in the United States. Manufacturing is any process that modifies the chemical content; physical shape or size; or final finish of a product. Manufacturing begins with the initial melting and mixing and continues through the bending and coating stages. If a domestic product is taken out of the United States for any process, it becomes a foreign source material.

B. State Requirements. All steel products used in the Work for load-bearing structural purposes must be made from steel produced in the United States. State requirements do not apply to iron.

C. Exceptions. ODOT may grant specific written permission to use foreign steel or iron products in bridge construction and foreign iron products in any type of construction. ODOT may grant such exceptions under either of the following conditions:

1. The cost of products to be used does not exceed 0.1 percent of the total Contract cost, or \$2,500, whichever is greater. The cost is the value of the product as delivered to the project.

2. The specified products are not produced in the United States in sufficient quantity or otherwise are not reasonably available to meet the requirements of the Contract Documents. ODOT may require the Contractor to obtain letters from three different suppliers documenting the unavailability of a product from a domestic source, if the shortage is not previously established.

D. Proof of Domestic Origin. Furnish documentation to the Engineer showing the domestic origin of all steel and iron products covered by this section, before they are incorporated into the Work. Products without a traceable domestic origin will be treated as a non-domestic product.

3. CERTIFICATION AGAINST DEBARMENT AND SUSPENSION

The bidder hereby certifies by signing this proposal that, except as noted below, under penalty of perjury and under other such penalties as the laws of this state and the United States of America provide, that the company or any person associated there with in the capacity of owner, partner, director, officer, principal investigator, project director, manager, auditor, or any position involving the administration of federal funds is **not** currently under suspension, debarment, voluntary exclusion or determination of ineligibility by any federal agency; that the company or any person associated therewith in the capacity of owner, partner, director, officer, principal investigator, project director, manager, auditor, or any position involving the administration of federal funds has **not** been suspended, debarred, voluntarily excluded or determined ineligible by any federal agency within the past three (3) years; that the company or any person associated therewith in the capacity of owner, partner, director, manager, auditor, or any position involving the administration of federal funds does **not** have a proposed debarment pending; that the company or any person associated there with in the capacity of owner, partner, director, officer, principal investigator has **not** been indicted, convicted, or had a civil judgment rendered against the company, or themselves by a court of competent jurisdiction in any matter involving fraud or official misconduct within the past three (3) years.

If there are exceptions to any of the above clauses, please include a statement with the bid package detailing these exceptions.

Exceptions will not necessarily result in denial of award but will be considered in determining bidder responsibility. For any exception noted, indicate below to whom it applies, initiating agency and dates of action. Providing false information may result in criminal prosecution or administrative sanctions. Execution of this proposal on the signature portion thereof shall constitute also signature of this certification as permitted by Title 28 United States Code, Section 1746.

4. PREQUALIFICATION

Only pre-qualified contractors are eligible to submit bids for this PROJECT. Pre-qualification status must be in force **at the time of bid, at the time of award, and through the life of the construction contract.** For work types that ODOT does not pre-qualify, the LPA must still select a qualified contractor. Subcontractors are not subject to the pre-qualification requirement. The “prime” contractor must perform no less than 30 percent of the total original contract price.

5. PN033 - 4/18/2008- AS PER PLAN DESIGNATION

(Not required by FHWA, but strongly suggested if As Per Plan is used by the LPA)

For the last several years the “As Per Plan” designation has been added to some item descriptions in the proposal to assist the Contractors to easily identify standard items that have been altered by plan notes.

The “As Per Plan” designation has proven to be a very useful tool for the Contractors. However, its use was never intended to relieve the Contractors of their responsibility to read, bid and construct all items in accordance with all governing plan notes. Therefore, the absence of an “As Per Plan” designation on some item descriptions in the proposal for which there are clear and controlling plan notes does not relieve the Contractors of the responsibility to read, bid and construct those particular items in accordance with the governing plan notes.

Be advised that the item descriptions in the bidding proposal must be read or interpreted with the governing plan notes and the Construction and Material Specification Manual. A claim based upon an “order of precedence” basis will be denied. In the event that a conflict, either real or perceived, exists between the item description and the governing plan note, the Contractors are to request clarification through the pre-bid process.

6. **FEDERALLY REQUIRED EEO CERTIFICATION FORM**

The bidder hereby certifies that he **has**, **has not**, participated in a previous contract or subcontract subject to the equal opportunity clause, as required by Executive Orders 10925, 11114, or 11246, and that he **has**, **has not**, filed with the Joint Reporting Committee, the Director of the Office of Federal Contract Compliance, a Federal Government Contract Compliance, a Federal Government contracting or administering agency, or the former President's Committee on Equal Employment Opportunity, all reports due under the applicable filing requirements. **The Bidder must circle the appropriate “has or has not” above.**

7. **PN 017 - 10/15/2004 - FEDERALLY REQUIRED EEO CERTIFICATION CLAUSE**

The Federally Required EEO Certification is required by the Equal Employment Opportunity Regulations of the Secretary of Labor (41 CFR 60-1.7 (b) (1)) and must be submitted by bidders and proposed subcontractors only in connection with contracts and subcontractors which are subject to the equal opportunity clause. Contracts and subcontracts which are exempt from the equal opportunity clause are set forth in 41 CFR 60-1.5. (Generally only contracts or subcontracts of \$10,000 or under are exempt.)

Currently, Standard Form 100 (EEO-1) is the only report required by the Executive Orders or their implementing regulations.

Proposed prime contractors and subcontractors who have participated in a previous contract or subcontract subject to the Executive Orders and have not filed the required reports should note that 41 CFR 60-1.7 (b) (1) prevents the award of contracts and subcontracts unless such contractor submits a report covering the delinquent period or such other period specified by the Federal Highway Administration or by the Director, Office of Federal Contract Compliance, U.S. Department of Labor.

8. **PN 026 - 10/15/2004 - CERTIFICATION OF NONSEGREGATED FACILITIES**

(a) Certification of Nonsegregated Facilities, as required by the May 9, 1967, Order of the Secretary of Labor (32 F.R. 7439, May 19, 1967) on Elimination of Segregated Facilities (for a Federal-aid highway construction contract exceeding \$10,000 which is not exempt from the provisions of the Equal Opportunity clause).

(b) Bidders are cautioned as follows: By signing this bid, the bidder has agreed to the provisions of the “Certification of Nonsegregated Facilities” in this proposal. This certification provides that the bidder does not maintain or provide for his employees facilities which are segregated on a basis of race, creed, color, or national origin, whether such facilities are segregated by directive or on a de facto basis. The certification also provides that the bidder will not maintain such segregated facilities.

(c) Bidders receiving Federal-aid highway construction contract awards exceeding \$10,000 which are not exempt from the provisions of the Equal Opportunity clause, will be required to provide for the forwarding of the following notice to prospective subcontractors for construction contracts and material suppliers where the subcontracts or material supply agreements exceed \$10,000 and are not exempt from the provisions of the Equal Opportunity clause.

"Notice to Prospective Subcontractors and Material Suppliers of Requirement for Certification of Nonsegregated Facilities" -

- (a) A Certification of Nonsegregated Facilities as required by the May 9, 1967, Order of the Secretary of Labor (32 F.R. 7439, May 19, 1967) on Elimination of Segregated Facilities, which is included in the proposal, or attached hereto, must be submitted by each subcontractor and material supplier prior to the award of the subcontract or consummation of a material supply agreement if such subcontract or agreement exceeds \$10,000 and is not exempt from the provisions of the Equal Opportunity clause.
- (b) Subcontractors and material suppliers are cautioned as follows: By signing the subcontract or entering into a material supply agreement, the subcontractor or material supplier will be deemed to have signed and agreed to the provisions of the "Certification of Nonsegregated Facilities" in the subcontract or material supply agreement. This certification provides that the subcontractor or material supplier does not maintain or provide for his employees facilities which are segregated on the basis of race, creed, color, or national origin, whether such facilities are segregated by directive or on a de facto basis. The certification also provides that the subcontractor or material supplier will not maintain such segregated facilities.
- (c) Subcontractors or material suppliers receiving subcontract awards or material supply agreements exceeding \$10,000 which are not exempt from the provisions of the Equal Opportunity clause will be required to provide for the forwarding of this notice to prospective subcontractors for construction contracts and material suppliers where the subcontracts or material supply agreements exceed \$10,000 and are not exempt from the provisions of the Equal Opportunity clause.

9. PN 003 - 10/15/2004 - TITLE VI RELATED STATUTES NON-DISCRIMINATION STATEMENT

The LPA, under Title VI of the Civil Rights Act and related statutes, ensures that no person in the LPA, shall on the grounds of race, color, national origin, sex, disability or age be excluded from participation in, be denied the benefits of, or be otherwise subjected to discrimination under any program or activity it administers.

10. **CERTIFICATION OF COMPLIANCE WITH AFFIRMATIVE ACTION PROGRAMS**

In accordance with Ohio Administrative Code §9.47, before any Contract is awarded, the LPA will require the Bidder to furnish a valid Certificate of Compliance with Affirmative Action Programs, issued by the State EEO Coordinator dated prior to the date fixed for the opening of bids.

11. **PN 020 – 11/21/2011 - NOTICE OF REQUIREMENT OF AFFIRMATIVE ACTION TO ENSURE EQUAL EMPLOYMENT OPPORTUNITY**

The Bidder's attention is called to the affirmative action obligations required by the specifications set forth in 23 CFR Part 230, 41 CFR Part 60, Executive Order 11246, Section 503, and the affirmative action provisions of Vietnam Era Veterans' Readjustment Assistance Act (VEVRAA) of 1974.

Utilization goals applicable to the project, expressed in percentages, for minority and female participation for each construction craft can be found on ODOT's website at <http://www.dot.state.oh.us/Divisions/ContractAdmin/Contracts/Pages/default.aspx>. These goals are based on 2000 census data and represent the area, per craft, minority and female availability pool.

Minority and female utilization obligations by craft per county (applicable to project):

<http://www.dot.state.oh.us/Divisions/ContractAdmin/Contracts/Construction/CountyAvailability-ByTrade.pdf>

Statewide utilization obligations by craft (applicable to the Contractor's statewide workforce):

<http://www.dot.state.oh.us/Divisions/ContractAdmin/Contracts/Construction/StatewideAverages-ByTrade.pdf>

Effective 11/21/2011 the New Hire Definition will be as follows:

An individual who has a break in service (not on an employer's payroll) for a period of 12 months or longer and the person affected is not a salaried employee, but belongs to a union craft. Individuals compensated for training or incidental work which does not cause a break in unemployment compensation, i.e., paid by voucher check or petty cash, are considered new hires if the individual's break in service is 12 months or longer.

The time frame for a new hire shall be associated with the first project worked for that contractor regardless of whether it is public or private. When reporting new hires the contractor shall identify that employee as a new hire on that specific project only. Subsequent work, barring a break in service of 12 months or more, would not qualify the employee as a new hire for that contractor.

The Contractor's compliance shall be based on the implementation of affirmative action obligations required by the specifications set forth in 23 CFR Part 230, and its good faith efforts to meet these obligations. The hours of minority and female employment and training must be substantially uniform throughout the length of the contract, and in each trade, and the Contractor shall make a good faith effort to employ minorities and females on each of its projects. The transfer of minority or female employees or trainees from Contractor to Contractor or from project to project for the sole purpose of meeting the affirmative action obligations shall be a violation of the contract and regulations in 23 CFR Part 230. The good faith efforts put forth by the contractor will be measured against the total work hours performed. Under FHWA, ODOT is the authority tasked with ensuring that the contractor adheres to the aforementioned regulations. In addition to complying with the Required Contract Provisions as outlined in the attached subcontract agreement the Contractor shall provide immediate written notification to the ODOT and the Prime Contractor when referral practices of the union or unions with which the Contractor has a collective bargaining agreement impede the company's efforts to meet its equal opportunity obligations.

The Office of Federal Contract Compliance Programs (OFCCP) administers and enforces equal employment opportunity laws that apply to Federal government contractors and subcontractors supplying goods and services, including construction, to the Federal Government under 41 CFR Part 60, Executive Order 11246, Section 503, and the affirmative action provisions of VEVRAA. The OFCCP monitors compliance with these laws primarily through compliance evaluations, during which a compliance officer examines the contractor's affirmative action efforts and employment practices. Under Executive Order 11246, the OFCCP may perform contract compliance reviews on contractors involved with federally funded ODOT projects.

Requirements for affirmative action obligations governing OFCCP contract compliance reviews are those listed in the Federal Register for the Economic Area.

https://www.dol.gov/ofccp/TAGuides/new_contractors_guide.htm page E-32

The Department of Administrative Services (DAS), Equal Opportunity Division, is responsible for ensuring state contractors implement and adhere to the State of Ohio's affirmative action program pursuant to Ohio Administrative Code (OAC) 123:2-3-02. Specifically, this unit's responsibilities includes the issuance of certificates of compliance under ORC 9.47 and 153.08, conducting project site visits and compliance reviews (desk audits) to ensure contractors utilize minorities and women in the construction trades, as well as maintaining a working environment free of discrimination, harassment and intimidation. The DAS may perform contract compliance reviews on contractors involved with state funded ODOT projects. Requirements for affirmative action obligations governing DAS contract compliance reviews are those

listed in the O.A.C. for the Metropolitan Statistical Area in which a project is located. <http://das.ohio.gov/Divisions/EqualOpportunity/ConstructionCompliance.aspx>

All prime and subcontractors regardless on the number of employees or the state contract amount are required to submit monthly utilization reports (Input Form 29) to Ohio Department of Administrative Services covering the contractor's total workforce within the state of Ohio. The reports must be filed electronically by the 10th of each month, beginning with the contract award and continuing until the contractor or subcontractor completes performance of the state contract. <http://das.ohio.gov/Divisions/EqualOpportunity/InputForm29.aspx>

The Contractor shall provide written notification to the Director of the Office of Federal Contract Compliance Programs, 200 N. High Street, Room 409, Columbus, Ohio 43215, within 10 working days of award of any construction subcontract in excess of \$10,000 at any tier for construction work under the contract resulting from this solicitation. The notification shall list the name, address and telephone number of the subcontractor, employer identification number of the subcontractor, estimated dollar amount of the subcontract, estimated starting and completion dates of the subcontract and the geographical area in which the subcontract is to be performed.

12. PN 029 - 10/15/2004 - ON-THE JOB TRAINING (OJT) PILOT PROGRAM

The requirements of this Training Special Provision supersede subparagraph 7b of the Special Provision entitled Special Employment Opportunity Responsibilities, and implements 23 U.S.C. 140(a).

The following must be included as part of the Contractor's equal employment opportunity affirmative action training program:

The Contractor must provide on-the-job training aimed at developing full journey persons in the type or job classification in which they work.

The contractor is not required to have a specific number of trainees assigned to this project. The number of trainees will be distributed among the work classifications on the basis of the Contractor's needs and the availability of the journey persons in the various classifications. The Contractor will be credited for each trainee employed by him or her who is currently enrolled or becomes enrolled in an approved program.

Training and upgrading of minorities and women toward journey person status is a primary objective of this Training Special Provision. Accordingly, the Contractor must make every effort to enroll minority trainees and women (e.g., by conducting systematic and direct recruitment through public and private sources likely to yield minority and women trainees) to the extent that such persons are available within a reasonable area of recruitment. This training commitment is not intended, and will not be used, to discriminate against any applicant for training, regardless of whether the applicant is a member of a minority group or not.

No employee will be employed as a trainee in any classification in which he or she has successfully completed a training course leading to journey person status or in which he or she has been employed as a journey person. The Contractor must satisfy this requirement by including appropriate questions in the employee's application or by other suitable means. Regardless of the method used, the Contractor's records must document the findings in each case.

The minimum length and type of training for each classification will be established in the training program selected by the Contractor.

No payment by the LPA will be made to the Contractor for providing this training. However, if the Contractor fails to provide adequate training and cannot show good faith efforts on its part to provide

adequate training, it will be subject to a formal compliance review to determine the Contractor's efforts in meeting the EEO laws and regulations.

The Contractor must provide the following reports:

1. CR1 Report
 - A. To be completed on each trainee
 - B. To be filled out at the start of training and finish of training or at the end of the year, whichever comes first
 - C. To be submitted to the ODOT District in which the Contractor's home office is located.
2. Tracking will be on an annual basis. The Contractor must submit the subsequent CR1 to the ODOT District in which the Contractors home office is located.

The prime or subcontractor conducting the training must be involved in at least one Federal project per calendar year in order to get FHWA training credit. Participation in the OJT Program is not project or contract specific.

All Contractors are encouraged to participate in the OJT program. Such a program will be considered when examining the contractor's Good Faith Efforts toward meeting its contractual affirmative action obligations.

All Contractors shall submit their own Training Program or Apprenticeship Certificate, for approval, to the ODOT District in which the company's home office is located.

All OJT Trainees must have the appropriate certification. Apprenticeship Certificates can be obtained from the State of Ohio, Bureau of Apprenticeship and Training. The union apprenticeship agreement is not acceptable verification of an apprentice's enrollment in a union sponsored training program. A copy of the Apprenticeship Certificate along with a statement indicating the number of months/years the employee has been in the apprenticeship program must be submitted to the ODOT EEO Coordinator in the company's home district and to the prevailing wage coordinator in the district responsible for the project within 90 days of the apprentice beginning work on the project.

13. PN 059 - 10/15/2004 - WAGE DETERMINATION APPEALS PROCESS

- 1.) Has there been an initial decision in the matter? This can be:
 - * An existing published wage determination
 - * A survey underlying a wage determination
 - * A Wage and Hour Division letter setting forth a position on a wage determination matter
 - * A conformance (additional classification and rate) ruling

On survey related matters, initial contact, including requests for summaries of surveys, should be with the Wage and Hour Regional Office for the area in which the survey was conducted because those Regional Offices have responsibility for the Davis-Bacon survey program. If the response for this initial contact is not satisfactory, then the process described in 2.) and 3.) should be followed.

With regard to any other matter not yet ripe for the formal process described here, initial contact should be with the Branch of Construction Wage Determinations. Write to:

Branch of Construction Wage Determination
Wage and Hour Division
U. S. Department of Labor
200 Constitution Avenue, N.W.
Washington, D. C. 20210

- 2.) If the answer to the question in 1.) is yes, then an interested party (those affected by the action) can request review and reconsideration from the Wage and Hour Administrator (see 29 CFR Part 1.8 and 29 CFR Part 7). Write to:

Wage and Hour Administrator
U. S Department of Labor
200 Constitution Avenue, N.W.
Washington, D. C. 20210

The request should be accompanied by a full statement of the interested party's position and by any information (wage payment data, project description, area practice material, etc.) that the requester considers relevant to the issue.

- 3.) If the decision of the Administrator is not favorable, an interested party may appeal directly to the Administrative Review Board (formerly the Wage Appeals Board). Write to:

Administrative Review Board
U. S. Department of Labor
200 Constitution Avenue, N. W.
Washington, D. C. 20210

- 4.) All decisions by the Administrative Review Board are final.

14. PN 061 –10/22/2012- WAGE SCALE ON ALL FEDERAL-AID PROJECTS

The wage rates for this project were determined by the Secretary of Labor in accordance with Federal-Aid requirements. LPA must formally incorporate into contract documents.

Contractors shall use only the classifications and wage rates set forth in the United States Department of Labor (USDOL) wage decision found at website noted below on payrolls submitted to the District Office. Additionally, please note that the wage modification in effect at the time of the project sale date, shall be used by all contractors.

This USDOL wage decision may be viewed, by accessing the United States Department of Labor (USDOL) website at:

<http://www.wdol.gov/>

This contract requires the payment of the total of the basic hourly rates plus the fringe benefits payments for each classification in accordance with the following regulations which by reference are made part of this contract:

- 1) The U.S. Department of Labor Regulations, Title 29, Subtitle A, Part 5, Sections 5.5, 5.31, and 5.32, most recent revision at contract execution.
- 2) Form FHWA-1273 (most recent revision at contract execution) Part IV. Payment of Predetermined Minimum Wage and Part V. Statements and Payrolls.

The failure to pay prevailing wages to all laborers and mechanics employed on this project, shall be considered a breach of contract. Such a failure may result in the termination of the contract and debarment.

The Contractor and all subcontractors shall pay all wages and fringe benefits by company check. All payroll records and canceled pay checks shall be maintained for at least three years after final acceptance as defined in section 109.12 of the Ohio Department of Transportation Construction and Materials Specifications. The Contractor's and all subcontractors payroll records and canceled pay checks shall be made available for inspection by the Department and the U.S. Department of Labor, upon request, anytime

during the life of the contract, and for three years thereafter by the U.S. Department of Labor. Additionally, the Contractor and all subcontractors shall permit such representatives to interview any employees during working hours while the employee is on the job.

The wage and fringe rates determined for this project shall be posted by the Contractor in a prominent and accessible place on the project, field office, or equipment yard where they can be easily read by the workers.

The Contractor and all subcontractors shall submit to the District Construction Office, certified payrolls each week beginning three weeks after the start of work. These payrolls shall be on a Form WH-347 or equivalent and shall show the following:

- 1) Employee name, address, classification, and hours worked.
- 2) The basic hourly and overtime rate paid, total pay, and the manner in which fringe benefit payments have been irrevocably made.
- 3) The project number and pay week dates.
- 4) Original signature of a company officer on the certification statement.

Additionally, a copy of the "Apprentice Certification" obtained from the Ohio State Apprenticeship Council, must accompany all certified payrolls submitted for all apprentices working on this project.

Please be aware that it is ultimately the responsibility of the Contractor to ensure that all laws relating to prevailing wages in the USDOL Regulations, Title 29, parts 1 and 5, are strictly adhered to by all subcontractors on the project.

If the Contractor or any subcontractor fails to comply with any of the provisions contained in this proposal note, the Department may terminate the contract, debar the Contractor or Subcontractor and/or withhold or suspend pay estimates after written notice and a reasonable opportunity to comply has been provided.

The applicable wage and fringe rates for this project are to be incorporated in their entirety as an attachment to the executed contract.

15. LIMITATION ON USE OF CONTRACT FUNDS FOR LOBBYING

1. The prospective bidder certifies, by signing and submitting this bid proposal, to the best of his or her knowledge and belief, that:
 - (a.) No Federal appropriated funds have been paid or will be paid, by or on behalf of the undersigned, to any person for influencing or attempting to influence an officer or employee of any Federal agency, a Member of Congress, an officer or employee of Congress, or an employee of a member of Congress in connection with the awarding of any Federal contract, the making of any Federal grant, the making of any Federal loan, the entering into of any cooperative agreement, and the extension, continuation, renewal, amendment, or modification of any Federal contract, grant, loan, or cooperative agreement.
 - (b.) If any funds other than Federal appropriated funds have been paid or will be paid to any person for influencing or attempting to influence an officer or employee of any Federal agency, a Member of Congress, an officer or employee of Congress, or an employee of a Member of Congress in connection with this Federal contract, grant, loan, or cooperative agreement, the undersigned shall complete and submit Standard Form-LLL, "Disclosure Form to Report Lobbying" in accordance with its instructions.
2. This certification is a material representation of fact upon which reliance was placed when this transaction was made or entered into. This certification is a prerequisite for making or entering into this transaction imposed by Section 1352, Title 31, U.S. Code. Any person who fails to file

the required certification shall be subject to civil penalty of not less than \$10,000 and not more than \$100,000 for each such failure.

3. The prospective bidder also agrees by submitting his or her bid proposal that he or she shall require that the language of this certification be included in all lower tier subcontracts, which exceed \$100,000 and that all such subrecipients shall certify and disclose accordingly.

16. PN 045 - 10/15/2004 - NON -COLLUSION AFFIDAVIT

In accordance with Title 23 United States Code, Section 112 and Ohio Revised Code, Chapter 1331 et. seq: and Sections 2921.11 and 2921.13, the bidder hereby states, under penalty of perjury and under other such penalties as the law provides, that he or his agents or employees have not entered either directly or indirectly into any agreement, participated in any collusion, or otherwise taken any action in restraint of free competitive bidding in connection with this proposal. Execution of this proposal on the signature portion thereof shall constitute also signature of this Non-Collusion Affidavit as permitted by title 28 United States Code, Section 1746.

REPORTING BID RIGGING

To report bid rigging activities call:

1-800-424-9071

The U.S. Department of Transportation (DOT) operates the above toll-free "hotline" Monday through Friday, 8:00 a.m. to 5:00 p.m. eastern time. Anyone with knowledge of possible bid rigging, bidder collusion, or other fraudulent activities should use the "hotline" to report such activities.

The "hotline" is part of the DOT's continuing effort to identify and investigate highway construction contract fraud and abuse and is operated under the direction of the DOT Inspector General. All information will be treated confidentially, and caller anonymity will be respected.

17. PN 014 - 10/15/2004 - DRUG-FREE WORKPLACE

The prime contractor agrees to comply with all applicable state and federal laws regarding drug-free workplace. The prime contractor shall make a good faith effort to ensure that all its employees, while working on this project, will not purchase, transfer, use or possess illegal drugs or alcohol or abuse prescription drugs in any way.

The prime contractor shall also require that this contractual obligation be placed in all subcontractor and materialman contracts that it enters into and further requires that all subcontractors and materialmen place the same contractual obligations in each of their lower tier contracts.

18. PN 034 - 05/25/2011 – DRUG FREE SAFETY PROGRAM

During the life of this project, the Contractor and all its Subcontractors, that provide labor on the Project site, must be enrolled in and remain in good standing in the Ohio Bureau of Worker's Compensation ("OBWC") Drug-Free Safety Program ("DFSP") or a comparable program approved by the OBWC.

In addition to being enrolled in and in good standing in an OBWC-approved DFSP or a comparable Drug Free Workplace Program ("DFWP") approved by the OBWC, the LPA requires each Contractor and Subcontractor that provides labor, to subject its employees who perform labor on the project site to random drug testing of 5 percent of its employees. The random drug testing percentage must also include the on-site supervisors of the Contractors and Subcontractors. Upon request, the Contractor and Subcontractor shall provide evidence of required testing to the LPA.

Each Subcontractor shall require all lower-tier Subcontractors that provides labor on the project site with whom the Subcontractor is in contract for the Work to be enrolled in and be in good standing in the OBWC DFSP or an OBWC-approved DFWP prior to a lower-tier Subcontractor providing labor at the Site.

The LPA will declare a bid non-responsive and ineligible for award if the Contractor is not enrolled and in good standing in the Ohio Bureau of Workers' Compensation's DFSP Discount Program or a similar program approved by the Bureau of Workers' Compensation within 8 days of the bid opening. Furthermore, the LPA will deny all requests to sublet when the subcontractor does not comply with the provisions of this proposal note.

Failure of the Contractor to require a Subcontractor to be enrolled in and be in good standing in the OBWC DFSP or an OBWC-approved DFWP prior to the time that the Subcontractor provides labor at the Site, shall result in the Contractor being found in breach of the Contract and that breach shall be used in the responsibility analysis of that Contractor or the Subcontractor who was not enrolled in a program for future contracts with the State for five years after the date of the breach.

19. OHIO WORKERS' COMPENSATION COVERAGE

The Contractor must secure and maintain valid Ohio workers' compensation coverage until the project has been finally accepted by the Ohio Department of Transportation. A certificate of coverage evidencing valid workers' compensation coverage must be submitted to the LPA before the contract will be executed by the LPA.

The Contractor must immediately notify the LPA, in writing, if it or any subcontractor fails or refuses to renew their workers' compensation coverage. Furthermore, the Contractor must notify the LPA, in writing, if its or any of its subcontractor's workers' compensation policies are canceled, terminated or lapse.

The failure to maintain valid workers' compensation coverage shall be considered a breach of contract which may result in the Contractor or subcontractor being removed from the project, withholding of pay estimates and/or termination of the contract.

20. PN 038 - 10/15/2004 - UNRESOLVED FINDING FOR RECOVERY

The Contractor affirmatively represents to the LPA that it is not subject to a finding for recovery under Ohio Revised Code §9.24, or that it has taken the appropriate remedial steps required under §9.24 or otherwise qualifies under that section. The Contractor agrees that if this representation is deemed to be false, the contract shall be void ab initio as between the parties to this contract, and any funds paid by the state hereunder shall be immediately repaid to the LPA, or an action for recovery may be immediately commenced by the LPA and/or for recovery of said funds.

21. PN 039 - 10/15/2004 - ASSIGNMENT OF ANTITRUST CLAIMS IN STATE CONTRACT LANGUAGE

The Contractor should recognize that in actual economic practice, overcharges resulting from antitrust violations are usually borne by ODOT and/or the LPA. As consideration for the Award of the Contract and intent to be legally bound, the Contractor acting herein by and through the person signing this contract on behalf of the Contractor as a duly authorized agent, hereby assigns, sells, conveys, and transfers to ODOT and/or the LPA any and all right, title and interest to any and all claims and causes of action the Contractor now has or hereafter requires under state or federal antitrust laws provided that the claims or causes of action related to the goods or services that are the subject to the contract. In addition, the Contractor warrants and represents that it will require any and all of its subcontractors and first tier suppliers to assign any and all federal and state antitrust claims and causes of action to ODOT and/or the LPA. The provisions of this article shall become effective at the time the LPA executes this contract without further acknowledgment by any of the parties.

All contracting entities shall assign their rights and responsibilities to ODOT and/or the LPA for all antitrust claims and causes of action regarding subcontractors.

22. PN 024 – 04/21/2006 – US ARMY CORPS OF ENGINEERS AND OHIO ENVIRONMENTAL PROTECTION AGENCY PERMITS

The above referenced permits are incorporated and made a part of this contract as special provisions incorporated herein. Therefore, in the event that the Contractor or its agents refuse or fail to adhere to the requirements of the US Army Corps of Engineers 404 Permit, and/or the Ohio Environmental Protection Agency's 401 Water Quality Certification and an assessment or fine, is made or levied against the Ohio Department of Transportation, the Contractor shall reimburse the Department within thirty (30) calendar days of the notice of assessment or fine or the Department may withhold the amount of the fine from the Contractor's next pay estimate. All money collected or withheld from the Contractor shall be delivered to the permitting agencies issuing the assessment or fine.

These fines are not to be construed as a penalty but are liquidated damages to recover costs assessed against the Department due to the Contractor's refusal or failure to comply with the permits.

23. PN 007 – 07/19/2019 - DBE TRUCKING

The Code of Federal Regulations Title 49, Section 26.55(d)(4)(5)(6) governs trucking operations.

The DBE trucking firm must be able to quote and negotiate its own prices. The DBE trucking firm must also provide a quote for each project that the firm is to be utilized toward the project DBE goal.

The DBE will be responsible for the management and supervision of their trucking operation on each contract. A DBE is not performing a CUF if the contract exists for the purpose of creating the appearance of DBE participation.

The DBE must own and operate at least one fully licensed, insured, and operational truck used on the contract.

The DBE receives credit for the total value of the transportation services the DBE provides on the contract using trucks the DBE owns, insures, and operates using drivers it employs (not 1099/independent contractors).

The Disadvantaged Business Enterprise (DBE) may lease trucks on a long term basis (a year or more), and receive full DBE credit as long as employees of the DBE operate the truck.

A lease must indicate that the DBE has exclusive use of and control over the truck, including responsibility of maintenance and insurance. This does not preclude the leased truck from working for others during the term of the lease with the DBEs consent, as long as the lease gives the DBE absolute priority for use of the leased truck. Leased trucks must display the DBEs name and identification number as well.

The DBE must carry a copy of the lease agreement in the leased truck when working onsite.

Credit for expenditures with DBEs for materials or supplies toward the DBE goal is described as follows:

1. A DBE firm may be a regular dealer in bulk items such as petroleum products, steel, cement, gravel, stone, or asphalt without owning, operating, or maintaining a place of business if the firm both owns and operates distribution equipment for the products. Any supplementing of a regular dealer's own distribution equipment shall be by a long-term lease agreement and not on an *ad hoc* or contract-by-contract basis.

2. When the materials or supplies are obtained from a DBE MSV (Materials and Supplies Vendor) manufacturer the prime contractor may receive credit for 100 percent of the cost of the materials or supplies toward the DBE goal. For purposes of this section, a manufacturer is a firm that operates or maintains a factory or establishment that produces, on the premises, the materials, supplies, articles, or equipment required under the contract and of the general character described by the specifications.
3. When the materials or supplies are purchased from a DBE MSV regular dealer or supplier the prime contractor may receive credit for up to 60 percent of the cost of the materials or supplies toward the DBE goal. For purposes of this section, a regular dealer or supplier is a firm that owns, operates, or maintains a store, warehouse, or other establishment in which the materials, supplies, articles or equipment of the general character described by the specifications and required under the contract are bought, kept in stock, and regularly sold or leased to the public in the usual course of business.

In the past, 60% of the cost of materials and supplies purchased from a DBE MSV (100% from a DBE MSV manufacturer) would usually be counted toward DBE goals. **Effective September 1, 2018:**

- o Prime contractors must obtain information about the method of procurement for each item to be procured from a DBE MSV. The DBE Affirmation Form has been modified to accommodate this information.
- o To be eligible to receive **100% credit** toward DBE goals for a materials and supplies subcontract:
 - The DBE MSV must be certified with the correct (**manufacturer**) NAICS code for the item
 - The DBE MSV must be certified with the correct descriptor for the item
 - The role the DBE MSV will play on the specific procurement in question must be consistent with the **manufacture** of the item, as indicated by the information provided by the DBE MSV
- o To be eligible to receive **60% credit** toward DBE goals for a materials and supplies subcontract:
 - The DBE MSV must be certified with the correct (**wholesale or retail**) NAICS code for the item
 - The DBE MSV must be certified with the correct descriptor for the item
 - The role the DBE MSV will play on the specific procurement in question must be consistent with the **regular sale or lease** of the item, as indicated by the information provided by the DBE MSV
 - **The item must not be drop-shipped**
- o The above scenario applies to both bulk items (petroleum products, steel, cement, gravel, stone, asphalt, and others that ODOT may consider to be bulk items) and nonbulk items. For bulk items, there is an additional scenario whereby a contract with a DBE MSV could receive 60% credit. To be eligible to receive **60% credit** toward DBE goals for a bulk item materials and supplies subcontract:
 - The DBE MSV must be certified with the correct (**wholesale or retail and trucking**) NAICS codes for the item
 - The DBE MSV must be certified with the correct descriptor for the item
 - The role the DBE MSV will play on the specific procurement in question must be consistent with the **regular sale or lease** of the item, as indicated by the information provided by the DBE MSV
 - The DBE MSV must deliver the bulk item from a non-DBE vendor to the prime

contractor using distribution equipment that it both owns (or for which it has a long-term (1 year or more) lease) and operates with its regular (not ad hoc) employees.

- o If not eligible for 100% or 60% credit, an item may still be eligible for credit toward DBE goals, but only for the **fee or commission the DBE MSV receives for its services**, and only if the following additional criteria are met:
 - The DBE MSV must be certified with NAICS code 425120 Wholesale Trade Agents and Brokers
 - The DBE MSV must convincingly explain how the prime contractor benefits by transacting business with it rather than directly with the non-DBE vendor from which the DBE MSV is re-selling.
- The usual good faith efforts process applies.
- All credit toward DBE goals is conditional. Actual credit will be determined based upon invoices, receipts, and/or transportation documents/bills of lading, which must be submitted to ODOT as they are received throughout the course of the project.

DBE MSV DIRECTORY - <http://www.dot.state.oh.us/Divisions/ODI/SDBE/Pages/DBE-Directory.aspx>
(select MSV only)

DBE AFFIRMATION FORM - *The new DBE Affirmation Form is now available at*
<http://www.dot.state.oh.us/Divisions/ODI/SDBE/Pages/Resources.aspx>.

24. **PN 013 – 03/15/2019 - DISADVANTAGED BUSINESS ENTERPRISE (DBE) UTILIZATION PLAN AND GOOD FAITH EFFORTS**

DBE UTILIZATION PLAN

All Bidders shall submit a DBE Utilization Plan at the time of bid setting forth specific information demonstrating how the Bidder will achieve the DBE goal. By submitting a DBE Utilization Plan, the Bidder is affirming that they will be using the DBE firms identified in the Utilization Plan to meet the DBE contract goal. The DBE Utilization Plan shall be submitted with Formstack at time of bid submission. Any bids received without electronic submission of the DBE Utilization Plan at or before bid time, will be deemed unresponsive. **Bidders shall submit their DBE Utilization Plans via: https://odot.formstack.com/forms/dbe_copy.** This file contains the current list of certified DBEs and is updated regularly. The DBE Utilization Plan must be filled out completely and submitted prior to bid opening.

The DBE Utilization Plan shall include the following information:

- 1) The names and addresses of the certified DBE firm(s) that will be used to meet the DBE goal;
- 2) A description of the work that each DBE will perform. To count toward meeting a goal, each DBE firm must be certified in a NAICS code applicable to the kind of work the firm would perform on the contract;
- 3) Whether the DBE firm(s) being used to meet the goal will be utilized as a subcontractor, regular dealer, manufacturer, consultant or other capacity; and
- 4) The dollar amount of the participation of each DBE firm used to meet the DBE goal.

PROJECTS AWARDED ON ALTERNATES

In the event the project is awarded on alternates which increases or decreases the total dollar amount of the bid, a revision to the DBE Utilization Plan and DBE Affirmation Form(s) shall be submitted and approved by the

Office of Small & Disadvantaged Business Enterprise within five (5) calendar days after the notification of the alternates.

DBE AFFIRMATION

The Apparent Low Bidder shall ensure the DBE firms being utilized to meet the DBE goal affirm their participation in the bid within five (5) calendar days after the bid opening to ODOT. The contract dollar amount(s) and/or DBE firm(s) included in the Apparent Low Bidder's DBE Utilization Plan must match the contract dollar amount(s) and/or DBE firm(s) included on the DBE Affirmation Form(s). If the contract dollar amount(s) and/or DBE firm(s) do not match, the Apparent Low Bidder shall utilize the Request to Terminate/Substitute DBE Form located at

<http://Transportation.ohio.gov/Divisions/ODI/SDBE/Pages/Resources.aspx> and submit for review and approval by the Office of Small & Disadvantaged Business Enterprise within five (5) calendar days of the bid opening.

The Apparent Low Bidder shall utilize the DBE Affirmation Form located at

<http://Transportation.ohio.gov/Divisions/ODI/SDBE/Pages/Resources.aspx>. The DBE Affirmation Form will be utilized as written confirmation from each listed DBE firm that it is participating in the contract in the type and amount of work provided in the Bidder's DBE Utilization Plan. The Apparent Low Bidder shall submit a separate DBE Affirmation Form for each DBE it is utilizing for the DBE goal and their Good Faith Efforts package if they were not able to attain the DBE Goal via DBE participation.

All other Bidders shall submit a DBE Affirmation Form(s) if notified that the information is required in order for ODOT to complete its assessment. Bidders shall have five (5) calendar days from the date of notification to submit all required DBE Affirmation Forms to ODOT. Notification will be by email.

In the event a DBE firm fails to confirm the information contained in the DBE Affirmation Form within five (5) calendar days of bid opening, the Apparent Low Bidder shall submit a Request to Terminate/Substitute DBE Form, as set forth herein. The Request to Terminate/Substitute DBE Form shall be submitted within five (5) calendar days after bid opening in order for the Apparent Low Bidder to still be considered for contract award. The Apparent Low Bidder shall include as its reason for termination the DBE firm's failure to provide a timely affirmation and should include all efforts the Apparent Low Bidder made to obtain the affirmation from the DBE firm and shall attach proof of these efforts, if available. If the Apparent Low Bidder intends to replace the DBE Firm, it shall include the replacement firm's information on the form. In the event the Apparent Low Bidder is unable to affirm a DBE firm included in its original DBE Utilization Plan at bid submission and it results in a goal shortfall, Good Faith Efforts (GFE's) must be submitted by the fifth calendar day after bid opening. All GFE documentation submitted for consideration should demonstrate the efforts the Bidder made prior to the time of bid submission to secure sufficient DBE participation on the project to meet the DBE goal although the Bidder was unable to do so. A DBE firm's failure to timely confirm information contained in the DBE Affirmation Form will be considered as good cause to terminate the DBE firm and will also be considered a part of the Apparent Low Bidder's Good Faith Efforts in meeting the goal.

DBE BIDDERS

In the event that the Bidder is also a certified DBE firm, the Bidder is required to complete a DBE Utilization Plan as set forth above. In this instance, however, the certified DBE Bidder would not need to submit a DBE Affirmation Form for the work it is planning to self-perform in order to meet the goal. ODOT will consider the submission of the bid as the certified DBE Bidder's written confirmation that it is participating in the contract. However, a DBE Affirmation Form must be submitted for all other DBE firms that are being utilized toward the DBE goal.

JOINT VENTURES

In the event that the Bidder is a Joint Venture, the Joint Venture will only be considered a Certified DBE firm if the Joint Venture itself has been certified. The Joint Venture may, however, utilize a Certified DBE firm that is also a partner in the Joint Venture as part of its DBE Utilization Plan. The Certified DBE Firm/Joint Venture Partner, however, does not need to submit a DBE Affirmation Form for any work that the Certified DBE Firm/Joint Venture Partner is going to perform to meet the goal. ODOT will consider submission of the Joint Venture's bid as the Certified DBE Firm/Joint Venture Partner's confirmation that it is participating in the contract.

GOOD FAITH EFFORTS (GFE's)

In the event that the DBE contract goal established by ODOT is not met, the Apparent Low Bidder shall demonstrate that it made adequate good faith efforts to meet the goal, even though it did not succeed in obtaining enough DBE participation to do so.

If the Apparent Low Bidder does not meet the goal at bid time, the Apparent Low Bidder shall submit its Good Faith Efforts (GFE's) documentation within five (5) calendar days of the bid opening. Submission of DBE affirmation(s) with additional participation sufficient to meet the DBE contract goal does not cure the Apparent Low Bidder's failure to meet the goal at bid time or eliminate the Apparent Low Bidder's responsibility of submitting GFE's within five (5) calendar days of the bid opening.

The Apparent Low Bidder shall demonstrate its GFE's by submitting the following information within five (5) calendar days after the bid opening:

- (1) All written quotes received from certified DBE firms;
- (2) All written (including email) communications between the Apparent Low Bidder and DBE firms;
- (3) All written solicitations to DBE firms, even if unsuccessful;
- (4) Copies of each non-DBE quote when a non-DBE was selected over a DBE for work on the contract;
- (5) Phone logs of communications with DBE firms.

The Apparent Low Bidder shall utilize the Pre-Bid GFE Template to document their GFE's. This template and supporting documentation shall be sent along with any DBE Affirmation Forms within five (5) calendar days of bid opening. ODOT has provided Good Faith Efforts Guidance located at <http://Transportation.ohio.gov/Divisions/ODI/SDBE/Pages/Resources.aspx>.

All other Bidders shall submit documentation of GFE's if notified that the information is required in order for ODOT to complete its bid assessment. Bidders shall have five (5) calendar days from the date of notification to submit all required GFE documentation. Notification will be by phone or email.

ODOT shall utilize the guidance set forth in 49 CFR §26.53 Appendix A in determining whether the Bidder has made adequate good faith efforts to meet the goal.

ADMINISTRATIVE RECONSIDERATION

ODOT will review the GFE documentation and issue a written determination on whether adequate GFE's have been demonstrated prior to contract award. If ODOT determines that the Apparent Low Bidder has failed to demonstrate adequate GFE's to meet the goal, the Apparent Low Bidder will have an opportunity for administrative reconsideration prior to the contract being awarded.

As part of this reconsideration, the Apparent Low Bidder may provide written documentation or argument concerning the issue of whether it met the goal or made adequate good faith efforts to do so. Such written documentation or argument must be provided to ODOT, attention to the Office of Chief Legal Counsel, 1980 West Broad Street, MS 1500, Columbus, Ohio 43223 (with copy to the Office of Contract Sales, MS 4110), within two (2) business days of ODOT's written determination that GFE's were not adequately demonstrated. The Apparent Low Bidder may also include in their written documentation a request for an in person meeting to discuss the issue of whether it met the goal or made adequate good faith efforts to do so. ODOT's Office of Chief

Legal Counsel will respond to the Apparent Low Bidder within five (5) business days of receiving written documentation or holding the in-person meeting.

ODOT will send the Apparent Low Bidder a written decision on reconsideration explaining the basis for finding that the Apparent Low Bidder did or did not meet the goal or make adequate good faith efforts to do so. The result of the reconsideration process is not administratively appealable to the United States Department of Transportation.

TERMINATION OR REPLACEMENT OF A DBE

By submitting a DBE Utilization Plan, the Bidder is committing to use the DBE firms identified in the plan. The Apparent Low Bidder/Awarded Contractor shall utilize the specific DBEs listed in the DBE Utilization Plan to perform the work and supply the materials for which each is listed unless the Apparent Low Bidder/Awarded Contractor obtains written consent as provided in this paragraph. In order to request termination or substitution of a DBE firm, the Apparent Low Bidder/Awarded Contractor shall utilize the Request to Terminate/Substitute DBE Form located at <http://Transportation.ohio.gov/Divisions/ODI/SDBE/Pages/Resources.aspx>

This termination/replacement procedure applies only to DBE firms or the amount of work being utilized to meet the goal.

Without ODOT's written consent to terminate/replace a DBE firm being utilized to meet the goal, the Awarded Contractor shall not be entitled to any payment for DBE listed work or material unless it is performed or supplied by the listed DBE.

GOOD CAUSE

ODOT may provide written consent to terminate a DBE only if it agrees, for reasons stated in a concurrence document, that the Apparent Low Bidder/Awarded Contractor has good cause to terminate the DBE firm.

For purposes of this paragraph, good cause to terminate a DBE includes the following circumstances:

- 1) The listed DBE firm fails or refuses to provide the required DBE Affirmation Form or to execute a written contract;
- 2) The listed DBE firm fails or refuses to perform the work of its subcontract in a manner consistent with normal industry standards. Provided, however, that good cause does not exist if the failure or refusal of the DBE firm to perform its work on the subcontract results from the bad faith or discriminatory action of the awarded contractor;
- 3) The listed DBE firm fails or refuses to meet the awarded contractor's reasonable, nondiscriminatory bond requirements.
- 4) The listed DBE firm becomes bankrupt, insolvent, or exhibits credit unworthiness;
- 5) The listed DBE firm is ineligible to work on public works projects because of suspension and debarment proceedings pursuant 2 CFR Parts 180, 215 and 1200 or applicable state law;
- 6) ODOT has determined that the listed DBE firm is not a responsible contractor;
- 7) The listed DBE firm voluntarily withdraws from the project and provides to you written notice of its withdrawal;
- 8) The listed DBE is ineligible to receive DBE credit for the type of work required;
- 9) A DBE owner dies or becomes disabled with the result that the listed DBE contractor is unable to complete its work on the contract; and
- 10) Other documented good cause that ODOT determines compels the termination of the DBE firm. Provided, that good cause does not exist if the awarded contractor seeks to terminate a DBE it relied upon to obtain the contract so that the awarded contractor can self-perform the work for which the DBE contractor was engaged or so that the awarded contractor can substitute another DBE or non-DBE contractor after contract award.

REPLACEMENT

When a DBE firm is terminated or fails to complete its work on the contract for any reason the Awarded Contractor must make GFEs to find another DBE firm to replace the original DBE. These GFEs shall be directed at finding another DBE to perform at least the same amount of work under the contract as the DBE that was terminated, to the extent needed to meet the contract goal. The GFEs shall be documented by the Awarded Contractor. If ODOT requests documentation under this provision, the Awarded Contractor shall submit the documentation within seven (7) calendar days, which may be extended for an additional seven (7) calendar days if necessary at the request of the contractor, and ODOT shall provide a written determination to the contractor stating whether or not GFEs have been demonstrated.

In addition to post-award terminations, the provisions of this section apply to pre-award deletions and substitutions of DBE firms put forward by Bidders in the DBE Utilization Plan.

ADDITION

In the event additional DBE participation is required for the project, the Awarded Contractor shall utilize the DBE Affirmation Form located at <http://Transportation.ohio.gov/Divisions/ODI/SDBE/Pages/Resources.aspx>. The DBE Affirmation Form will be utilized as written confirmation from each DBE firm that it is participating in the contract in the kind and amount of work on the project.

WRITTEN NOTICE TO DBE

Before transmitting to ODOT its request to terminate and/or substitute a DBE firm, the Apparent Low Bidder/Awarded Contractor must give notice in writing to the DBE firm, with a copy to ODOT, of its intent to request to terminate and/or substitute, and the reason(s) for the request.

The Apparent Low Bidder/Awarded Contractor must give the DBE five (5) calendar days to respond to the notice, advising ODOT and the Apparent Low Bidder/Awarded Contractor of the reasons, if any, why it objects to the proposed termination of its subcontract and why ODOT should not approve the Apparent Low Bidder/Awarded Contractor's action. If required in a particular case as a matter of public necessity (e.g., safety), ODOT may provide a response period shorter than five (5) days.

GOAL ATTAINMENT POST AWARD

The Awarded Contractor shall make available upon request a copy of all DBE subcontracts. The Awarded Contractor shall ensure that all subcontracts or agreements with DBEs require that the subcontract and all lower tier subcontractors be performed in accordance with this Proposal Note.

Approval of a DBE Utilization Plan does not ensure approval of C-92 Requests to Sublet nor does approval of a DBE Utilization Plan indicate that the DBE goal has been met. ODOT will monitor goal attainment throughout the life of the project. It is the responsibility of the Awarded Contractor to advise ODOT of any changes to the DBE Utilization plan throughout the life of the project. The DBE goal of a project is stated as a percentage of the contract. In the event the contract amount increases or decreases, the actual dollar amount of the DBE goal for the project may increase or decrease accordingly.

SANCTIONS AND ADMINISTRATIVE REMEDIES

PRE-BID

Failure by the Apparent Low Bidder to do any of the following shall result in the bid being rejected in accordance with ORC §5525.08:

- 1) Failure to submit a complete DBE Utilization Plan at the time of bid;
- 2) Failure to submit DBE Affirmation Form(s) and/or failure to submit Request to Terminate/Substitute DBE Form(s) as required by this Proposal Note; and
Failure to meet the goal and/or failure to demonstrate GFEs to meet the goal as required by this Proposal Note.

POST-BID

Failure by the Awarded Contractor to carry out the requirements of this Proposal Note, including the submission of adequate good faith efforts to meet the goal for a project, is a material breach of the contract and may result in the issuance of sanctions as follows:

- | | |
|-----------|--|
| 1st Tier: | Letter of Reprimand |
| 2nd Tier: | Damages equivalent to the DBE shortfall |
| 3rd Tier: | If a pattern of paying damages persists or the Contractor has falsified, misrepresented or withheld information, ODOT can pursue other remedies available by law including suspension, revocation, and/or debarment. |

Factors to be considered in issuing sanctions may include, but are not limited to the following:

- the magnitude and the type of offense
- the degree of the Contractor’s culpability
- any steps taken to rectify
- the Contractor’s record of performance on other projects including, but not limited to:
 - annual DBE participation
 - annual DBE participation on projects without goals
 - the number of complaints ODOT has received regarding the Contractor
 - the number of times the Contractor has been previously sanctioned by ODOT

25. PN - 031 - 10/15/2004 - AFFIDAVIT OF SUBCONTRACTOR PAYMENT

(Required if DBE goal on the project)

The Code of Federal Regulations 49, 26.37(b), requires the LPA to monitor and verify that work committed to Disadvantaged Business Enterprise (DBE) firms at contract award is actually performed by the DBE’s. Additionally, the LPA is required to report the DBE participation on each project, including all work, materials or service sublets. Therefore, it is the LPA’s responsibility to discern whether payments are made to DBE firms. An affidavit is to be completed and signed by the contractor within 15 days of the completion of the project. The affidavit seeks to verify actual payments made to DBE firms on the project. Each DBE firm must verify the actual payment amount.

The blank spaces in the affidavit must be filled in correctly, where indicated. The affidavit must be signed by the prime contractor and subcontractor, or by the subcontractor and DBE sub-contractor, if applicable. By signing the affidavit, the noted firm agrees that the payment amount recorded is true and accurate as of the payment time period.

Completed and signed affidavit shall be mailed to the Ohio Department of Transportation, Office of Contracts, DBE Services section, 1980 West Broad Street, Columbus, Ohio 43223. A color scan of the affidavit may be sent in advance to Central Office, to keep project moving forward. However, the originals will still need to be mailed to Central Office.

26. WAIVER OF CM&S 614.03

ODOT's 2016 Construction and Material Specifications section 614.03, third paragraph, does not apply to any project which is not physically located on the National Highway System (NHS), and/or does not impact NHS traffic in any way.

27. ODOT AS OBLIGEE ON BOND

The contractor shall furnish a performance and payment bond in an amount at least equal to 100 percent of the estimate as security for the faithful performance of its contract. In addition to the project Owner, ODOT shall be named as an obligee.

28. NON-DISCRIMINATION PROVISIONS

1) **Compliance with Regulations:** The CONTRACTOR will comply with the regulations relative to nondiscrimination in Federally-assisted programs of the United States Department of Transportation (hereinafter "U.S. DOT") Title 49, Code of Federal Regulations, Part 21, as they may be amended from time to time, (hereinafter referred to as the "Regulations"), which are herein incorporated by reference and made a part of this contract.

In addition, the CONTRACTOR will comply with the provisions of the Americans with Disabilities Act, Section 504 of the Rehabilitation Act, FHWA Guidance, and any other Federal, State, and/or local laws, rules and/or regulations (hereinafter referred to as "ADA/504").

(2) **Nondiscrimination:** The CONTRACTOR, with regard to the work performed by it during the contract, will not discriminate on the grounds of race, color, national origin, sex, age, or disability, in the selection and retention of subcontractors, including procurements of materials and leases of equipment. The CONTRACTOR will not participate either directly or indirectly in the discrimination prohibited by section 21.5 of the Regulations, including employment practices when the contract covers a program set forth in Appendix B of the Regulations, as well as the ADA/504 regulations.

(3) **Solicitations for Contractors or Subcontractors, including Procurement of Materials and Equipment:** In all solicitations either by competitive bidding or negotiation made by the CONTRACTOR for work to be performed under a contract or subcontract, including procurements of materials or leases of equipment, each potential subcontractor, or supplier will be notified by the CONTRACTOR of the CONTRACTOR's obligations under this contract and the Regulations relative to nondiscrimination on the grounds of race, color, national origin, sex, age, or disability.

(4) **Information and Reports:** The CONTRACTOR will provide all information and reports required by the Regulations or directives issued pursuant thereto, and will permit access to its books, records, accounts, other sources of information, and its facilities as may be determined by the STATE or the Federal Highway Administration (hereinafter "FHWA") to be pertinent to ascertain compliance with such Regulations, orders and instructions. Where any information required of the CONTRACTOR is in the exclusive possession of another who fails or refuses to furnish this information, the CONTRACTOR will so certify to the STATE or FHWA, as appropriate, and will set forth what efforts it has made to obtain the information.

(5) **Sanctions for Noncompliance:** In the event of the CONTRACTOR's noncompliance with the nondiscrimination provisions of this contract, the LPA will impose such contract sanctions as it or STATE / FHWA may determine to be appropriate, including, but not limited to:

- (a) Withholding of payments to the CONTRACTOR under the contract until the CONTRACTOR complies, and/or
- (b) Cancellation, termination or suspension of the contract, in whole or in part.

(6) **Incorporation of Provisions:** The CONTRACTOR will include the provisions of paragraphs (1) through (5) above in every contract or subcontract, including procurements of materials and leases of equipment, unless exempt by the Regulations, or directives issued pursuant thereto. The CONTRACTOR will take such action with respect to any subcontractor procurement as the LPA or STATE / FHWA may direct as a means of enforcing such provisions including sanctions for noncompliance; provided, however, that, in the event the CONTRACTOR becomes involved in, or is threatened with, litigation with a subcontractor, or supplier as a result of such direction, the CONTRACTOR may request the LPA / STATE to enter into such litigation to protect the interests of the LPA and the STATE, and, in addition, the LPA / STATE may request the United States to enter into such litigation to protect the interests of the United States.

29. REQUIRED CONTRACT PROVISIONS FOR FEDERAL-AID CONSTRUCTION CONTRACTS (Electronic Form FHWA 1273 – May 1, 2012)

- I. General
- II. Nondiscrimination
- III. Nonsegregated Facilities
- IV. Davis-Bacon and Related Act Provisions
- V. Contract Work Hours and Safety Standards Act Provisions
- VI. Subletting or Assigning the Contract
- VII. Safety: Accident Prevention
- VIII. False Statements Concerning Highway Projects
- IX. Implementation of Clean Air Act and Federal Water Pollution Control Act
- X. Compliance with Government wide Suspension and Debarment Requirements
- XI. Certification Regarding Use of Contract Funds for Lobbying

Form FHWA-1273 must be included in all Federal-aid design-build contracts, in all subcontracts and in lower tier subcontracts (excluding subcontracts for design services, purchase orders, rental agreements and other agreements for supplies or services). The design-builder shall be responsible for compliance by any subcontractor, lower-tier subcontractor or service provider.

Contracting agencies may reference Form FHWA-1273 in bid proposal or request for proposal documents, however, the Form FHWA-1273 must be physically incorporated (not referenced) in all contracts, subcontracts and lower-tier subcontracts (excluding purchase orders, rental agreements and other agreements for supplies or services related to a construction contract).

2. Subject to the applicability criteria noted in the following sections, these contract provisions shall apply to all work performed on the contract by the contractor's own organization and with the assistance of workers under the contractor's immediate superintendence and to all work performed on the contract by piecework, station work, or by subcontract.

3. A breach of any of the stipulations contained in these Required Contract Provisions may be sufficient grounds for withholding of progress payments, withholding of final payment, termination of the contract, suspension / debarment or any other action determined to be appropriate by the contracting agency and FHWA.

4. Selection of Labor: During the performance of this contract, the contractor shall not use convict labor for any purpose within the limits of a construction project on a Federal-aid highway unless it is labor performed by convicts who are on parole, supervised release, or probation. The term Federal-aid highway does not include roadways functionally classified as local roads or rural minor collectors.

ATTACHMENTS

- A. Employment and Materials Preference for Appalachian Development Highway System or Appalachian Local Access Road Contracts (included in Appalachian contracts only)

I. GENERAL

1. Form FHWA-1273 must be physically incorporated in each construction contract funded under Title 23 (excluding emergency contracts solely intended for debris removal). The contractor (or subcontractor) must insert this form in each subcontract and further require its inclusion in all lower tier subcontracts (excluding purchase orders, rental agreements and other agreements for supplies or services).

The applicable requirements of Form FHWA-1273 are incorporated by reference for work done under any purchase order, rental agreement or agreement for other services. The prime contractor shall be responsible for compliance by any subcontractor, lower-tier subcontractor or service provider.

II. NONDISCRIMINATION

The provisions of this section related to 23 CFR Part 230 are applicable to all Federal-aid construction contracts and to all

related construction subcontracts of \$10,000 or more. The provisions of 23 CFR Part 230 are not applicable to material supply, engineering, or architectural service contracts.

In addition, the contractor and all subcontractors must comply with the following policies: Executive Order 11246, 41 CFR 60, 29 CFR 1625-1627, Title 23 USC Section 140, the Rehabilitation Act of 1973, as amended (29 USC 794), Title VI of the Civil Rights Act of 1964, as amended, and related regulations including 49 CFR Parts 21, 26 and 27; and 23 CFR Parts 200, 230, and 633.

The contractor and all subcontractors must comply with: the requirements of the Equal Opportunity Clause in 41 CFR 60-1.4(b) and, for all construction contracts exceeding \$10,000, the Standard Federal Equal Employment Opportunity Construction Contract Specifications in 41 CFR 60-4.3.

Note: The U.S. Department of Labor has exclusive authority to determine compliance with Executive Order 11246 and the policies of the Secretary of Labor including 41 CFR 60, and 29 CFR 1625-1627. The contracting agency and the FHWA have the authority and the responsibility to ensure compliance with Title 23 USC Section 140, the Rehabilitation Act of 1973, as amended (29 USC 794), and Title VI of the Civil Rights Act of 1964, as amended, and related regulations including 49 CFR Parts 21, 26 and 27; and 23 CFR Parts 200, 230, and 633.

The following provision is adopted from 23 CFR 230, Appendix A, with appropriate revisions to conform to the U.S. Department of Labor (US DOL) and FHWA requirements.

1. Equal Employment Opportunity: Equal employment opportunity (EEO) requirements not to discriminate and to take affirmative action to assure equal opportunity as set forth under laws, executive orders, rules, regulations (28 CFR 35, 29 CFR 1630, 29 CFR 1625-1627, 41 CFR 60 and 49 CFR 27) and orders of the Secretary of Labor as modified by the provisions prescribed herein, and imposed pursuant to 23 U.S.C. 140 shall constitute the EEO and specific affirmative action standards for the contractor's project activities under this contract. The provisions of the Americans with Disabilities Act of 1990 (42 U.S.C. 12101 et seq.) set forth under 28 CFR 35 and 29 CFR 1630 are incorporated by reference in this contract. In the execution of this contract, the contractor agrees to comply with the following minimum specific requirement activities of EEO:

a. The contractor will work with the contracting agency and the Federal Government to ensure that it has made every good faith effort to provide equal opportunity with respect to all of its terms and conditions of employment and in their review of activities under the contract.

b. The contractor will accept as its operating policy the following statement:

"It is the policy of this Company to assure that applicants are employed, and that employees are treated during employment, without regard to their race, religion, sex, color, national origin, age or disability. Such action shall include: employment, upgrading, demotion, or transfer; recruitment or recruitment advertising; layoff or termination; rates of pay or other forms of compensation; and selection for training, including apprenticeship, pre-apprenticeship, and/or on-the-job training."

2. EEO Officer: The contractor will designate and make known to the contracting officers an EEO Officer who will have the responsibility for and must be capable of effectively administering and promoting an active EEO program and who must be assigned adequate authority and responsibility to do so.

3. Dissemination of Policy: All members of the contractor's staff who are authorized to hire, supervise, promote, and discharge employees, or who recommend such action, or who are substantially involved in such action, will be made fully cognizant of, and will implement, the contractor's EEO policy and contractual responsibilities to provide EEO in each grade and classification of employment. To ensure that the above agreement will be met, the following actions will be taken as a minimum:

a. Periodic meetings of supervisory and personnel office employees will be conducted before the start of work and then not less often than once every six months, at which time the contractor's EEO policy and its implementation will be reviewed and explained. The meetings will be conducted by the EEO Officer.

b. All new supervisory or personnel office employees will be given a thorough indoctrination by the EEO Officer, covering all major aspects of the contractor's EEO obligations within thirty days following their reporting for duty with the contractor.

c. All personnel who are engaged in direct recruitment for the project will be instructed by the EEO Officer in the contractor's procedures for locating and hiring minorities and women.

d. Notices and posters setting forth the contractor's EEO policy will be placed in areas readily accessible to employees, applicants for employment and potential employees.

e. The contractor's EEO policy and the procedures to implement such policy will be brought to the attention of employees by means of meetings, employee handbooks, or other appropriate means.

4. Recruitment: When advertising for employees, the contractor will include in all advertisements for employees the notation: "An Equal Opportunity Employer." All such advertisements will be placed in publications having a large circulation among minorities and women in the area from which the project work force would normally be derived.

a. The contractor will, unless precluded by a valid bargaining agreement, conduct systematic and direct recruitment through public and private employee referral sources likely to yield qualified minorities and women. To meet this requirement, the contractor will identify sources of potential minority group employees, and establish with such identified sources procedures whereby minority and women applicants may be referred to the contractor for employment consideration.

b. In the event the contractor has a valid bargaining agreement providing for exclusive hiring hall referrals, the contractor is expected to observe the provisions of that agreement to the extent that the system meets the contractor's compliance with EEO contract provisions. Where implementation of such an agreement has the effect of discriminating against minorities or women, or obligates

the contractor to do the same, such implementation violates Federal nondiscrimination provisions.

c. The contractor will encourage its present employees to refer minorities and women as applicants for employment. Information and procedures with regard to referring such applicants will be discussed with employees.

5. Personnel Actions: Wages, working conditions, and employee benefits shall be established and administered, and personnel actions of every type, including hiring, upgrading, promotion, transfer, demotion, layoff, and termination, shall be taken without regard to race, color, religion, sex, national origin, age or disability. The following procedures shall be followed:

a. The contractor will conduct periodic inspections of project sites to insure that working conditions and employee facilities do not indicate discriminatory treatment of project site personnel.

b. The contractor will periodically evaluate the spread of wages paid within each classification to determine any evidence of discriminatory wage practices.

c. The contractor will periodically review selected personnel actions in depth to determine whether there is evidence of discrimination. Where evidence is found, the contractor will promptly take corrective action. If the review indicates that the discrimination may extend beyond the actions reviewed, such corrective action shall include all affected persons.

d. The contractor will promptly investigate all complaints of alleged discrimination made to the contractor in connection with its obligations under this contract, will attempt to resolve such complaints, and will take appropriate corrective action within a reasonable time. If the investigation indicates that the discrimination may affect persons other than the complainant, such corrective action shall include such other persons. Upon completion of each investigation, the contractor will inform every complainant of all of their avenues of appeal.

6. Training and Promotion:

a. The contractor will assist in locating, qualifying, and increasing the skills of minorities and women who are applicants for employment or current employees. Such efforts should be aimed at developing full journey level status employees in the type of trade or job classification involved.

b. Consistent with the contractor's work force requirements and as permissible under Federal and State regulations, the contractor shall make full use of training programs, i.e., apprenticeship, and on-the-job training programs for the geographical area of contract performance. In the event a special provision for training is provided under this contract, this subparagraph will be superseded as indicated in the special provision. The contracting agency may reserve training positions for persons who receive welfare assistance in accordance with 23 U.S.C. 140(a).

c. The contractor will advise employees and applicants for employment of available training programs and entrance requirements for each.

d. The contractor will periodically review the training and promotion potential of employees who are minorities and women and will encourage eligible employees to apply for such training and promotion.

7. Unions: If the contractor relies in whole or in part upon unions as a source of employees, the contractor will use good faith efforts to obtain the cooperation of such unions to increase opportunities for minorities and women. Actions by the contractor, either directly or through a contractor's association acting as agent, will include the procedures set forth below:

a. The contractor will use good faith efforts to develop, in cooperation with the unions, joint training programs aimed toward qualifying more minorities and women for membership in the unions and increasing the skills of minorities and women so that they may qualify for higher paying employment.

b. The contractor will use good faith efforts to incorporate an EEO clause into each union agreement to the end that such union will be contractually bound to refer applicants without regard to their race, color, religion, sex, national origin, age or disability.

c. The contractor is to obtain information as to the referral practices and policies of the labor union except that to the extent such information is within the exclusive possession of the labor union and such labor union refuses to furnish such information to the contractor, the contractor shall so certify to the contracting agency and shall set forth what efforts have been made to obtain such information.

d. In the event the union is unable to provide the contractor with a reasonable flow of referrals within the time limit set forth in the collective bargaining agreement, the contractor will, through independent recruitment efforts, fill the employment vacancies without regard to race, color, religion, sex, national origin, age or disability; making full efforts to obtain qualified and/or qualifiable minorities and women. The failure of a union to provide sufficient referrals (even though it is obligated to provide exclusive referrals under the terms of a collective bargaining agreement) does not relieve the contractor from the requirements of this paragraph. In the event the union referral practice prevents the contractor from meeting the obligations pursuant to Executive Order 11246, as amended, and these special provisions, such contractor shall immediately notify the contracting agency.

8. Reasonable Accommodation for Applicants / Employees with Disabilities: The contractor must be familiar with the requirements for and comply with the Americans with Disabilities Act and all rules and regulations established there under. Employers must provide reasonable accommodation in all employment activities unless to do so would cause an undue hardship.

9. Selection of Subcontractors, Procurement of Materials and Leasing of Equipment: The contractor shall not discriminate on the grounds of race, color, religion, sex, national origin, age or disability in the selection and retention of subcontractors, including procurement of materials and leases of equipment. The contractor shall take all necessary and reasonable steps to ensure nondiscrimination in the administration of this contract.

a. The contractor shall notify all potential subcontractors and suppliers and lessors of their EEO obligations under this contract.

b. The contractor will use good faith efforts to ensure subcontractor compliance with their EEO obligations.

10. Assurance Required by 49 CFR 26.13(b):

a. The requirements of 49 CFR Part 26 and the State DOT's U.S. DOT-approved DBE program are incorporated by reference.

b. The contractor or subcontractor shall not discriminate on the basis of race, color, national origin, or sex in the performance of this contract. The contractor shall carry out applicable requirements of 49 CFR Part 26 in the award and administration of DOT-assisted contracts. Failure by the contractor to carry out these requirements is a material breach of this contract, which may result in the termination of this contract or such other remedy as the contracting agency deems appropriate.

11. Records and Reports: The contractor shall keep such records as necessary to document compliance with the EEO requirements. Such records shall be retained for a period of three years following the date of the final payment to the contractor for all contract work and shall be available at reasonable times and places for inspection by authorized representatives of the contracting agency and the FHWA.

a. The records kept by the contractor shall document the following:

(1) The number and work hours of minority and non-minority group members and women employed in each work classification on the project;

(2) The progress and efforts being made in cooperation with unions, when applicable, to increase employment opportunities for minorities and women; and

(3) The progress and efforts being made in locating, hiring, training, qualifying, and upgrading minorities and women;

b. The contractors and subcontractors will submit an annual report to the contracting agency each July for the duration of the project, indicating the number of minority, women, and non-minority group employees currently engaged in each work classification required by the contract work. This information is to be reported on [Form FHWA-1391](#). The staffing data should represent the project work force on board in all or any part of the last payroll period preceding the end of July. If on-the-job training is being required by special provision, the contractor will be required to collect and report training data. The employment data should reflect the work force on board during all or any part of the last payroll period preceding the end of July.

III. NONSEGREGATED FACILITIES

This provision is applicable to all Federal-aid construction contracts and to all related construction subcontracts of \$10,000 or more.

The contractor must ensure that facilities provided for employees are provided in such a manner that segregation on the basis of race, color, religion, sex, or national origin cannot result. The contractor may neither require such segregated use by written or oral policies nor tolerate such use by employee custom. The contractor's obligation extends further to ensure that its employees are not assigned to perform their services at any location, under the contractor's control, where the facilities are segregated. The term "facilities" includes waiting rooms, work areas, restaurants and other eating areas, time clocks, restrooms, washrooms, locker rooms, and other storage or dressing areas, parking lots, drinking fountains, recreation or entertainment areas, transportation, and housing provided for employees. The contractor shall provide separate or single-user restrooms and necessary dressing or sleeping areas to assure privacy between sexes.

IV. DAVIS-BACON AND RELATED ACT PROVISIONS

This section is applicable to all Federal-aid construction projects exceeding \$2,000 and to all related subcontracts and lower-tier subcontracts (regardless of subcontract size). The requirements apply to all projects located within the right-of-way of a roadway that is functionally classified as Federal-aid highway. This excludes roadways functionally classified as local roads or rural minor collectors, which are exempt. Contracting agencies may elect to apply these requirements to other projects.

The following provisions are from the U.S. Department of Labor regulations in 29 CFR 5.5 "Contract provisions and related matters" with minor revisions to conform to the FHWA-1273 format and FHWA program requirements.

1. Minimum wages

a. All laborers and mechanics employed or working upon the site of the work, will be paid unconditionally and not less often than once a week, and without subsequent deduction or rebate on any account (except such payroll deductions as are permitted by regulations issued by the Secretary of Labor under the Copeland Act (29 CFR part 3)), the full amount of wages and bona fide fringe benefits (or cash equivalents thereof) due at time of payment computed at rates not less than those contained in the wage determination of the Secretary of Labor which is attached hereto and made a part hereof, regardless of any contractual relationship which may be alleged to exist between the contractor and such laborers and mechanics.

Contributions made or costs reasonably anticipated for bona fide fringe benefits under section 1(b)(2) of the Davis-Bacon Act on behalf of laborers or mechanics are considered wages paid to such laborers or mechanics, subject to the provisions of paragraph 1.d. of this section; also, regular contributions made or costs incurred for more than a weekly period (but not less often than quarterly) under plans, funds, or programs which cover the particular weekly period, are deemed to be constructively made or incurred during such weekly period. Such laborers and mechanics shall be paid the appropriate wage rate and fringe benefits on the wage determination for the classification of work actually performed, without regard to skill, except as provided in 29 CFR 5.5(a)(4). Laborers or mechanics performing work in

more than one classification may be compensated at the rate specified for each classification for the time actually worked therein: Provided, that the employer's payroll records accurately set forth the time spent in each classification in which work is performed. The wage determination (including any additional classification and wage rates conformed under paragraph 1.b. of this section) and the Davis-Bacon poster (WH-1321) shall be posted at all times by the contractor and its subcontractors at the site of the work in a prominent and accessible place where it can be easily seen by the workers.

b. (1) The contracting officer shall require that any class of laborers or mechanics, including helpers, which is not listed in the wage determination and which is to be employed under the contract shall be classified in conformance with the wage determination. The contracting officer shall approve an additional classification and wage rate and fringe benefits therefore only when the following criteria have been met:

(i) The work to be performed by the classification requested is not performed by a classification in the wage determination; and

(ii) The classification is utilized in the area by the construction industry; and

(iii) The proposed wage rate, including any bona fide fringe benefits, bears a reasonable relationship to the wage rates contained in the wage determination.

(2) If the contractor and the laborers and mechanics to be employed in the classification (if known), or their representatives, and the contracting officer agree on the classification and wage rate (including the amount designated for fringe benefits where appropriate), a report of the action taken shall be sent by the contracting officer to the Administrator of the Wage and Hour Division, Employment Standards Administration, U.S. Department of Labor, Washington, DC 20210. The Administrator, or an authorized representative, will approve, modify, or disapprove every additional classification action within 30 days of receipt and so advise the contracting officer or will notify the contracting officer within the 30-day period that additional time is necessary.

(3) In the event the contractor, the laborers or mechanics to be employed in the classification or their representatives, and the contracting officer do not agree on the proposed classification and wage rate (including the amount designated for fringe benefits, where appropriate), the contracting officer shall refer the questions, including the views of all interested parties and the recommendation of the contracting officer, to the Wage and Hour Administrator for determination. The Wage and Hour Administrator, or an authorized representative, will issue a determination within 30 days of receipt and so advise the contracting officer or will notify the contracting officer within the 30-day period that additional time is necessary.

(4) The wage rate (including fringe benefits where appropriate) determined pursuant to paragraphs 1.b.(2) or 1.b.(3) of this section, shall be paid to all workers performing work in the classification under this contract

from the first day on which work is performed in the classification.

c. Whenever the minimum wage rate prescribed in the contract for a class of laborers or mechanics includes a fringe benefit which is not expressed as an hourly rate, the contractor shall either pay the benefit as stated in the wage determination or shall pay another bona fide fringe benefit or an hourly cash equivalent thereof.

d. If the contractor does not make payments to a trustee or other third person, the contractor may consider as part of the wages of any laborer or mechanic the amount of any costs reasonably anticipated in providing bona fide fringe benefits under a plan or program, Provided, That the Secretary of Labor has found, upon the written request of the contractor, that the applicable standards of the Davis-Bacon Act have been met. The Secretary of Labor may require the contractor to set aside in a separate account assets for the meeting of obligations under the plan or program.

2. Withholding

The contracting agency shall upon its own action or upon written request of an authorized representative of the Department of Labor, withhold or cause to be withheld from the contractor under this contract, or any other Federal contract with the same prime contractor, or any other federally-assisted contract subject to Davis-Bacon prevailing wage requirements, which is held by the same prime contractor, so much of the accrued payments or advances as may be considered necessary to pay laborers and mechanics, including apprentices, trainees, and helpers, employed by the contractor or any subcontractor the full amount of wages required by the contract. In the event of failure to pay any laborer or mechanic, including any apprentice, trainee, or helper, employed or working on the site of the work, all or part of the wages required by the contract, the contracting agency may, after written notice to the contractor, take such action as may be necessary to cause the suspension of any further payment, advance, or guarantee of funds until such violations have ceased.

3. Payrolls and basic records

a. Payrolls and basic records relating thereto shall be maintained by the contractor during the course of the work and preserved for a period of three years thereafter for all laborers and mechanics working at the site of the work. Such records shall contain the name, address, and social security number of each such worker, his or her correct classification, hourly rates of wages paid (including rates of contributions or costs anticipated for bona fide fringe benefits or cash equivalents thereof of the types described in section 1(b)(2)(B) of the Davis-Bacon Act), daily and weekly number of hours worked, deductions made and actual wages paid. Whenever the Secretary of Labor has found under 29 CFR 5.5(a)(1)(iv) that the wages of any laborer or mechanic include the amount of any costs reasonably anticipated in providing benefits under a plan or program described in section 1(b)(2)(B) of the Davis-Bacon Act, the contractor shall maintain records which show that the commitment to provide such benefits is enforceable, that the plan or

program is financially responsible, and that the plan or program has been communicated in writing to the laborers or mechanics affected, and records which show the costs anticipated or the actual cost incurred in providing such benefits. Contractors employing apprentices or trainees under approved programs shall maintain written evidence of the registration of apprenticeship programs and certification of trainee programs, the registration of the apprentices and trainees, and the ratios and wage rates prescribed in the applicable programs.

b. (1) The contractor shall submit weekly for each week in which any contract work is performed a copy of all payrolls to the contracting agency. The payrolls submitted shall set out accurately and completely all of the information required to be maintained under 29 CFR 5.5(a)(3)(i), except that full social security numbers and home addresses shall not be included on weekly transmittals. Instead the payrolls shall only need to include an individually identifying number for each employee (e.g., the last four digits of the employee's social security number). The required weekly payroll information may be submitted in any form desired. Optional Form WH-347 is available for this purpose from the Wage and Hour Division Web site at <http://www.dol.gov/esa/whd/forms/wh347instr.htm> or its successor site. The prime contractor is responsible for the submission of copies of payrolls by all subcontractors. Contractors and subcontractors shall maintain the full social security number and current address of each covered worker, and shall provide them upon request to the contracting agency for transmission to the State DOT, the FHWA or the Wage and Hour Division of the Department of Labor for purposes of an investigation or audit of compliance with prevailing wage requirements. It is not a violation of this section for a prime contractor to require a subcontractor to provide addresses and social security numbers to the prime contractor for its own records, without weekly submission to the contracting agency..

(2) Each payroll submitted shall be accompanied by a "Statement of Compliance," signed by the contractor or subcontractor or his or her agent who pays or supervises the payment of the persons employed under the contract and shall certify the following:

(i) That the payroll for the payroll period contains the information required to be provided under §5.5 (a)(3)(ii) of Regulations, 29 CFR part 5, the appropriate information is being maintained under §5.5 (a)(3)(i) of Regulations, 29 CFR part 5, and that such information is correct and complete;

(ii) That each laborer or mechanic (including each helper, apprentice, and trainee) employed on the contract during the payroll period has been paid the full weekly wages earned, without rebate, either directly or indirectly, and that no deductions have been made either directly or indirectly from the full wages earned, other than permissible deductions as set forth in Regulations, 29 CFR part 3;

(iii) That each laborer or mechanic has been paid not less than the applicable wage rates and fringe benefits or cash equivalents for the classification of work performed, as specified in the applicable wage determination incorporated into the contract.

(3) The weekly submission of a properly executed certification set forth on the reverse side of Optional Form WH-347 shall satisfy the requirement for submission of the "Statement of Compliance" required by paragraph 3.b.(2) of this section.

(4) The falsification of any of the above certifications may subject the contractor or subcontractor to civil or criminal prosecution under section 1001 of title 18 and section 231 of title 31 of the United States Code.

c. The contractor or subcontractor shall make the records required under paragraph 3.a. of this section available for inspection, copying, or transcription by authorized representatives of the contracting agency, the State DOT, the FHWA, or the Department of Labor, and shall permit such representatives to interview employees during working hours on the job. If the contractor or subcontractor fails to submit the required records or to make them available, the FHWA may, after written notice to the contractor, the contracting agency or the State DOT, take such action as may be necessary to cause the suspension of any further payment, advance, or guarantee of funds. Furthermore, failure to submit the required records upon request or to make such records available may be grounds for debarment action pursuant to 29 CFR 5.12.

4. Apprentices and trainees

a. Apprentices (programs of the USDOL).

Apprentices will be permitted to work at less than the predetermined rate for the work they performed when they are employed pursuant to and individually registered in a bona fide apprenticeship program registered with the U.S. Department of Labor, Employment and Training Administration, Office of Apprenticeship Training, Employer and Labor Services, or with a State Apprenticeship Agency recognized by the Office, or if a person is employed in his or her first 90 days of probationary employment as an apprentice in such an apprenticeship program, who is not individually registered in the program, but who has been certified by the Office of Apprenticeship Training, Employer and Labor Services or a State Apprenticeship Agency (where appropriate) to be eligible for probationary employment as an apprentice.

The allowable ratio of apprentices to journeymen on the job site in any craft classification shall not be greater than the ratio permitted to the contractor as to the entire work force under the registered program. Any worker listed on a payroll at an apprentice wage rate, who is not registered or otherwise employed as stated above, shall be paid not less than the applicable wage rate on the wage determination for the classification of work actually performed. In addition, any apprentice performing work on the job site in excess of the ratio permitted under the registered program shall be paid not less than the applicable wage rate on the wage determination for the work actually performed. Where a contractor is performing construction on a project in a locality other than that in which its program is registered, the ratios and wage rates (expressed in percentages of the journeyman's hourly rate) specified in the contractor's or subcontractor's registered program shall be observed.

1/8/2020 Revision

Every apprentice must be paid at not less than the rate specified in the registered program for the apprentice's level of progress, expressed as a percentage of the journeymen hourly rate specified in the applicable wage determination. Apprentices shall be paid fringe benefits in accordance with the provisions of the apprenticeship program. If the apprenticeship program does not specify fringe benefits, apprentices must be paid the full amount of fringe benefits listed on the wage determination for the applicable classification. If the Administrator determines that a different practice prevails for the applicable apprentice classification, fringes shall be paid in accordance with that determination.

In the event the Office of Apprenticeship Training, Employer and Labor Services, or a State Apprenticeship Agency recognized by the Office, withdraws approval of an apprenticeship program, the contractor will no longer be permitted to utilize apprentices at less than the applicable predetermined rate for the work performed until an acceptable program is approved.

b. Trainees (programs of the USDOL).

Except as provided in 29 CFR 5.16, trainees will not be permitted to work at less than the predetermined rate for the work performed unless they are employed pursuant to and individually registered in a program which has received prior approval, evidenced by formal certification by the U.S. Department of Labor, Employment and Training Administration.

The ratio of trainees to journeymen on the job site shall not be greater than permitted under the plan approved by the Employment and Training Administration.

Every trainee must be paid at not less than the rate specified in the approved program for the trainee's level of progress, expressed as a percentage of the journeyman hourly rate specified in the applicable wage determination. Trainees shall be paid fringe benefits in accordance with the provisions of the trainee program. If the trainee program does not mention fringe benefits, trainees shall be paid the full amount of fringe benefits listed on the wage determination unless the Administrator of the Wage and Hour Division determines that there is an apprenticeship program associated with the corresponding journeyman wage rate on the wage determination which provides for less than full fringe benefits for apprentices. Any employee listed on the payroll at a trainee rate who is not registered and participating in a training plan approved by the Employment and Training Administration shall be paid not less than the applicable wage rate on the wage determination for the classification of work actually performed. In addition, any trainee performing work on the job site in excess of the ratio permitted under the registered program shall be paid not less than the applicable wage rate on the wage determination for the work actually performed.

In the event the Employment and Training Administration withdraws approval of a training program, the contractor will no longer be permitted to utilize trainees at less than the applicable predetermined rate for the work performed until an acceptable program is approved.

c. Equal employment opportunity. The utilization of apprentices, trainees and journeymen under this part shall be in conformity with the equal employment opportunity requirements of Executive Order 11246, as amended, and 29 CFR part 30.

d. Apprentices and Trainees (programs of the U.S. DOT).

Apprentices and trainees working under apprenticeship and skill training programs which have been certified by the Secretary of Transportation as promoting EEO in connection with Federal-aid highway construction programs are not subject to the requirements of paragraph 4 of this Section IV. The straight time hourly wage rates for apprentices and trainees under such programs will be established by the particular programs. The ratio of apprentices and trainees to journeymen shall not be greater than permitted by the terms of the particular program.

5. Compliance with Copeland Act requirements. The contractor shall comply with the requirements of 29 CFR part 3, which are incorporated by reference in this contract.

6. Subcontracts. The contractor or subcontractor shall insert Form FHWA-1273 in any subcontracts and also require the subcontractors to include Form FHWA-1273 in any lower tier subcontracts. The prime contractor shall be responsible for the compliance by any subcontractor or lower tier subcontractor with all the contract clauses in 29 CFR 5.5.

7. Contract termination: debarment. A breach of the contract clauses in 29 CFR 5.5 may be grounds for termination of the contract, and for debarment as a contractor and a subcontractor as provided in 29 CFR 5.12.

8. Compliance with Davis-Bacon and Related Act requirements. All rulings and interpretations of the Davis-Bacon and Related Acts contained in 29 CFR parts 1, 3, and 5 are herein incorporated by reference in this contract.

9. Disputes concerning labor standards. Disputes arising out of the labor standards provisions of this contract shall not be subject to the general disputes clause of this contract. Such disputes shall be resolved in accordance with the procedures of the Department of Labor set forth in 29 CFR parts 5, 6, and 7. Disputes within the meaning of this clause include disputes between the contractor (or any of its subcontractors) and the contracting agency, the U.S. Department of Labor, or the employees or their representatives.

10. Certification of eligibility.

a. By entering into this contract, the contractor certifies that neither it (nor he or she) nor any person or firm who has an interest in the contractor's firm is a person or firm ineligible to be awarded Government contracts by virtue of section 3(a) of the Davis-Bacon Act or 29 CFR 5.12(a)(1).

b. No part of this contract shall be subcontracted to any person or firm ineligible for award of a Government contract by virtue of section 3(a) of the Davis-Bacon Act or 29 CFR 5.12(a)(1).

c. The penalty for making false statements is prescribed in the U.S. Criminal Code, 18 U.S.C. 1001.

V. CONTRACT WORK HOURS AND SAFETY STANDARDS ACT

The following clauses apply to any Federal-aid construction contract in an amount in excess of \$100,000 and subject to the overtime provisions of the Contract Work Hours and Safety Standards Act. These clauses shall be inserted in addition to the clauses required by 29 CFR 5.5(a) or 29 CFR 4.6. As used in this paragraph, the terms laborers and mechanics include watchmen and guards.

1. Overtime requirements. No contractor or subcontractor contracting for any part of the contract work which may require or involve the employment of laborers or mechanics shall require or permit any such laborer or mechanic in any workweek in which he or she is employed on such work to work in excess of forty hours in such workweek unless such laborer or mechanic receives compensation at a rate not less than one and one-half times the basic rate of pay for all hours worked in excess of forty hours in such workweek.

2. Violation; liability for unpaid wages; liquidated damages. In the event of any violation of the clause set forth in paragraph (1.) of this section, the contractor and any subcontractor responsible therefor shall be liable for the unpaid wages. In addition, such contractor and subcontractor shall be liable to the United States (in the case of work done under contract for the District of Columbia or a territory, to such District or to such territory), for liquidated damages. Such liquidated damages shall be computed with respect to each individual laborer or mechanic, including watchmen and guards, employed in violation of the clause set forth in paragraph (1.) of this section, in the sum of \$10 for each calendar day on which such individual was required or permitted to work in excess of the standard workweek of forty hours without payment of the overtime wages required by the clause set forth in paragraph (1.) of this section.

3. Withholding for unpaid wages and liquidated damages. The FHWA or the contracting agency shall upon its own action or upon written request of an authorized representative of the Department of Labor withhold or cause to be withheld, from any moneys payable on account of work performed by the contractor or subcontractor under any such contract or any other Federal contract with the same prime contractor, or any other federally-assisted contract subject to the Contract Work Hours and Safety Standards Act, which is held by the same prime contractor, such sums as may be determined to be necessary to satisfy any liabilities of such contractor or subcontractor for unpaid wages and liquidated damages as provided in the clause set forth in paragraph (2.) of this section.

4. Subcontracts. The contractor or subcontractor shall insert in any subcontracts the clauses set forth in paragraph (1.) through (4.) of this section and also a clause requiring the subcontractors to include these clauses in any lower tier subcontracts. The prime contractor shall be responsible for compliance by any subcontractor or lower tier subcontractor with the clauses set forth in paragraphs (1.) through (4.) of this section.

VI. SUBLETTING OR ASSIGNING THE CONTRACT

This provision is applicable to all Federal-aid construction contracts on the National Highway System.

1. The contractor shall perform with its own organization contract work amounting to not less than 30 percent (or a greater percentage if specified elsewhere in the contract) of the total original contract price, excluding any specialty items designated by the contracting agency. Specialty items may be performed by subcontract and the amount of any such specialty items performed may be deducted from the total original contract price before computing the amount of work required to be performed by the contractor's own organization (23 CFR 635.116).

a. The term "perform work with its own organization" refers to workers employed or leased by the prime contractor, and equipment owned or rented by the prime contractor, with or without operators. Such term does not include employees or equipment of a subcontractor or lower tier subcontractor, agents of the prime contractor, or any other assignees. The term may include payments for the costs of hiring leased employees from an employee leasing firm meeting all relevant Federal and State regulatory requirements. Leased employees may only be included in this term if the prime contractor meets all of the following conditions:

(1) The prime contractor maintains control over the supervision of the day-to-day activities of the leased employees;

(2) The prime contractor remains responsible for the quality of the work of the leased employees;

(3) The prime contractor retains all power to accept or exclude individual employees from work on the project; and

(4) The prime contractor remains ultimately responsible for the payment of predetermined minimum wages, the submission of payrolls, statements of compliance and all other Federal regulatory requirements.

b. "Specialty Items" shall be construed to be limited to work that requires highly specialized knowledge, abilities, or equipment not ordinarily available in the type of contracting organizations qualified and expected to bid or propose on the contract as a whole and in general are to be limited to minor components of the overall contract.

2. The contract amount upon which the requirements set forth in paragraph (1) of Section VI is computed includes the cost of material and manufactured products which are to be purchased or produced by the contractor under the contract provisions.

3. The contractor shall furnish (a) a competent superintendent or supervisor who is employed by the firm, has full authority to direct performance of the work in accordance with the contract requirements, and is in charge of all construction operations (regardless of who performs the work) and (b) such other of its own organizational resources (supervision, management, and engineering services) as the contracting officer determines is necessary to assure the performance of the contract.

4. No portion of the contract shall be sublet, assigned or otherwise disposed of except with the written consent of the contracting officer, or authorized representative, and such consent when given shall not be construed to relieve the

contractor of any responsibility for the fulfillment of the contract. Written consent will be given only after the contracting agency has assured that each subcontract is evidenced in writing and that it contains all pertinent provisions and requirements of the prime contract.

5. The 30% self-performance requirement of paragraph (1) is not applicable to design-build contracts; however, contracting agencies may establish their own self-performance requirements.

VII. SAFETY: ACCIDENT PREVENTION

This provision is applicable to all Federal-aid construction contracts and to all related subcontracts.

1. In the performance of this contract the contractor shall comply with all applicable Federal, State, and local laws governing safety, health, and sanitation (23 CFR 635). The contractor shall provide all safeguards, safety devices and protective equipment and take any other needed actions as it determines, or as the contracting officer may determine, to be reasonably necessary to protect the life and health of employees on the job and the safety of the public and to protect property in connection with the performance of the work covered by the contract.

2. It is a condition of this contract, and shall be made a condition of each subcontract, which the contractor enters into pursuant to this contract, that the contractor and any subcontractor shall not permit any employee, in performance of the contract, to work in surroundings or under conditions which are unsanitary, hazardous or dangerous to his/her health or safety, as determined under construction safety and health standards (29 CFR 1926) promulgated by the Secretary of Labor, in accordance with Section 107 of the Contract Work Hours and Safety Standards Act (40 U.S.C. 3704).

3. Pursuant to 29 CFR 1926.3, it is a condition of this contract that the Secretary of Labor or authorized representative thereof, shall have right of entry to any site of contract performance to inspect or investigate the matter of compliance with the construction safety and health standards and to carry out the duties of the Secretary under Section 107 of the Contract Work Hours and Safety Standards Act (40 U.S.C.3704).

VIII. FALSE STATEMENTS CONCERNING HIGHWAY PROJECTS

This provision is applicable to all Federal-aid construction contracts and to all related subcontracts.

In order to assure high quality and durable construction in conformity with approved plans and specifications and a high degree of reliability on statements and representations made by engineers, contractors, suppliers, and workers on Federal-aid highway projects, it is essential that all persons concerned with the project perform their functions as carefully, thoroughly, and honestly as possible. Willful falsification, distortion, or misrepresentation with respect to any facts related to the project is a violation of Federal law. To prevent any misunderstanding regarding the seriousness of these and similar acts, Form FHWA-1022 shall be posted on each Federal-aid highway project (23 CFR 635) in one or

more places where it is readily available to all persons concerned with the project:

18 U.S.C. 1020 reads as follows:

"Whoever, being an officer, agent, or employee of the United States, or of any State or Territory, or whoever, whether a person, association, firm, or corporation, knowingly makes any false statement, false representation, or false report as to the character, quality, quantity, or cost of the material used or to be used, or the quantity or quality of the work performed or to be performed, or the cost thereof in connection with the submission of plans, maps, specifications, contracts, or costs of construction on any highway or related project submitted for approval to the Secretary of Transportation; or

Whoever knowingly makes any false statement, false representation, false report or false claim with respect to the character, quality, quantity, or cost of any work performed or to be performed, or materials furnished or to be furnished, in connection with the construction of any highway or related project approved by the Secretary of Transportation; or

Whoever knowingly makes any false statement or false representation as to material fact in any statement, certificate, or report submitted pursuant to provisions of the Federal-aid Roads Act approved July 1, 1916, (39 Stat. 355), as amended and supplemented;

Shall be fined under this title or imprisoned not more than 5 years or both."

IX. IMPLEMENTATION OF CLEAN AIR ACT AND FEDERAL WATER POLLUTION CONTROL ACT

This provision is applicable to all Federal-aid construction contracts and to all related subcontracts.

By submission of this bid/proposal or the execution of this contract, or subcontract, as appropriate, the bidder, proposer, Federal-aid construction contractor, or subcontractor, as appropriate, will be deemed to have stipulated as follows:

1. That any person who is or will be utilized in the performance of this contract is not prohibited from receiving an award due to a violation of Section 508 of the Clean Water Act or Section 306 of the Clean Air Act.

2. That the contractor agrees to include or cause to be included the requirements of paragraph (1) of this Section X in every subcontract, and further agrees to take such action as the contracting agency may direct as a means of enforcing such requirements.

X. CERTIFICATION REGARDING DEBARMENT, SUSPENSION, INELIGIBILITY AND VOLUNTARY EXCLUSION

This provision is applicable to all Federal-aid construction contracts, design-build contracts, subcontracts, lower-tier subcontracts, purchase orders, lease agreements, consultant contracts or any other covered transaction requiring FHWA approval or that is estimated to cost \$25,000 or more – as defined in 2 CFR Parts 180 and 1200.

lower tier covered transactions exceeding the \$25,000 threshold.

1. Instructions for Certification – First Tier Participants:

a. By signing and submitting this proposal, the prospective first tier participant is providing the certification set out below.

b. The inability of a person to provide the certification set out below will not necessarily result in denial of participation in this covered transaction. The prospective first tier participant shall submit an explanation of why it cannot provide the certification set out below. The certification or explanation will be considered in connection with the department or agency's determination whether to enter into this transaction. However, failure of the prospective first tier participant to furnish a certification or an explanation shall disqualify such a person from participation in this transaction.

c. The certification in this clause is a material representation of fact upon which reliance was placed when the contracting agency determined to enter into this transaction. If it is later determined that the prospective participant knowingly rendered an erroneous certification, in addition to other remedies available to the Federal Government, the contracting agency may terminate this transaction for cause of default.

d. The prospective first tier participant shall provide immediate written notice to the contracting agency to whom this proposal is submitted if any time the prospective first tier participant learns that its certification was erroneous when submitted or has become erroneous by reason of changed circumstances.

e. The terms "covered transaction," "debarred," "suspended," "ineligible," "participant," "person," "principal," and "voluntarily excluded," as used in this clause, are defined in 2 CFR Parts 180 and 1200. "First Tier Covered Transactions" refers to any covered transaction between a grantee or subgrantee of Federal funds and a participant (such as the prime or general contract). "Lower Tier Covered Transactions" refers to any covered transaction under a First Tier Covered Transaction (such as subcontracts). "First Tier Participant" refers to the participant who has entered into a covered transaction with a grantee or subgrantee of Federal funds (such as the prime or general contractor). "Lower Tier Participant" refers any participant who has entered into a covered transaction with a First Tier Participant or other Lower Tier Participants (such as subcontractors and suppliers).

f. The prospective first tier participant agrees by submitting this proposal that, should the proposed covered transaction be entered into, it shall not knowingly enter into any lower tier covered transaction with a person who is debarred, suspended, declared ineligible, or voluntarily excluded from participation in this covered transaction, unless authorized by the department or agency entering into this transaction.

g. The prospective first tier participant further agrees by submitting this proposal that it will include the clause titled "Certification Regarding Debarment, Suspension, Ineligibility and Voluntary Exclusion-Lower Tier Covered Transactions," provided by the department or contracting agency, entering into this covered transaction, without modification, in all lower tier covered transactions and in all solicitations for

h. A participant in a covered transaction may rely upon a certification of a prospective participant in a lower tier covered transaction that is not debarred, suspended, ineligible, or voluntarily excluded from the covered transaction, unless it knows that the certification is erroneous. A participant is responsible for ensuring that its principals are not suspended, debarred, or otherwise ineligible to participate in covered transactions. To verify the eligibility of its principals, as well as the eligibility of any lower tier prospective participants, each participant may, but is not required to, check the Excluded Parties List System website (<https://www.epls.gov/>), which is compiled by the General Services Administration.

i. Nothing contained in the foregoing shall be construed to require the establishment of a system of records in order to render in good faith the certification required by this clause. The knowledge and information of the prospective participant is not required to exceed that which is normally possessed by a prudent person in the ordinary course of business dealings.

j. Except for transactions authorized under paragraph (f) of these instructions, if a participant in a covered transaction knowingly enters into a lower tier covered transaction with a person who is suspended, debarred, ineligible, or voluntarily excluded from participation in this transaction, in addition to other remedies available to the Federal Government, the department or agency may terminate this transaction for cause or default.

2. Certification Regarding Debarment, Suspension, Ineligibility and Voluntary Exclusion – First Tier Participants:

a. The prospective first tier participant certifies to the best of its knowledge and belief, that it and its principals:

(1) Are not presently debarred, suspended, proposed for debarment, declared ineligible, or voluntarily excluded from participating in covered transactions by any Federal department or agency;

(2) Have not within a three-year period preceding this proposal been convicted of or had a civil judgment rendered against them for commission of fraud or a criminal offense in connection with obtaining, attempting to obtain, or performing a public (Federal, State or local) transaction or contract under a public transaction; violation of Federal or State antitrust statutes or commission of embezzlement, theft, forgery, bribery, falsification or destruction of records, making false statements, or receiving stolen property;

(3) Are not presently indicted for or otherwise criminally or civilly charged by a governmental entity (Federal, State or local) with commission of any of the offenses enumerated in paragraph (a)(2) of this certification; and

(4) Have not within a three-year period preceding this application/proposal had one or more public transactions (Federal, State or local) terminated for cause or default.

b. Where the prospective participant is unable to certify to any of the statements in this certification, such prospective participant shall attach an explanation to this proposal.

2. Instructions for Certification - Lower Tier Participants:

(Applicable to all subcontracts, purchase orders and other lower tier transactions requiring prior FHWA approval or estimated to cost \$25,000 or more - 2 CFR Parts 180 and 1200)

a. By signing and submitting this proposal, the prospective lower tier is providing the certification set out below.

b. The certification in this clause is a material representation of fact upon which reliance was placed when this transaction was entered into. If it is later determined that the prospective lower tier participant knowingly rendered an erroneous certification, in addition to other remedies available to the Federal Government, the department, or agency with which this transaction originated may pursue available remedies, including suspension and/or debarment.

c. The prospective lower tier participant shall provide immediate written notice to the person to which this proposal is submitted if at any time the prospective lower tier participant learns that its certification was erroneous by reason of changed circumstances.

d. The terms "covered transaction," "debarred," "suspended," "ineligible," "participant," "person," "principal," and "voluntarily excluded," as used in this clause, are defined in 2 CFR Parts 180 and 1200. You may contact the person to which this proposal is submitted for assistance in obtaining a copy of those regulations. "First Tier Covered Transactions" refers to any covered transaction between a grantee or subgrantee of Federal funds and a participant (such as the prime or general contract). "Lower Tier Covered Transactions" refers to any covered transaction under a First Tier Covered Transaction (such as subcontracts). "First Tier Participant" refers to the participant who has entered into a covered transaction with a grantee or subgrantee of Federal funds (such as the prime or general contractor). "Lower Tier Participant" refers any participant who has entered into a covered transaction with a First Tier Participant or other Lower Tier Participants (such as subcontractors and suppliers).

e. The prospective lower tier participant agrees by submitting this proposal that, should the proposed covered transaction be entered into, it shall not knowingly enter into any lower tier covered transaction with a person who is debarred, suspended, declared ineligible, or voluntarily excluded from participation in this covered transaction, unless authorized by the department or agency with which this transaction originated.

f. The prospective lower tier participant further agrees by submitting this proposal that it will include this clause titled "Certification Regarding Debarment, Suspension, Ineligibility and Voluntary Exclusion-Lower Tier Covered Transaction," without modification, in all lower tier covered transactions and in all solicitations for lower tier covered transactions exceeding the \$25,000 threshold.

g. A participant in a covered transaction may rely upon a certification of a prospective participant in a lower tier covered transaction that is not debarred, suspended,

ineligible, or voluntarily excluded from the covered transaction, unless it knows that the certification is erroneous. A participant is responsible for ensuring that its principals are not suspended, debarred, or otherwise ineligible to participate in covered transactions. To verify the eligibility of its principals, as well as the eligibility of any lower tier prospective participants, each participant may, but is not required to, check the Excluded Parties List System website (<https://www.epls.gov/>), which is compiled by the General Services Administration.

h. Nothing contained in the foregoing shall be construed to require establishment of a system of records in order to render in good faith the certification required by this clause. The knowledge and information of participant is not required to exceed that which is normally possessed by a prudent person in the ordinary course of business dealings.

i. Except for transactions authorized under paragraph e of these instructions, if a participant in a covered transaction knowingly enters into a lower tier covered transaction with a person who is suspended, debarred, ineligible, or voluntarily excluded from participation in this transaction, in addition to other remedies available to the Federal Government, the department or agency with which this transaction originated may pursue available remedies, including suspension and/or debarment.

Certification Regarding Debarment, Suspension, Ineligibility and Voluntary Exclusion--Lower Tier Participants:

1. The prospective lower tier participant certifies, by submission of this proposal, that neither it nor its principals is presently debarred, suspended, proposed for debarment, declared ineligible, or voluntarily excluded from participating in covered transactions by any Federal department or agency.

2. Where the prospective lower tier participant is unable to certify to any of the statements in this certification, such prospective participant shall attach an explanation to this proposal.

XI. CERTIFICATION REGARDING USE OF CONTRACT FUNDS FOR LOBBYING

This provision is applicable to all Federal-aid construction contracts and to all related subcontracts which exceed \$100,000 (49 CFR 20).

1. The prospective participant certifies, by signing and submitting this bid or proposal, to the best of his or her knowledge and belief, that:

a. No Federal appropriated funds have been paid or will be paid, by or on behalf of the undersigned, to any person for influencing or attempting to influence an officer or employee of any Federal agency, a Member of Congress, an officer or employee of Congress, or an employee of a Member of Congress in connection with the awarding of any Federal contract, the making of any Federal grant, the making of any Federal loan, the entering into of any cooperative agreement, and the extension, continuation,

1/8/2020 Revision

renewal, amendment, or modification of any Federal contract, grant, loan, or cooperative agreement.

b. If any funds other than Federal appropriated funds have been paid or will be paid to any person for influencing or attempting to influence an officer or employee of any Federal agency, a Member of Congress, an officer or employee of Congress, or an employee of a Member of Congress in connection with this Federal contract, grant, loan, or cooperative agreement, the undersigned shall complete and submit Standard Form-LLL, "Disclosure Form to Report Lobbying," in accordance with its instructions.

2. This certification is a material representation of fact upon which reliance was placed when this transaction was made or entered into. Submission of this certification is a prerequisite for making or entering into this transaction imposed by 31 U.S.C. 1352. Any person who fails to file the required certification shall be subject to a civil penalty of not less than \$10,000 and not more than \$100,000 for each such failure.

3. The prospective participant also agrees by submitting its bid or proposal that the participant shall require that the language of this certification be included in all lower tier subcontracts, which exceed \$100,000 and that all such recipients shall certify and disclose accordingly.

ATTACHMENT A - EMPLOYMENT AND MATERIALS PREFERENCE FOR APPALACHIAN DEVELOPMENT HIGHWAY SYSTEM OR APPALACHIAN LOCAL ACCESS ROAD CONTRACTS

This provision is applicable to all Federal-aid projects funded under the Appalachian Regional Development Act of 1965.

1. During the performance of this contract, the contractor undertaking to do work which is, or reasonably may be, done as on-site work, shall give preference to qualified persons who regularly reside in the labor area as designated by the DOL wherein the contract work is situated, or the subregion, or the Appalachian counties of the State wherein the contract work is situated, except:

a. To the extent that qualified persons regularly residing in the area are not available.

b. For the reasonable needs of the contractor to employ supervisory or specially experienced personnel necessary to assure an efficient execution of the contract work.

c. For the obligation of the contractor to offer employment to present or former employees as the result of a lawful collective bargaining contract, provided that the number of nonresident persons employed under this subparagraph (1c) shall not exceed 20 percent of the total number of employees employed by the contractor on the contract work, except as provided in subparagraph (4) below.

2. The contractor shall place a job order with the State Employment Service indicating (a) the classifications of the laborers, mechanics and other employees required to perform the contract work, (b) the number of employees required in each classification, (c) the date on which the participant estimates such employees will be required, and

(d) any other pertinent information required by the State Employment Service to complete the job order form. The job order may be placed with the State Employment Service in writing or by telephone. If during the course of the contract work, the information submitted by the contractor in the original job order is substantially modified, the participant shall promptly notify the State Employment Service.

3. The contractor shall give full consideration to all qualified job applicants referred to him by the State Employment Service. The contractor is not required to grant employment to any job applicants who, in his opinion, are not qualified to perform the classification of work required.

4. If, within one week following the placing of a job order by the contractor with the State Employment Service, the State Employment Service is unable to refer any qualified job applicants to the contractor, or less than the number requested, the State Employment Service will forward a certificate to the contractor indicating the unavailability of applicants. Such certificate shall be made a part of the contractor's permanent project records. Upon receipt of this certificate, the contractor may employ persons who do not normally reside in the labor area to fill positions covered by the certificate, notwithstanding the provisions of subparagraph (1c) above.

5. The provisions of 23 CFR 633.207(e) allow the contracting agency to provide a contractual preference for the use of mineral resource materials native to the Appalachian region.

6. The contractor shall include the provisions of Sections 1 through 4 of this Attachment A in every subcontract for work which is, or reasonably may be, done as on-site work.

Appendix A

Checklist for Bidders- Federally Funded Projects with a DBE Goal

- Quotes have been obtained by DBE firms for participation on the project
- NAICS codes have been verified on the Ohio Unified DBE Directory that the DBE firms to be utilized can be applied toward the project goal for the specific work wanted:
<http://www.dot.state.oh.us/Divisions/ODI/SDBE/Pages/DBE-Directory.aspx>
- DBE Utilization Plan has been completed & submitted electronically prior to bid opening via: https://odot.formstack.com/forms/dbe_copy (This applies to all Bidders including DBE Firms)
- The Utilization Plan submitted as described above, meets or exceeds the DBE Goal established for the project
- If the DBE Goal has not been met that Good Faith Efforts have been submitted prior to bid to opening to: Dot.contractslettingmgr@dot.ohio.gov
- The affirmation form that is required 5 calendar days after bid opening has been downloaded ready to send out to all DBE firms listed on the Utilization Plan:
<http://Transportation.ohio.gov/Divisions/ODI/SDBE/Pages/Resources.aspx>.

SECTION V

Bid Proposal and Bid Guaranty

BIDDER'S CHECKLIST

**ODOT PID 109613: WAR-CR21-0.23-0.41,
(aka Mason-Montgomery Rd Access Management Project)
DEERFIELD TWP
WARREN COUNTY, OHIO**

Required Submittals

- Non-Collusion Affidavit
- Affidavit Affirming Compliance with 9.24 and 5719.042 O.R.C.
- Affidavit Affirming Compliance with 3517.13 O.R.C.
- Bid Proposal, including Bid Proposal Unit Cost spreadsheet
- Complete Section IV (Federal and State Requirements), Page 3, Item #6-Federally Required EEO Certification.
- Addenda (if applies)

Bid Guaranty

(Select only one)

- Certified Check (10% of Bid)
- Cashier's Check (10% of Bid)
- Irrevocable letter of Credit (10% of Bid)
- Bid Guaranty and Contract Bond, Combination (100% of Bid)

If Using Bid Guaranty and Contract Bond

- Signed by Bidder & Surety Agent
- Power of Attorney – Proper Agent Name and Date
- Current Financial Statement of Surety
- Current Certificate of Insurance for Surety from Department of Insurance

Additional Reminders

- Reviewed Proposal and worksheets for mathematical errors

This checklist is not intended to relieve the bidder of the responsibility to provide other required documents. Rather, this checklist is offered merely to serve as an aid in assisting in the preparation of the bid. Notice is hereby given that the failure to submit all required documents duly and properly constituted including but not limited to all required signatures may result in the rejection of your bid on the basis that the bid is non-responsive.

WAR-CR21 0.23-0.41 MASON-MONTGOMERY RD ACCESS MANAGEMENT PROJECT
 ODOT PID 109613

Ref No.	Item No.	Ext. No.	Item Description	Quantity	Unit	Unit Price	Total Cost
Pavement							
1	254	E01000	Pavement Planing, Asphalt Concrete	7418	SY		
2	407	E20000	Non-Tracking Tack Coat	641	GAL		
3	609	E72000	Concrete Median	295	SY		
4	442	E100000	Asphalt Concrete Surface Course, 12/5 MM, Type A (446)	395	CY		
Pavement Subtotal							
Traffic Control							
5	620	E60000	Delineator, Post Surface Mounted	35	EACH		
6	621	E00100	RPM	77	EACH		
7	621	E54000	Raised Pavement Marker Removed	77	EACH		
8	630	E03100	Ground Mounted Support, No 3 Post	130	FT		
9	630	E08600	Sign Post Reflector	2	EACH		
10	630	E80100	Sign, Flat Sheet	57	SF		
11	630	E84900	Removal of Ground Mounted Sign and Disposal	7	EACH		
12	630	E86002	Removal of Ground Mounted Post Support and Disposal	5	EACH		
13	642	E01290	Lane Arrow	8	EACH		
14	642	E01390	Word on Pavement, 72"	4	EACH		
15	644	E00204	Lane Line, 6"	0.54	MILE		
16	644	E00300	Center Line	0.29	MILE		
17	644	E00404	Channelizing Line, 12"	372	FT		
18	644	E00500	Stop Line	85	FT		
19	644	E00700	Transverse/Diagonal Line	62	FT		
20	644	E01510	Dotted Line, 6"	23	FT		
21	644	E01520	Dotted Line 12"	109	FT		
Traffic Control Subtotal							
Maintenance of Traffic							
19	614	E11110	Law Enforcement Officer with Patrol Car for Assistance	200	Hour		
20	614	E20200	Work Zone Lane Line, Class I, 4", 740.06, Type 1	0.57	MILE		
21	614	E21200	Work Zone Center Line, Class I, 740.06, Type I	0.29	MILE		
22	614	E23400	Work Zone Channelizing Line, Class I, 8" 740.06, Type I	379	FT		
23	614	E26400	Work Zone Stop Line, Class I, 740.06, Type I	85	EACH		
24	614	E30400	Work Zone Arrow, Class I, 740.06, Type I	6	EACH		
25	614	E31400	Work Zone Work on Pavement, 72", Class I, 740.06, Type I	6	EACH		
Maintenance of Traffic Subtotal							
Incidentals							
25	614	E11000	Maintaning Traffic	1	LS		
26	623	E100000	Construction Layout Stakes and Surveying	1	LS		
27	624	E100000	Mobilization	1	LS		

WAR-CR21 0.23-0.41 MASON-MONTGOMERY RD ACCESS MANAGEMENT PROJECT
 ODOT PID 109613

Ref No.	Item No.	Ext. No.	Item Description	Quantity	Unit	Unit Price	Total Cost
Incidentals Subtotal							
Total Bid Amount							

BID PROPOSAL

**ODOT PID 109613: WAR-CR21-0.23-0.41,
(aka Mason-Montgomery Rd Access Management Project)
DEERFIELD TWP
WARREN COUNTY, OHIO**

TO THE WARREN COUNTY TRANSPORTATION IMPROVEMENT DISTRICT :

The undersigned certifies that he/she has examined the plans and specifications and has inspected the site of the proposed improvements. It is understood that the following bid will be governed by the UNIT PRICE BID, unless otherwise specified, also that the quantities may be increased or decreased, if the bid is a unit price bid.

The undersigned submits with the following bid a bid guarantee for the amount, as set forth in Section 200.5 of the General Provisions, and proposes to furnish all labor, equipment, and materials necessary for the construction of **ODOT PID 109613: WAR-CR21-0.23-0.41, (aka Mason-Montgomery Rd Access Management Project)**, in accordance with the Ohio Department of Transportation Construction and Material Specifications, Standard Construction Drawings, Ohio Manual of Uniform Traffic Control, The Ohio Department of Transportation Bridge Design manual, and the Technical Specifications contained in the Construction Drawings, under the most current versions of the aforementioned drawings and specifications and in force on the date of letting shall be enforced by the Warren County Transportation Improvement District:

**ODOT PID 109613: WAR-CR21-0.23-0.41,
(aka Mason-Montgomery Rd Access Management Project)
DEERFIELD TWP
WARREN COUNTY, OHIO**

TOTAL ENGINEER'S ESTIMATE:

Two Hundred Thousand Dollars and no cents (\$200,000.00)

Please enter the total cost of the Bid Proposal, OBTAINED FROM THE ATTACHED WORKSHEETS, in the space below:

TOTAL BID AMOUNT: _____

Amount of Guaranty: Each Proposal must be accompanied by a bond in the sum of One Hundred (100) percent (%) of the Bid Amount or a CERTIFIED CHECK, CASHIER'S CHECK, OR IRREVOCABLE LETTER OF CREDIT pursuant to Chapter 1305 of the Ohio Revised Code in the sum of ten (10) percent (%) of the Bid Amount on a solvent bank as a guarantee that if the Proposal is accepted a contract will be entered into.

BID OPENING DATE: **Wednesday, April 21, 2020**
BIDS RECEIVED BY: **9:00 AM. Local Time**

COMPLETION DATE: **All work shall be completed by August 1, 2020.**

The undersigned hereby acknowledges receipt of the following addenda:
Project No. 20-01

Addendum No. _____ Date _____
Addendum No. _____ Date _____
Addendum No. _____ Date _____
Addendum No. _____ Date _____

It is understood that if this bid is accepted, the undersigned will enter into a contract and give bond with approved security in the full amount of the bid within ten (10) days after the award of the contract by the Warren County Transportation Improvement District, otherwise the Bid Guarantee will be forfeited.

Witness our hands this _____ day of _____, 2020

NAME OF BIDDER: _____
(COMPANY OR CORPORATION) (SIGNATURE OF AGENT)

*****Submit all information in duplicate as stated in 400.6 of Section II *******

BID GUARANTY AND CONTRACT BOND

KNOW ALL MEN BY THESE PRESENTS, that we, the undersigned _____ as Principal and _____ as Surety, are hereby held and firmly bound unto The Warren County Transportation Improvement District and the State of Ohio, Department of Transportation, herein after called the Obligee, in the penal sum of the dollar amount of the bid submitted by the Principal to the Obligee, on _____, 20____ to undertake the Project known as:

**ODOT PID 109613: WAR-CR21-0.23-0.41,
(aka Mason-Montgomery Rd Access Management Project)
DEERFIELD TWP
WARREN COUNTY, OHIO**

The penal sum referred to herein shall be the dollar amount of the Principal's bid to the Obligee, incorporating any additive or deductive alternate proposals made by the Principal on the date referred to above to the Obligee, which are accepted by the Obligee. In no case shall the penal sum exceed the amount of _____ dollars (\$_____). (If the above line is left blank, the penal sum will be the full amount of the Principal's bid, including alternates. Alternatively, if completed, the amount stated must not be less than the full amount of the bid, including alternates, in dollars and cents. A percentage is not acceptable.) For the payment of the penal sum well and truly to be made, we hereby jointly and severally bind ourselves, our heirs, executors, administrators, successors, and assigns.

THE CONDITION OF THE ABOVE OBLIGATION IS SUCH, that whereas the above named Principal has submitted a bid on the above referred to project.

NOW, THEREFORE, if the Obligee accepts the bid of the Principal and the Principal fails to enter into a proper contract in accordance with the bid, plans, details, specifications, and bills of material; and in the event the Principal pays to the Obligee the difference not to exceed ten percent to the penalty hereof between the amount specified in the bid and such larger amount for which the Obligee may in good faith contract with the next bidder to perform the work covered by the bid; or in the event the Obligee does not award the Contract to the next most responsive and responsible bidder and resubmits the project for bidding, the Principal will pay the Obligee the difference not to exceed ten percent of the penalty hereof between the amount specified in the bid, or the costs, in connection with the resubmission, of printing new contract documents, required advertising and printing and mailing notices to prospective bidders, whichever is less, then this obligation shall be void, otherwise to remain in full force and effect. If the Obligee accepts the bid of the Principal and the Principal, within ten days after the awarding of the contract, enters into a proper contract in accordance with the bid, plans, details, specifications, and bills of material, which said contract is made a part of this bond the same as though set forth herein; and IF THE SAID Principal shall well and faithfully perform each and every condition of such contract; and indemnify the Warren County Transportation Improvement District against all damage suffered by failure to perform such contract according to the provisions thereof and in accordance with the plans, details, specifications and bills of material, therefore; and shall pay all lawful claims of subcontractors, materialmen, and laborers, for labor performed and materials furnished in the carrying forward, performing, or completing of said contract, we agreeing and assenting that this undertaking shall be for the benefit of any materialman or laborer having a just claim, as well as for the Obligee herein; then this obligation shall be void; otherwise the same shall remain in full force and effect; it being expressly understood and agreed that the liability of the Surety for any and all claim hereunder shall in no event exceed the penal amount of this obligation as herein stated.

THE SAID Surety hereby stipulates and agrees that no modifications, omissions, or additions, in or to the terms of said contract or in or to the plans or specifications therefore shall in any way affect the

obligations of said Surety on this bond, and it does hereby waive notice of any such modifications, omissions or additions to the terms of the contract or to the work or to the specifications.

SIGNED AND SEALED this _____ day of _____, 20_____.

Principal

By: _____
(Seal)

Surety

By: _____
Attorney/Attorney-In-Fact

(SEAL)

Awarding authorities are simultaneously, with notice of award to Contractor, to give written notice to Surety and Agent. Show name and mailing address of both Agent and Surety.

Surety's Address:

Agent's Address:

SECTION VI

***Affidavits
And
Change Order Form***

AFFIDAVIT IN COMPLIANCE WITH SECTION 3517.13
OF THE OHIO REVISED CODE

STATE OF _____ }

}

SS:

COUNTY OF _____ }

Personally appeared before me the undersigned, as an individual or as a representative of _____ for a contract for:
(Name of Entity)

ODOT PID 109613: WAR-CR21-0.23-0.41

to be let by Warren County Transportation Improvement District, who, being duly cautioned and sworn, makes the following statement with respect to prohibited activities constituting a conflict of interest or other violations under Ohio Revised Code Section 3517.13 (campaign contributions and reporting) and further states that the undersigned has the authority to make the following representation on behalf of himself or herself or of the business entity:

1. That none of the following has individually made within the previous twenty-four months and that, if awarded a contract for the purchase of goods or services with a cost aggregating in excess of \$10,000 in a calendar year, none of the following individually will make, beginning on the date the contract is awarded and extending until one year following the conclusion of the contract, as an individual, one or more campaign contributions totaling in excess of \$1,000, to any member of the Warren County Transportation Improvement District or their individual campaign committees, or if the contracting authority is another elected official of Warren County, to that official or their individual campaign committee:

- a. myself;
- b. any partner or owner or shareholder of the partnership (if applicable);
- c. any owner of more than 20% of the corporation or business trust (if applicable);
- d. each spouse of any person identified in (a) through (c) of this section;
- e. each child seven years of age to seventeen years of age of any person identified in divisions (a) through (c) of this section (only applicable to contributions made on or after January 1, 2007).

2. That none of the following have collectively made since January 1, 2007, and that, if awarded a contract for the purchase of goods and services with a cost aggregating in excess of \$10,000 in a calendar year, none of the following collectively will make, beginning on the date the contract is awarded and extending until one year following the conclusion of the contract, one or more campaign contributions totaling in excess of

\$2,000, to any member of the Warren County Transportation Improvement District or their individual campaign committees, or if the contracting authority is another elected official of Warren County, to that official or their individual campaign committee:

- a. myself;
- b. any partner or owner or shareholder of the partnership (if applicable);
- c. any owner of more than 20% of the corporation or business trust (if applicable);
- d. each spouse of any person identified in (a) through (c) of this section;
- e. each child seven years of age to seventeen years of age of any person identified in divisions (a) through (c) of this section.

3. That this representation is made to induce the County to enter into a contractual relationship with the Contractor, and with the knowledge that County officials will rely on the authenticity of statements made herein in awarding and administering such contracts.

Signature _____

Title: _____

Sworn to before me and subscribed in my presence this _____ day
of _____, 20_____.

Notary Public _____

My Commission Expires: _____

**AFFIDAVIT IN COMPLIANCE WITH SECTIONS 9.24 AND 5719.042 OF THE OHIO
REVISED CODE**

WARREN COUNTY, OHIO

**ODOT PID 109613: WAR-CR21-0.23-0.41
(aka Mason-Montgomery Rd Access Management Project)
DEERFIELD TWP
WARREN COUNTY, OHIO**

(PLEASE TYPE OR PRINT NAME OF FIRM)

(AGENT/OWNER FOR FIRM)

personally appeared before me, the undersigned, a Bidder in competitive bidding for a Construction Contract to be let by the Warren County Transportation Improvement District, who, being duly cautioned and sworn, makes the following statement with respect to the personal property taxes on the general tax list of personal property of Warren County, Ohio:

- (1) That the above mentioned firm and its owner/agent at the time of making his/her Bid (Proposal) on the aforementioned Contract was not charged with any delinquent personal property taxes on the general tax list of personal property of Warren County, Ohio.
- (2) That this statement is made in compliance with Section 5719.042 of the Ohio Revised Code to be incorporated into the Contract between the parties as provided in Section 5719.042 of the Ohio Revised Code.
- (3) That pursuant to §9.24 of the Ohio Revised Code, if the project for which this bid is submitted has been identified as being funded in whole or in part with funds from the State of Ohio, the affiant further certifies that the bidder, if an individual, or if a corporation, any principal owning more than 10% equitable interest in the corporation, does not have a finding for recovery issued by the Auditor of State which remains unresolved as defined in §9.24 O.R.C.

(SIGNATURE)

(TITLE/POSITION)

Sworn to me this _____, day of _____, 2020

(NOTARY PUBLIC)

My Commission expires on _____, _____.

(SEAL)

**NON-COLLUSION AFFIDAVIT OF PRIME BIDDER
WARREN COUNTY, OHIO**

ODOT PID 109613: WAR-CR21-0.23-0.41

(PLEASE TYPE OR PRINT FULL NAME)

(TITLE/POSITION)

being duly sworn, do depose and say the following:

1. He/She is _____,
(OWNER/AGENT) (TITLE/POSITION)

the bidder that has submitted the attached Bid or Proposal;
2. He/She is fully informed respecting the preparation and contents of the attached Bid and of all pertinent circumstances respecting such Bid (Proposal);
3. Such Bid (Proposal) is genuine and is not a collusive or sham Bid (Proposal);
4. Neither the said Bidder nor any of its officers, partners, owners, agents, representatives, employees or parties in interest, including this Affidavit, has in any way colluded, conspired, connived or agreed, directly or indirectly with any other bidder, firm or person to submit a collusive or sham Bid (Proposal) in connection with the Contract for which the attached Bid (Proposal) has been submitted or to refrain from bidding in connection with such Contract or has in any manner, directly or indirectly, sought by agreement or collusion or communication or conference with any other Bidder, firm or person, to fix the price or prices in the attached Bid or of any other Bidder or to fix any overhead, profit or cost element of the Bid Price or Bid Price of any other Bidder, or to secure through any collusion, conspiracy, connivance, or unlawful agreement any advantage against the Warren County Transportation Improvement District or any person interested in the proposed Contract;
5. The price or prices quoted in the attached Bid (Proposal) are fair and proper and are not tainted by any collusion, conspiracy, connivance or unlawful agreement on the Part of the Bidder or any of its agents, representatives, owners, employees, or parties in interest, including this Affidavit.

(SIGNATURE)

(TITLE/POSITION)

Sworn to me this _____, day of _____,
202020202020.

(NOTARY PUBLIC)

My Commission expires on _____,
(SEAL)

Buy America Certification

PID: _____ Project Name: _____

Project Description: _____

The undersigned Proposer hereby certifies on behalf of itself and all contractors (at all tiers) that it will meet Buy America requirements in 23 CFR 635.410, using one of the following provisions:

_____ **The product contains no steel or iron products manufactured outside the United States.** To be considered domestic, all steel and iron used and all products manufactured from steel and iron must be produced in the United States and all manufacturing processes, including application of a coating, for these materials must occur in the United States. Coating includes all processes that protect or enhance the value of the material to which the coating is applied. The Buy America process does not apply to this project. If there is ANY foreign steel or iron in your product you may not check this box.

_____ **The product has minimal use of steel or iron products manufactured outside the United States.** The Buy America regulation does “not prevent a minimal use of foreign steel and iron materials, if the cost of such materials used does not exceed one-tenth of one percent (0.1 percent) of the total contract cost or \$2,500, whichever is greater. For purposes of this paragraph, the cost is that shown to be the value of the steel and iron products as they are delivered to the project. If this minimal use clause applies to your project, then please provide documentation indicating that this requirement is being met. The Buy America process does not apply to your project.

_____ **The product meets the standards for the FHWA Manufactured Products waiver.** FHWA policy provides for a Buy America waiver for certain manufactured products. To be eligible for the Manufactured Products waiver, the product must consist of less than 90% steel or iron content when it is delivered to the job site for installation. Please [click here](#) for the full guidance on manufactured products. If your product meets this manufactured products definition, please provide documentation of how the product is a manufactured product and submit to ODOT for approval.

_____ **The product has foreign steel or iron; a Buy America waiver is required.** ODOT may, but is not obligated to, seek a waiver of Buy America requirements if grounds for the waiver exist. However, Proposer certifies that it will comply with the applicable Buy America requirements if a waiver of those requirements is not available or not pursued by the Department. The waiver process can take time and the project may not move forward until a waiver is completed.

A false certification is a criminal act in violation of 18 USC 1001. Should this Agreement be investigated, Proposer has the burden of proof to establish that it is in compliance.

Proposer: _____

Signature of Authorized Official: _____

Name of Authorized Official: _____

Title: _____

Date: _____



Warren County Transportation Improvement District (WCTID) Construction Change Order Form



PROJECT: _____	Contract No.: _____
CONTRACTOR: _____	Change Order No: _____

The terms and conditions of the above-referenced Contract shall govern this Change Order. This Change Order is mutually agreed to amend the above-referenced Contract, effective as of _____, as follows:

The Contract Sum will be adjusted as follows, and any payments made to Contractor hereunder will be paid according to the terms of the Contract. The change, if any, in the Contract Price shall be computed according to one of the following methods (select as appropriate):

- 1. No Change
- 2. Lump Sum of \$ _____
- 3. Unit Price GMP _____
- 4. Other (Describe) _____

The Contract Time will be increased by _____ (____) Calendar Days. If left blank, this shall be considered a zero time extension Change Order.

By signing below, Contractor acknowledges that this Change Order is a full and final settlement of all claims against Warren County, the Warren County Transportation Improvement District, the Engineer or Architect, and their respective officers, trustees, partners, members, agents, related entities, and volunteers arising from the work described in this Change Order and any other work affected by or related to the work described herein (collectively the "Change Order Work"). Thus as consideration for this Change Order, Contractor hereby releases all claims for any additional time or compensation extensions arising out of or related to the Change Order Work, including but not limited to, claims for additional time or compensation for any materials, labor, services, overhead, profit, and any time extensions or damages arising out of or related to any delays or impacts on the Contractor's schedule for performance of the Contract and Change Order Work ("Claims"). Contractor expressly waives any right to pursue any further Claims arising out of or related to the Change Order Work in any way including, but not limited to, cumulative impact claims associated with multiple changes. Any Contractor Claims back-up, change order proposals, change orders or other documentation that may be attached to this Change Order are agreed solely to described the changed work in question and, if applicable, the Contractor's pricing thereof, but does not vary, amend, alter in any way, the terms and conditions herein and the scope of the terms, conditions, agreements, payment amounts, releases, and waivers expressly set forth in this Change Order. Any estimated quantities of items of Unit Price Work are not guaranteed and are solely to determine an initial guaranteed maximum change order price. Engineer will determine the actual quantities and classifications of Unit Price Work that Contractor performs but in no event shall the final change in Contract Price or Times exceed the amount(s) set forth above.

Recommended By: _____ Date: _____
Warren County Engineer's Office
 Printed Name: _____

Accepted By: _____ Date: _____
Contractor
 Printed Name: _____

Accepted By: _____ Date: _____
Secretary-Treasurer – Warren County TID
 Printed Name: _____

SECTION VI

Prevailing Wage Rates



Mike DeWine
Governor

Sheryl Maxfield
Director

PREVAILING WAGE GUIDE

WARREN COUNTY

OHIO DEPARTMENT OF COMMERCE

Division of Industrial Compliance
Bureau of Wage and Hour Administration
6606 Tussing Road, PO Box 4009
Reynoldsburg, Ohio 43068-9009
Phone: 614-644-2239
Fax: 614-728-8639
www.com.ohio.gov
TTY/TDD: 1-800-750-0750

The Ohio Department of Commerce is an Equal Opportunity Employer and Service Provider

This packet of information is provided as a summary of the Prevailing Wage guidelines and responsibilities. The Ohio Revised Code, Chapter 4115 should be referred to for the exact wording of the law. Also included are references and forms which should be helpful in the compliance of the Prevailing Wage Law.

PACKET INFORMATION INDEX

- A. The Ohio Department of Commerce-Division of Industrial Compliance, Wage and Hour Administration Investigators and their assigned counties**
1. The Wage and Hour Investigators for the State of Ohio are listed with their contact information.
 - a. If you have questions or need assistance pertaining to Prevailing Wage, you can contact the Investigator in your area.
- B. Prevailing Wage Guide for Public Authorities**
1. Notice of change of the Prevailing Wage Threshold Level.
 - a. A notification will be sent to you when there is a change of the Prevailing Wage threshold level
 2. Outline of the Public Authority's responsibilities for Prevailing Wage.
 3. Public Authority's Compliance Checklist form.
 - a. A form for tracking the progress of a Prevailing Wage project
 4. Request form for Prevailing Wage Rates.
 - a. Prevailing Wage Rates can be obtained on the website www.com.ohio.gov
 - (1) Prevailing Wage Determination Schedule of wages must be attached to and made part of the specifications for the project, and must be printed on the bidding blanks where the work is done by contract.
 5. Bid Tabulation form
 - a. A form to be completed and returned to ODOC-DIC-Bureau of Wage and Hour Administration when the contract has been awarded.
 6. Prevailing Wage Bonds form
 - a. Information needed to be kept on file by the Prevailing Wage Coordinator when bonds from the Public Authority are used for a project.
- C. Prevailing Wage Guidelines for the Public Authority's Coordinator**
1. Guideline for the Prevailing Wage Coordinator
 - a. The Prevailing Wage complaint form and instructions can be obtained on the website www.com.ohio.gov
 2. Record of the Certified Payroll Reports Received form
 - a. Helpful form for recording the Certified Payroll Reports and the dates received from the contractors and subcontractors.
 3. Employee Interview form
 - a. Helpful form for the use by the Prevailing Wage Coordinator when making on-site visits.
 4. Employee vs. Independent Contractor
 - a. Helpful questions when determining if a person is an Employee or an Independent Contractor.
- D. Prevailing Wage Guide for Contractors**
(Incorporate this section in the Specifications or supply copies for the pre-construction meeting.)
1. Outline of responsibilities for the Prevailing Wage Contractor
 2. Notification form from the Contractor to the Employee
 - a. The contractor must submit to employees a completed and signed notification form.
 - b. Some Prevailing Wage Coordinators may require a copy of the completed Notification to the Employee form be submitted with the Certified Payroll Reports.
 3. Certified Payroll Report form
 - a. The contractor can use any form/format he chooses as long as **ALL** the information has been provided.
 4. Certified Payroll Report form instruction sheet
 5. Corrected Certified Payroll Report Example
 6. Affidavit of Compliance form
 - a. No Public Authority shall make final payment unless the **Final Affidavits** have been filed by the contractors and subcontractors.



Mike DeWine
Governor

Sheryl Maxfield
Director

INVESTIGATORS CONTACT INFORMATION

OHIO DEPARTMENT OF COMMERCE

Division of Industrial Compliance
Bureau of Wage and Hour Administration
6606 Tussing Road, PO Box 4009
Reynoldsburg, Ohio 43068-9009
Phone: 614-644-2239
Fax: 614-728-8639
www.com.ohio.gov
TTY/TDD: 1-800-750-0750

The Ohio Department of Commerce is an Equal Opportunity Employer and Service Provider

OHIO DEPARTMENT OF COMMERCE
Division of Industrial Compliance
Bureau of Wage and Hour Administration
Chief, Stephen Clegg

6606 Tussing Road, PO Box 4009
Reynoldsburg, Ohio 43068-9009
614-644-2239
fax: 614-728-8639
<http://www.com.ohio.gov>

INVESTIGATORS and THEIR HEADQUARTER COUNTY

#48 Dave Horvath PO Box 1512 Lima, Ohio 45802-1512 Voice: (419) 302-1200 Fax: (614) 728-8639 Dave.Horvath@com.state.oh.us	Allen *
#30 Mike McKee P.O. Box 1342 Cambridge, Ohio 43725-2247 Voice/Fax: (740) 432-1987 Michael.McKee@com.state.oh.us	Guernsey*
#56 Shawn Miles P.O. Box 2547 North Canton, Ohio 44720 Voice/Fax: (614) 496-9076 Shawn.Miles@com.state.oh.us	Stark *
#37 David Rice P.O. Box 41241 Dayton, Ohio 45441 Voice: (740) 502-0883 Fax: (614) 995-7768 Dave.Rice@com.state.oh.us	Montgomery *
#35 Sean Selbert P.O. Box 422 Painesville, Ohio 44077-3938 Voice: (614) 557-8662 Fax: (614) 232-9541 Sean.Selbert@com.state.oh.us	Lake *
#11 Kela D. Thompson 6606 Tussing Rd, PO Box 4009 Reynoldsburg, Ohio 43068-9009 Voice: (614) 728-5007 Fax: (614) 232-9537 Kela.Thompson@com.state.oh.us	Franklin *

* **Headquarter County**

Stephen Clegg, Chief 6606 Tussing Road, PO Box 4009 Reynoldsburg, Ohio 43068-9009 Voice: (614) 728-8686 Fax: (614) 728-8639 Stephen.Clegg@com.state.oh.us	#90 Jackie Clark, Supervisor 6606 Tussing Rd, PO Box 4009 Reynoldsburg, Ohio 43068-9009 Voice: (614) 728-5019 Fax: (614) 222-2357 Jackie.Clark@com.state.oh.us
--	--



Mike DeWine
Governor

Sheryl Maxfield
Director

PREVAILING WAGE GUIDE FOR PUBLIC AUTHORITIES

OHIO DEPARTMENT OF COMMERCE

Division of Industrial Compliance
Bureau of Wage and Hour Administration
6606 Tussing Road, PO Box 4009
Reynoldsburg, Ohio 43068-9009
Phone: 614-644-2239
Fax: 614-728-8639
www.com.ohio.gov
TTY/TDD: 1-800-750-0750

The Ohio Department of Commerce is an Equal Opportunity Employer and Service Provider

PREVAILING WAGE THRESHOLD LEVELS

IMPORTANT NOTICE

Before advertising for bids, contracting, or undertaking construction with its own forces, to construct a public improvement, the Public Authority shall have the Ohio Department of Commerce-Division of Industrial Compliance, Bureau of Wage and Hour Administration determine the prevailing rates of wages for workers employed on the public improvement. The wage determination must be included in the project specifications and printed on the bidding blanks where work is done by contract.

“New” construction threshold for <i>Building Construction</i>:	\$250,000
---	------------------

“Reconstruction, enlargement, alteration, repair, remodeling, renovation, or painting” threshold level for <i>Building Construction</i>:	\$75,000
---	-----------------

As of January 1, 2018:

“New” construction that involves <i>roads, streets, alleys, sewers, ditches and other works connected to road or bridge construction</i> threshold level has been adjusted to:	\$91,150
---	-----------------

“Reconstruction, enlargement, alteration, repair, remodeling, renovation, or painting” that involves <i>roads, streets, alleys, sewers, ditches and other works connected to road or bridge construction</i> threshold level has been adjusted to:	\$27,309
---	-----------------

- A) Thresholds are to be adjusted biennially by the Director of the Ohio Department of Commerce.
- B) Biennial adjustments to threshold levels are made according to the Building Cost for Skilled Labor Index published by McGraw-Hill’s Engineering News-Record, but may not increase or decrease more than 3% for any year.

If there are questions concerning this notification, please contact:

Ohio Department of Commerce
 Division of Industrial Compliance
 Bureau of Wage and Hour Administration
 6606 Tussing Road, PO Box 4009
 Reynoldsburg, Ohio 43068-9009
 Phone: 614-644-2239
 Fax: 614-728-8639
www.com.ohio.gov

Public Authority Responsibilities
ORC Chapter 4115: Wages and Hours on Public Works
(Prevailing Wage Coordinator)

1. Before advertising for bids, contracting, or undertaking construction with its own forces, to construct a public improvement, the public authority shall have the Ohio Department of Commerce, Division of Industrial Compliance, Bureau of Wage and Hour Administration determine the prevailing rates of wages for workers employed on the public improvement. The wage determination must be included in the project specifications and printed on the bidding blanks where work is done by contract.
 - a) "New" construction has a threshold level of **\$250,000**.
 - b) "Reconstruction, enlargement, alteration, repair, remodeling, renovation, or painting" has a threshold level of **\$75,000**.
 - c) "New" construction that involves roads, streets, alleys, sewers, ditches and other works connected to road or bridge construction has a threshold level of **\$84,314**.
 - d) "Reconstruction, enlargement, alteration, repair, remodeling, renovation, or painting" that involves roads, streets, alleys, sewers, ditches and other works connected to road or bridge construction has a threshold of **\$25,261**.
 - i.) Thresholds are to be adjusted biennially by the Director of Ohio Department of Commerce, Division of Industrial Compliance, Bureau of Wage and Hour Administration.
 - ii.) Biennial adjustments to threshold levels are made according to the Price Deflator for Construction Index, United States Department of Commerce, Bureau of the Census, but may not increase or decrease more than 3% for any year.
2. Every contract for public work shall contain a provision that each worker employed by the contractor or subcontractor, or other person about or upon the public work, must be paid the prevailing rate of wages.
3. If contracts are not awarded or construction undertaken within ninety days (90) from the date of the determination of the prevailing wage there shall be a re-determination of the wage rates before the contract is awarded.
4. Within **seven (7) working days** after the receipt of notification of a change in the prevailing wage rates, the public authority shall notify all affected contractors and subcontractors. If it is determined that a contractor or subcontractor has violated sections 4115.03 to 4115.16 of the Ohio Revised Code because they were not notified as required, **the public authority is liable** for any back wages, fines, damages, court costs and attorney's fees for the period of time covering the receipt of wage changes, until they give the required notice.
5. No public authority shall award a contract for a public improvement to any contractor or subcontractor whose name appears on the list of debarred contractors. This list is filed with the Secretary of State by the Ohio Department of Commerce-Division of Industrial Compliance & Labor-Bureau of Wage and Hour Administration **The filing of the notice of conviction with the secretary of state constitutes notice to all public authorities.** These contractors are prohibited from working on public improvements for periods ranging from one to three years. The list of debarred contractors can be located on the website www.com.ohio.gov/laws
6. A public authority must designate and appoint **one of its own employees** to serve as the Prevailing Wage Coordinator during the life of the contract for constructing the public improvement. A Prevailing Wage Coordinator must be appointed no later than ten days before the first payment of wages by contractors to employees working on the public improvement.

PUBLIC AUTHORITY'S COMPLIANCE CHECKLIST FOR PREVAILING WAGE

Project:		Number:
Department:		Phone#:
PW Coordinator:		Phone#:
Architect/Engineer:		Phone#:
Contractor:		Phone#:
Contact Person:		Title:
General Contractor:		Prime Contractor:
		Construction Mgr:
Date Completed		Compliance Item Description
	1.	Request Prevailing Wage Determination Schedule from ODOC-DIC-Wage & Hour
	2.	Received Prevailing Wage Determination Schedule
	3.	Incorporate Determination Schedule in Specs./Bidding Blanks
	4.	Incorporate notice of Prevailing Wage requirements in Invitation for Bids/Notice to Bidders
	5.	Incorporate Prevailing Wage requirements in Contract
	6.	Submit complete Invitation for Bid to ODOC-DIC-Wage & Hour
	7.	Invitation for Bids
	8.	Bid Opening
	9.	Check Listing of Violators
	10.	Award of Contract. (see note)
	11.	Submit Bid Tabulation/Award to ODOC-DIC-WAGE & HOUR
	12.	Notice to Successful Bidder
	13.	Work Commenced...(see note)
	14.	Appoint Prevailing Wage Coordinator
	15.	Received list of Subcontractors' names, addresses, phone #'s & email's
	16.	Received Payroll Date Schedule
	17.	Received Registered Apprenticeship Agreement Certifications
	18.	Received Deduction Agreements
	19.	Received Payroll Reports with Certification...(see attachment)
	20.	Visited project site
	21.	Received Changes to Determination Schedule
	22.	Notice to Contractors of Determination Schedule change
	23.	Request Final Compliance Affidavit from contractors & subcontractors
	24.	Received Final Affidavits from all contractors & subcontractors
	25.	Certify Final Payment

Note: If contract is not awarded or construction undertaken within 90 days from the date of establishment of the Prevailing Wage Rates, a re-determination of the Prevailing Wage Rates is required.

REQUEST FOR STATE OF OHIO PREVAILING WAGE RATES

Date		(Mark (X) One)		<input type="checkbox"/> ~ Residential	<input type="checkbox"/> ~ Construction		
Project Information (only one project and one county per request form please)							
County of Project		Project Name		This form MUST be filled out COMPETELY & CORRECTLY for us to process your request. Forms not completed correctly will be RETURNED TO THE SENDER .			
Site Address		City					
Owner/Public Authority						Prevailing Wage Rates can be obtained on the website www.com.ohio.gov	
Address		Telephone Number		<div style="border: 2px solid black; padding: 5px; margin-bottom: 5px;">ODOC-DIC-WAGE & HOUR DATE STAMP</div>			
City		Zip Code					
PW Coordinator		Telephone Number					
Issuing Authority of Bonds		Type of Financing					
Estimated Total Overall Project Cost						PLEASE MAIL THIS REQUEST TO: Ohio Department of Commerce Division of Industrial Compliance Bureau of Wage & Hour Administration 6606 Tussing Road, PO Box 4009 Reynoldsburg, Ohio 43068-9009 PHONE: (614) 644-2239 FAX: (614) 728-8639	
<input type="checkbox"/> New Construction		<input type="checkbox"/> "Old" Construction *					
A copy of this form will be returned to you with your wage rates. You must send that copy to us with your bid tabulations once the contract has been awarded.							
Expected Date of Contract Award							
Projected Completion Date				<div style="border: 2px solid black; padding: 5px; margin-bottom: 5px;">ODOC-DIC-W&H DATE STAMP (bid tab)</div>			
Send Wage Rates to: (contractors are charged \$5.00 per county)							
<input type="checkbox"/> Mail		<input type="checkbox"/> Pick Up					
<input type="checkbox"/> Federal Express Account Number							
Name		Company or Public Authority		<div style="border: 2px solid black; padding: 5px; margin-bottom: 5px;">ODOC-DIC-W&H DATE STAMP (bid tab)</div>			
Address							
City		Zip	Telephone Number				
* "Old" construction is reconstruction, enlargement, alteration, repair, remodeling, renovation, or painting.							

INDUSTRIAL DEVELOPMENT BONDS

Bond Projects require the Public Authority to keep the following information on file			
1. Type of Bonds issued:	Amount:		
2. The total cost of the Project:			
3. The other type of financing involved in the project:			
4. Portion of the project being constructed with each type of financing:			
5. Are Prevailing Wage Rates being applied to all construction on the project: <input type="checkbox"/> Yes <input type="checkbox"/> No			
6. The name of the political subdivision who issued the bonds:			
7. When were the bonds issued:			
8. For what purpose were the bonds issued:			
9. Who handles the funds once the bonds are sold:			
10. Who is the lending institution that purchased the bonds:			
11. How are the funds to be paid out:			
12. When are the funds to be paid out:			
13. Who is the Bond Council:			
14. Who has been appointed as the Prevailing Coordinator:			
PWC Address:			
City:	OHIO	Zip:	Telephone #:
15. Obtain a copy of the inducement and other official documents for the issuance of the bonds.			



Mike DeWine
Governor

Sheryl Maxfield
Director

PREVAILING WAGE GUIDELINES
FOR THE
PUBLIC AUTHORITY'S
PW COORDINATOR

OHIO DEPARTMENT OF COMMERCE

Division of Industrial Compliance and Labor

Bureau of Wage and Hour Administration

6606 Tussing Road, PO Box 4009

Reynoldsburg, Ohio 43068-9009

Phone: 614-644-2239

Fax: 614-728-8639

www.com.ohio.gov

TTY/TDD: 1-800-750-0750

The Ohio Department of Commerce is an Equal Opportunity Employer and Service Provider

Prevailing Wage Coordinator Guidelines

For more detailed information please refer to Chapter 4115 of the Ohio Revised Code

- A. Attend any pre-bid and/or pre-construction meetings.
 - 1. To explain the prevailing wage rate requirements.
 - 2. To explain the contractor's responsibilities.
- B. Set up and maintain files containing all contractors' and subcontractors' payroll reports, affidavits, and related documents. These files must be available for public inspection.
- C. Obtain from each contractor a list of their subcontractors' names, addresses, telephone numbers, and email addresses.
- D. Require each contractor and subcontractor to provide their project dates. This will be used to make a time schedule for receiving their certified payrolls.
- E. Obtain from each contractor, the name and address of their Bonding/Surety Company.
- F. Obtain from out-of-state corporations, the name and address of their Statutory Agent. (This agent must be located in the State of Ohio and registered with the Ohio Secretary of State.)
 - 1. Records made in connection with the public improvement must not be removed from the State of Ohio for the period of one year following the completion of the project.
- G. Supply contractors with any changes in the Prevailing Wage Rates.
- H. Within two weeks after the first pay, obtain a certified payroll report from each contractor. A certified report is one that is sworn to and signed by the contractor.
 - 1. If the job will exceed four months, all reports after the initial report can be filed once per month. (The initial report must be filed within two weeks.)
 - 2. If the job will last less than four months, all reports are to be filed weekly after the initial report.
- I. Establish and follow procedures to monitor compliance by contractors and subcontractors.
 - 1. Visit project to verify posting requirements and job classifications.
 - 2. Review certified payroll reports to ensure they are submitted in a timely fashion and complete with the following information for each employee:
 - a) Name, current address, and their social security number or last 4 when permitted
 - b) Classification (must be specific for laborers and operators, including level)
 - c) Hours worked on the project
 - d) Hourly rate
 - e) Fringe benefits, if applicable
 - f) Total hours worked for the week (all jobs)
 - g) Gross wages, all deductions, net pay
 - 3. Compare rates and fringes reported to rates in prevailing wage schedule.
- J. Upon completion of the project and prior to the final payment, require an affidavit of compliance from each contractor and subcontractor. **No public authority shall make final payment to any contractor or subcontractor unless the final affidavits have been filed by the respective contractor and subcontractor. (O.R.C. section 4115.07)**
- K. Report any non-compliance to Ohio Department of Commerce, Division of Industrial Compliance, Bureau of Wage & Hour Administration. The PW complaint form and instructions can be obtained on the website www.com.ohio.gov.

RECORD OF THE CERTIFIED PAYROLL REPORTS RECEIVED

Project:		Number:
Contractor:		Phone #: Email:
General Contractor:	Prime Contractor:	Subcontractor:
Date work commenced:	Completed:	Final Affidavit:

Payroll	Payroll Date	Date Received	Payroll	Payroll Date	Date Received
1			33		
2			34		
3			35		
4			36		
5			37		
6			38		
7			39		
8			40		
9			41		
10			42		
11			43		
12			44		
13			45		
14			46		
15			47		
16			48		
17			49		
18			50		
19			51		
20			52		
21			53		
22			54		
23			55		
24			56		
25			57		
26			58		
27			59		
28			60		
29			61		
30			62		
31			63		
32			64		

PREVAILING WAGE INVESTIGATION\EMPLOYEE INTERVIEW

Failure to complete this interview form may reduce our ability to recover back wages which may be owed to you.

Project:		Case #:	
Address:		City:	County:
Employee Name:		Last 4 digits of the SS#:	
Address:	City:	State:	Zip:
Telephone #: (Home)	(Work)	Email:	Best time to be reached:
Another source by which we can contact you.(Someone not living at your address):			
Name:		Relationship:	Telephone #:
Contractor's Name:		Telephone #:	
Address:		City:	State: Zip:
Date hired:	Date started on this project :	Approximate hours - Straight time:	Overtime:
Method of recording hours: <input type="checkbox"/> Time Card <input type="checkbox"/> Called into office		Recorded by: <input type="checkbox"/> Employee <input type="checkbox"/> Foreman	
Did you keep a personal record of your hours worked on this project? <input type="checkbox"/> Yes <input type="checkbox"/> No		Do you have check stubs? <input type="checkbox"/> Yes <input type="checkbox"/> No	
Did anyone else keep a personal record ? <input type="checkbox"/> Yes <input type="checkbox"/> No		If yes, who:	
List your job classification(s):		<input type="checkbox"/> Journeyman <input type="checkbox"/> Helper <input type="checkbox"/> Apprentice - Level	
List your specific job duties:		List tools\equipment used:	
Hourly rate of pay for this project:		Your regular rate of pay:	
Fringe benefits paid by contractor: <input type="checkbox"/> None <input type="checkbox"/> Health Insurance <input type="checkbox"/> Life Insurance <input type="checkbox"/> Pension <input type="checkbox"/> Bonus ~ Vacation - Amount _____ <input type="checkbox"/> Holidays - Amount _____ <input type="checkbox"/> Apprenticeship training <input type="checkbox"/> Profit Sharing ~ Other (list):			
Did you work overtime? <input type="checkbox"/> Yes <input type="checkbox"/> No		Were hours over 40 per week paid at time and one half? <input type="checkbox"/> Yes <input type="checkbox"/> No	
When is your pay day?		Method of payment: <input type="checkbox"/> Check <input type="checkbox"/> Cash <input type="checkbox"/> Direct Deposit	
List names of co-workers on this project:			
Comments:		Please provide a detailed list of the dates, times and hours worked within each classification that may apply to the work performed on a separate sheet.	
SIGNATURE AND NOTARY			
Affiant is further informed that Section 2921.13 of the Ohio Revised Code provides a penalty of a misdemeanor of the first degree and that prosecution will be pursued of those persons who "knowingly swear or affirm the truth of a false statement when ...the statement is sworn or affirmed before a notary public..." Sworn to before me and subscribed by the said: _____ in my presence this _____ day of _____, 20_____. _____ Notary Public		I hereby certify that this is a true statement to the best of my knowledge and belief. Signature _____ Date _____ Return to: Ohio Department of Commerce Division of Industrial Compliance & Labor Bureau of Wage and Hour Administration 6606 Tussing Road P.O. Box 4009 Reynoldsburg, Ohio 43068-9009 (614) 644-2239 www.com.ohio.gov	
Signature of PW Coordinator:		Date:	

EMPLOYEE VS. INDEPENDENT CONTRACTOR

EMPLOYEE	↔	<input checked="" type="checkbox"/> YES	Does the employer have the right to control and direct worker?	<input type="checkbox"/> NO	↔	INDEPENDENT CONTRACTOR
EMPLOYEE	↔	<input checked="" type="checkbox"/> YES	Does the worker receive instructions about how and where the work is to be done instead of the employer merely specifying the desired result?	<input type="checkbox"/> NO	↔	INDEPENDENT CONTRACTOR
EMPLOYEE	↔	<input checked="" type="checkbox"/> YES	Is payment based on time spent rather than a set price for the work to be performed?	<input type="checkbox"/> NO	↔	INDEPENDENT CONTRACTOR
EMPLOYEE	↔	<input checked="" type="checkbox"/> YES	Does the worker devote virtually all his working time to the employer rather than offering services to the general public?	<input type="checkbox"/> NO	↔	INDEPENDENT CONTRACTOR
EMPLOYEE	↔	<input checked="" type="checkbox"/> YES	Does the worker performing services make their services available to the general public and/or other businesses?	<input type="checkbox"/> NO	↔	INDEPENDENT CONTRACTOR
EMPLOYEE	↔	<input checked="" type="checkbox"/> YES	Is there a continuing relationship between employer and worker?	<input type="checkbox"/> NO	↔	INDEPENDENT CONTRACTOR
EMPLOYEE	↔	<input checked="" type="checkbox"/> YES	Can the worker be discharged at will?	<input type="checkbox"/> NO	↔	INDEPENDENT CONTRACTOR
EMPLOYEE	↔	<input checked="" type="checkbox"/> YES	Did the employer train the worker for the job?	<input type="checkbox"/> NO	↔	INDEPENDENT CONTRACTOR
EMPLOYEE	↔	<input checked="" type="checkbox"/> YES	Does the employer have employees performing the same work as the independent contractor?	<input type="checkbox"/> NO	↔	INDEPENDENT CONTRACTOR

EMPLOYEE VS. INDEPENDENT CONTRACTOR-continued

EMPLOYEE ↔ YES NO ↔ INDEPENDENT CONTRACTOR
Does the worker perform services personally rather than delegating them to others?

EMPLOYEE ↔ YES NO ↔ INDEPENDENT CONTRACTOR
Does the employer set a specific time when the individual services are to be performed?

EMPLOYEE ↔ YES NO ↔ INDEPENDENT CONTRACTOR
Does the employer furnish the tools and materials used by the worker performing services?

EMPLOYEE ↔ YES NO ↔ INDEPENDENT CONTRACTOR
Is the employer assuming all the financial risk, rather than the worker making a significant financial investment in the job and having the opportunity to realize a profit or loss from the work?

EMPLOYEE ↔ YES NO ↔ INDEPENDENT CONTRACTOR
Does the individual performing the services publicly advertise these services in for example, the newspaper or yellow pages ?

EMPLOYEE ↔ YES NO ↔ INDEPENDENT CONTRACTOR
Does the individual performing the services have a business license?

EMPLOYEE ↔ YES NO ↔ INDEPENDENT CONTRACTOR
Does the individual performing the services operate d.b.a. or under a tradename?



Mike DeWine
Governor

Sheryl Maxfield
Director

PREVAILING WAGE GUIDE FOR CONTRACTORS

OHIO DEPARTMENT OF COMMERCE

Division of Industrial Compliance
Bureau of Wage and Hour Administration
6606 Tussing Road, PO Box 4009
Reynoldsburg, Ohio 43068-9009
Phone: 614-644-2239
Fax: 614-728-8639
www.com.ohio.gov
TTY/TDD: 1-800-750-0750

The Ohio Department of Commerce is an Equal Opportunity Employer and Service Provider

OHIO DEPARTMENT OF COMMERCE
 Division of Industrial Compliance
 Bureau of Wage and Hour Administration
 Chief, Stephen Clegg

6606 Tussing Road, PO Box 4009
 Reynoldsburg, Ohio 43068-9009
 614-644-2239
 fax: 614-728-8639
<http://www.com.ohio.gov>

INVESTIGATORS and THEIR HEADQUARTER COUNTY

<p>#48 Dave Horvath PO Box 1512 Lima, Ohio 45802-1512 Voice: (419) 302-1200 Fax: (614) 728-8639 Dave.Horvath@com.state.oh.us</p>	<p>Allen *</p>
<p>#30 Mike McKee P.O. Box 1342 Cambridge, Ohio 43725-2247 Voice/Fax: (740) 432-1987 Michael.McKee@com.state.oh.us</p>	<p>Guernsey*</p>
<p>#56 Shawn Miles P.O. Box 2547 North Canton, Ohio 44720 Voice/Fax: (614) 496-9076 Shawn.Miles@com.state.oh.us</p>	<p>Stark *</p>
<p>#37 David Rice P.O. Box 41241 Dayton, Ohio 45441 Voice/Fax: (740) 502-0883 Dave.Rice@com.state.oh.us</p>	<p>Montgomery *</p>
<p>#35 Sean Seibert P.O. Box 422 Painesville, Ohio 44077-3938 Voice: (614) 557-8662 Fax: (614) 232-9541 Sean.Seibert@com.state.oh.us</p>	<p>Lake *</p>
<p>#11 Kela D. Thompson 6606 Tussing Rd, PO Box 4009 Reynoldsburg, Ohio 43068-9009 Voice: (614) 728-5007 Fax: (614) 232-9537 kela.thompson@com.state.oh.us</p>	<p>Franklin *</p>

* **Headquarter County**

<p>Stephen Clegg, Chief 6606 Tussing Road, PO Box 4009 Reynoldsburg, Ohio 43068-9009 Voice: (614) 728-8686 Fax: (614) 728-8639 Stephen.Clegg@com.state.oh.us</p>	<p>#90 Jackie Clark, Supervisor 6606 Tussing Rd, PO Box 4009 Reynoldsburg, Ohio 43068-9009 Voice: (614) 728-5019 Fax: (614) 222-2357 Jackie.Clark@com.state.oh.us</p>
---	---



PREVAILING WAGE CONTRACTOR RESPONSIBILITIES

This is a summary of prevailing wage contractors' responsibilities. For more detailed information please refer to Chapter 4115 of the Ohio Revised Code

General Information

Ohio's prevailing wage laws apply to all public improvements financed in whole or in part by public funds when the total overall project cost is fairly estimated to be more than \$250,000 for new construction or \$75,000 for reconstruction, enlargement, alteration, repair, remodeling, renovation, or painting.

Ohio's prevailing wage laws apply to all public improvements financed in whole or in part by public funds when the total overall project cost is fairly estimated to be more than \$91,150 for new construction that involves roads, streets, alleys, sewers, ditches and other works connected to road or bridge construction or \$27,309 for reconstruction, enlargement, alteration, repair, remodeling, renovation, or painting of a public improvement that involves roads, streets, alleys, sewers, ditches and other works connected to road or bridge construction.

- a) Thresholds are to be adjusted biennially by the Administrator of Ohio Department of Commerce, Division of Industrial Compliance and Labor, Bureau of Wage and Hour Administration
- b) Biennial adjustments to threshold levels are made according to the Price Deflator for Construction Index, United States Department of Commerce, Bureau of the Census*, but may not increase or decrease more than 3% for any year

Penalties for violation

Violators are to be assessed the wages owed, plus a penalty of 100% of the wages owed.

Intentional Violations

If an intentional violation is determined to have occurred, the contractor is prohibited from contracting directly or indirectly with any public authority for the construction of a public improvement. Intentional violation means "a willful, knowing, or deliberate disregard for any provision" of the prevailing wage law and includes but is not limited to the following actions:

- Intentional failure to submit payroll reports as required, or knowingly submitting false or erroneous reports.
- Intentional misclassification of employees for the purpose of reducing wages.
- Intentional misclassification of employees as independent contractors or as apprentices.
- Intentional failure to pay the prevailing wage.
- Intentional failure to comply with the allowable ratio of apprentices to skilled workers as required by the regulations established by Ohio Department of Commerce, Division of Industrial Compliance and Labor, Bureau of Wage and Hour Administration.
- Intentionally employing an officer, of a contractor or subcontractor, that is known to be prohibited from contracting, directly or indirectly, with a public authority.



Responsibilities

- A. Pay the prevailing rate of wages as shown in the wage rate schedules issued by the Ohio Department of Commerce, Division of Industrial Compliance and Labor, Bureau of Wage and Hour Administration, for the classification of work being performed.
 1. Wage rate schedules include all modifications, corrections, escalations, or reductions to wage rates issued for the project.
 2. Overtime must be paid at time and one-half the employee's base hourly rate. Fringe benefits are paid at straight time rate for all hours including overtime.
 3. Prevailing wages must be paid in full without any deduction for food, lodging, transportation, use of tools, etc.; unless, the employee has voluntarily consented to these deductions in writing. The public authority and the Director of Ohio Department of Commerce, Division of Industrial Compliance and Labor, Bureau of Wage and Hour Administration - must approve these deductions as fair and reasonable. Consent and approval must be obtained before starting the project.

- B. Use of Apprentices and Helpers cannot exceed the ratios permitted in the wage rate schedules.
 1. Apprentices must be registered with the U.S. Department of Labor Bureau of Apprenticeship and Training.
 2. Contractors must provide the Prevailing Wage Coordinator a copy of the Apprenticeship Agreement for each apprentice on the project.

- C. Keep full and accurate payroll records available for inspection by any authorized representative of the Ohio Department of Commerce, Division of Industrial Compliance, and Labor, Bureau of Wage and Hour Administration or the contracting public authority, including the Prevailing Wage Coordinator. Records should include but are not limited to:
 1. Time cards, time sheets, daily work records, etc.
 2. Payroll ledger\journals and canceled checks\check register.
 3. Fringe benefit records must include program, address, account number, & canceled checks.
 4. Records made in connection with the public improvement must not be removed from the State for one year following the completion of the project.
 5. Out-of-State Corporations must submit to the Ohio Secretary of State the full name and address of their Statutory Agent in Ohio.

- D. Prevailing Wage Rate Schedule must be posted on the job site where it is accessible to all employees.

- E. Prior to submitting the initial payroll report, supply the Prevailing Wage Coordinator with your project dates to schedule reporting of your payrolls.

- F. Supply the Prevailing Wage Coordinator a list of all subcontractors including the name, address, and telephone number for each.
 1. **Contractors are responsible for their subcontractors' compliance with requirements of Chapter 4115 of the Ohio Revised Code.**



**Department
of Commerce**

Division of Industrial Compliance

- G. Before employees start work on the project, supply them with written notification of their job classification, prevailing wage rate, fringe benefit amounts, and the name of the Prevailing Wage Coordinator for the project. A copy of the completed signed notification should be submitted to Prevailing Wage Coordinator.
- H. Supply all subcontractors with the Prevailing Wage Rates and changes.
- I. Submit certified payrolls within two (2) weeks after the initial pay period. Payrolls must include the following information:
 - 1. Employees' names, addresses, and social security numbers.
 - a. Corporate officers/owners/partners and any salaried personnel who do physical work on the project are considered employees. All rate and reporting requirements are applicable to these individuals.
 - 2. Employees' work classification.
 - a. Be specific about the laborers and/or operators (Group)
 - b. For all apprentices, show level/year and percent of journeyman's rate
 - 3. Hours worked on the project for each employee.
 - a. The number of hours worked in each day and the total number of hours worked each week.
 - 4. Hourly rate for each employee.
 - a. The minimum rate paid must be the wage rate for the appropriate classification. The Department's Wage Rate Schedule sets this rate.
 - b. All overtime worked is to be paid at time and one-half for all hours worked more than forty (40) per week.
 - 5. Where fringes are paid into a bona fide plan instead of cash, list each benefit and amount per hour paid to program for each employee.
 - a. When the amount contributed to the fringe benefit plan and the total number of hours worked by the employee on all projects for the year are documented, the hourly amount is calculated by dividing the total contribution of the employer by the total number of hours worked by the employee.
 - b. When the amount contributed to the fringe benefit is documented but not the total hours worked, the hourly amount is calculated by **dividing the total yearly contribution by 2080.**
 - 6. Gross amount earned on all projects during the pay period.
 - 7. Total deductions from employee's wages.
 - 8. Net amount paid.
- J. The reports shall be certified by the contractor, subcontractor, or duly appointed agent stating that the payroll is correct and complete; and that the wage rates shown are not less than those required by the O.R.C. 4115.
- K. Provide a Final Affidavit to the Prevailing Wage Coordinator upon the completion of the project.

PREVAILING WAGE NOTIFICATION to EMPLOYEE

4115.05...the contractor or subcontractor shall furnish each employee NOT covered by a collective bargaining agreement written notification of the job classification to which the employee is assigned, the prevailing wage determined to be applicable to that classification, separated into the hourly rate of pay and the fringe payments, and the identity of the prevailing wage coordinator appointed by the public authority. The contractor or subcontractor shall furnish the same notification to each affected employee every time the job classification of the employee is changed.

Project Name:	Job Number:
Contractor:	
Project Location:	

Prevailing Wage Coordinator	Employee
Public Authority:	Name:
Name of PWC:	Street:
Street:	City:
City:	State/Zip:
State/Zip:	Phone:
	Email:
Phone:	Last 4 Digits of SS #:

You will be performing work on this project that falls under these classifications. You will be paid the appropriate rate for the type of work you are performing.

Classification:	Prevailing Wage Rate Total Package:	Minus your fringe benefits *:	Your hourly base rate and overtime:
			/
			/
			/
			/
			/
			/
			/

Hourly fringe benefits paid on your behalf by this company (Yearly amount the company pays divided by 2080):

Fringe	Amount	Fringe	Amount
Health Insurance		Vacation	
Life Insurance		Holiday	
Pension		Sick Pay	
Other (Specify)		Training	
Other (Specify)		Total Hourly Fringes *	

Contractor's Signature:	Date:
Employee's Signature:	Date:

INSTRUCTIONS FOR PREPARING CERTIFIED PAYROLL REPORTS

General

Contractors and subcontractors are required by law to submit certified payroll reports for work on projects covered by Ohio's Prevailing Wage Law. This form meets the reporting requirements established by Ohio Revised Code Chapter 4115. The use of this form is not mandatory; employers may submit their own forms provided that all of the required information is included. This form may be reproduced, or additional copies obtained from:

Ohio Department of Commerce
Division of Industrial Compliance and Labor
Bureau of Wage & Hour Administration
6606 Tussing Rd, P. O. Box 4009
Reynoldsburg, OH 43068-9009
Phone: (614) 644-2239
www.com.ohio.gov

Certified Payroll Heading

Employer name and address: Company's full name and address... Indicate if the company is a subcontractor.

Subcontractor: Check and list the name of the General Contractor or Prime.

Project: Name and location of the project, including county.

Contracting Public Authority: Name and address of the contracting public authority... (Owner of the project).

Week Ending: Month, day, and year for the last day of the reporting period.

Payroll #: Indicate first, second, third, etc. payroll filed by the company for the project.

Page Indicator: number of pages included in the report.

Project Number: Determined by the public authority... if there is no number leave it blank.

Payroll Information by Column

- Employee Name, Address and Social Security number:** This information must be provided for all employees that perform physical labor on the project. Corporate officers, partners, and salaried employees are considered employees and must be paid the prevailing rate. Individual sole proprietors do not have to pay themselves prevailing rate but must report their hours on the project.
- Work Class:** List classification of work actually performed by employee. If unsure of work classification, consult the Ohio department of Commerce, Wage and Hour Bureau. Employees working more than one classification should have separate line entries for each classification. Indicate what year/level for Apprentices. Be specific when using laborer and operator classifications; for example, Backhoe Operator or Asphalt Laborer.
- Hours Worked, Day & Date:** In the first row of column 3 enter days of pay period example; M T W T H F S S. The second row is for the date that corresponds with each day for the pay period. In the employee information section enter the number of hours worked on the prevailing wage project and which day the hours were worked. Separate rows are labeled for (ST) straight time hours and (OT) overtime hours. All hours worked after 40, must be paid at the appropriate overtime rate.
- Project Total Hours:** Total the hours entered for pay period.
- Base Rate:** Enter actual rate per hour paid to the employee. The overtime hourly rate is time and one-half the base rate listed in the prevailing wage schedule plus fringe benefits at straight time rate. The prevailing wage schedule lists the base rate plus fringe benefit amounts. These amounts added together equal the total prevailing wage rate. Employers must pay this total amount in one of three ways.
 - Total rate may be paid in entirety in the base rate to the employee; in which case, the cash designation will be checked for fringe benefits.
 - Total rate may be paid as listed in prevailing wage rate schedule with total fringe amounts paid approved plans.
 - Total rate may be paid with a combination of base rate and fringe payments to approved plans in amounts other than those listed in schedule.
- Project Gross:** Enter total gross wages earned on the project for straight time and overtime. Project hours X base rate should equal project gross.
- Fringes:** If fringe benefits are paid in the hourly base rate, indicate this by marking the **Cash** space. If fringe benefits are paid to approved plans as listed in the prevailing wage rate schedule, mark the space **Approved Plans**. If fringe benefits are paid partially in the base rate and partially to approved plans, mark the space **Cash & Approved plans**. List the hourly amount paid to approved plans for each fringe. If payments are not made on a per hour basis, **calculate the hourly fringe credit by dividing the yearly employer contribution by** the lesser of: hours actually worked in the year (these must be documented) or 2080. Fringe benefits include: **Employer's share** of health insurance, life insurance, retirement plan, bonus/profit sharing, sick pay, holiday pay, personal leave, vacation, and education/training programs. If unsure of a possible fringe benefit, contact the Ohio Department of Commerce - Division of Industrial Compliance and Labor - Bureau of Wage & Hour Administration.
- Total Hours All Jobs:** Total all hours worked during the pay period including non-prevailing wage jobs.
- Total Gross All Jobs:** Gross amount earned in the pay period for all hours worked.
- Self explanatory.
- Self explanatory

Certified Payroll Report

Report for: Check if Subcontractor¹⁾ Contract No: _____ Payroll No: _____
 Company:¹⁾ _____ If Sub, GC/Prime Contractor Name: _____ Project Name & Location: _____
 Address: _____ Public Authority (Owner): _____ Week Ending: _____
 City, State, Zip _____ Sheet:²⁾ _____ of _____

1. Employee Name, Address, & SS# (Last 4 digits if permitted)	2. Work Class ³⁾	3. Prevailing Wage Project		4. Total Hours	5. Base Rate	6. Project Gross	7. Fringes:				8. Total Hrs for all Jobs			9. Total Gross on All Jobs			10. Total Deductions		11. Net Pay on All Jobs	
		Hours Worked - Day & Date					Fringe Rate: Your Company Pays Per Hour				H&W	Pens	Vac	Hol	Other	Total	Total	Total		Total
							Cash & Approved Plans	Cash	Approved Plans											
	OT																			
	ST																			
	OT																			
	ST																			
	OT																			
	ST																			
	OT																			
	ST																			
	OT																			
	ST																			

1) By signing below, I certify that: (1) I pay, or supervise the payment of the employees shown above; (2) during the pay period reported on this form, all hours worked on this project have been paid at the appropriate prevailing wage rate for the class of work done; (3) the fringe benefits have been paid as indicated above; (4) no rebates or deductions have been or will be made, directly or indirectly from the total wages earned, other than permissible deductions as defined in ORC Chapter 4115; and (5) apprentices are registered with the U.S. Dept. of Labor, Bureau of Apprenticeship and Training. I understand that the willful falsification of any of the above statements may subject the Contractor or Subcontractor to civil or criminal prosecution.

Type or Print Name and Title _____ Signature _____ Date _____

11/14 jc ²⁾ Attach additional sheets as necessary. ³⁾ Type in continuous line, text will wrap.

DO NOT REDO FORM AND CHANGE RATES IF AN ERROR HAS BEEN MADE! SUBMIT A CORRECTED REPORT

Fill out all other areas of the form as usual

*** CORRECTED ***

Certified Payroll Report

Difference in base rate & corrected base rate if applicable

Total Hours being corrected for this indiv.

1. Employee Name, Address & SS# (Last 4 digits if permitted)

Check if Subcontractor¹⁾ Contract No: _____
 If Sub, GC/Prime Contractor Name: _____
 Public Authority (Owner): _____
 City, State, Zip: _____
 Phone No: _____
 Payroll No: _____
 Week Ending: _____
 Sheet²⁾ _____ of _____

1. Employee Name, Address & SS# (Last 4 digits if permitted)	2. Work Class ³⁾	3. Prevailing Wage Project Hours Worked - Day & Date	4. Total Hours	5. Base Rate	6. Project Gross	7. Fringes	Fringe Rate Your Company Pays Per Hour					8. Total Hrs for all Jobs	9. Total Gross on All Jobs	10. Total Deductions	11. Net Pay on All Jobs										
							H&W	Pens	Vac	Hol	Other					Total									
Name Address Last 4 SSN Class OT ST OT ST OT ST OT ST	Class																								
																Put the period that is being corrected, i.e.: Oct 26 to Nov 02, not individual weekly dates									
																Difference in fringes & corrected fringes if applicable.									
																Difference in base rate & corrected base rate if applicable									
																Total Hours being corrected for this indiv.									
																The net paid will be the total of difference paid and the total hours being corrected. Provide check # in the margin.									

1) By signing below, I certify that: (1) I pay, or supervise the payment of the employees shown above; (2) during the pay period reported on this form, all hours worked on this project have been paid at the appropriate prevailing wage rate for the class of work done; (3) the fringe benefits have been paid as indicated above; (4) no rebates or deductions have been or will be made, directly or indirectly from the total wages earned, other than permissible deductions as defined in ORC Chapter 4115; and (5) apprentices are registered with the U.S. Dept. of Labor, Bureau of Apprenticeship and Training. I understand that the willful falsification of any of the above statements may subject the Contractor or Subcontractor to civil or criminal prosecution.

Type or Print Name and Title _____ Signature _____ Sign _____ Date _____

11/14 jc ²⁾Type in continuous line, text will wrap. ³⁾Attach additional sheets as necessary.

Send cover letter stating what happened along with a signed letter from the employee acknowledging that they were underpaid, received payment, check or transaction number. Contractor provided cancelled endorsed bank check.

IMPORTANT NOTICE - This process may be different if the Public Authority is using LCPTracker or some other online system to collect Certified Payroll Report from the contractors.



Department of Commerce

Division of Industrial Compliance

Affidavit of Compliance

Prevailing Wages

I, _____
(Name of person signing affidavit) (Title)

do hereby certify that the wages paid to all employees of

(Company Name)

for all hours worked on the

(Project name and location)

project, during the period from _____ to _____ are in
(Project Dates)

compliance with prevailing wage requirements of Chapter 4115 of the Ohio Revised Code. I further certify that no rebates or deductions have been or will be made, directly or indirectly, from any wages paid in connection with this project, other than those provided by law.

(Signature of Officer or Agent)

Sworn to and subscribed in my presence this _____ day of _____, 20_____.

(Notary Public)

The above affidavit must be executed and sworn to by the officer or agent of the contractor or subcontractor who supervises the payment of employees. This affidavit must be submitted to the owner (public authority) before the surety is released or final payment due under the terms of the contract is made.

THIS PAGE WAS LEFT BLANK INTENTIONALLY

Prevailing Wage Rate Skilled Crafts

Name of Union: Asbestos Local 50 Zone 1

Change # : LCN01-2020fbLoc50

Craft : Asbestos Worker Effective Date : 03/25/2020 Last Posted : 03/25/2020

	BHR		Fringe Benefit Payments						Irrevocable Fund		Total PWR	Overtime Rate
			H&W	Pension	App Tr.	Vac.	Annuity	Other	LECET (*)	MISC (*)		
Classification												
Asbestos Insulation Mechanic	\$32.33		\$7.45	\$7.24	\$0.44	\$0.00	\$2.50	\$0.15	\$0.00	\$0.00	\$50.11	\$66.28
Firestop Technician	\$32.33		\$7.45	\$7.24	\$0.44	\$0.00	\$2.50	\$0.15	\$0.00	\$0.00	\$50.11	\$66.28
Apprentice	Percent											
1st year	52.83	\$17.08	\$7.21	\$0.00	\$0.40	\$0.00	\$0.00	\$0.15	\$0.00	\$0.00	\$24.84	\$33.38
2nd year	63.23	\$20.44	\$7.21	\$0.91	\$0.40	\$0.00	\$0.00	\$0.15	\$0.00	\$0.00	\$29.11	\$39.33
3rd year	72.65	\$23.49	\$7.21	\$1.81	\$0.40	\$0.00	\$0.30	\$0.15	\$0.00	\$0.00	\$33.36	\$45.10
4th year	83.05	\$26.85	\$7.21	\$1.81	\$0.40	\$0.00	\$0.30	\$0.15	\$0.00	\$0.00	\$36.72	\$50.15

Special Calculation Note : Other is Industry Fund.

Ratio :

4 Journeymen to 1 Apprentice Company Wide
except no apprentice may work on the jobsite without a
Mechanic

Jurisdiction (* denotes special jurisdictional note) :

ATHENS, AUGLAIZE, BUTLER*, CLINTON,
CRAWFORD, DELAWARE, FAIRFIELD, FAYETTE,
FRANKLIN, GUERNSEY, HARDIN, HOCKING,
KNOX, LICKING, LOGAN, MADISON, MARION,
MORGAN, MORROW, MUSKINGUM, NOBLE,
PERRY, PICKAWAY, ROSS, SHELBY, UNION,
VINTON, WARREN*

Special Jurisdictional Note : Township of Butler County-Townships of Lemon and Madison. Warren County-Township of Cleer Creek, Franklin, Massie, Turtle Creek and Wayne

Details :

Prevailing Wage Rate Skilled Crafts

Name of Union: Asbestos Local 8 Heat & Frost Insulators

Change # : LCN01-2020fbAsbLoc8

Craft : Asbestos Worker Effective Date : 03/01/2020 Last Posted : 02/26/2020

	BHR		Fringe Benefit Payments					Irrevocable Fund		Total PWR	Overtime Rate	
			H&W	Pension	App Tr.	Vac.	Annuity	Other	LECET (*)			MISC (*)
Classification												
Asbestos Insulators	\$30.07		\$6.89	\$9.35	\$0.41	\$0.00	\$2.10	\$0.00	\$0.00	\$0.00	\$48.82	\$63.86
Apprentice	Percent											
1st year	45.90	\$13.80	\$6.89	\$5.10	\$0.41	\$0.00	\$2.10	\$0.00	\$0.00	\$0.00	\$28.30	\$35.20
2nd year	53.20	\$16.00	\$6.89	\$6.65	\$0.41	\$0.00	\$2.10	\$0.00	\$0.00	\$0.00	\$32.05	\$40.05
3rd year	58.20	\$17.50	\$6.89	\$6.65	\$0.41	\$0.00	\$2.10	\$0.00	\$0.00	\$0.00	\$33.55	\$42.30
4th year	63.20	\$19.00	\$6.89	\$6.65	\$0.41	\$0.00	\$2.10	\$0.00	\$0.00	\$0.00	\$35.05	\$44.56

Special Calculation Note : No special calculations for this skilled craft wage rate are required at this time.

Ratio :

- 1 Journeymen to 1 Apprentice
- 2 Journeymen to 2 Apprentice
- 3 Journeymen to 3 Apprentice
- 3 Journeymen to 1 Apprentice there After

Jurisdiction (* denotes special jurisdictional note) :

ADAMS, BROWN, BUTLER*, CLERMONT, HAMILTON, HIGHLAND, WARREN*

Special Jurisdictional Note : In Butler County:townships of

Fairfield,Hanover,Liberty,Milford,Morgan,Oxford,Ripley,Ross,St.Clair,Union & Wayne. In Warren County: Townships of Deerfield,Hamilton,Harlan,Salem,Union & Washington

Details :

All work in connection with Asbestos Removal, Abatement, Encapsulation, Lead Abatement, Hazardous Materials and Fire Stopping which is performed by employees in the Mechanic or Apprentice Classification shall be covered under the terms of this Agreement.

Prevailing Wage Rate Skilled Crafts

Name of Union: Asbestos Local 207 OH

Change # : LCN01-2018fbLoc207OH

Craft : Asbestos Worker Effective Date : 08/23/2018 Last Posted : 08/23/2018

	BHR	Fringe Benefit Payments						Irrevocable Fund		Total PWR	Overtime Rate
		H&W	Pension	App Tr.	Vac.	Annuity	Other	LECET (*)	MISC (*)		
Classification											
Asbestos Abatement	\$25.50	\$7.25	\$6.45	\$0.65	\$0.00	\$0.00	\$0.07	\$0.00	\$0.00	\$39.92	\$52.67
Trainee	\$16.50	\$7.25	\$1.50	\$0.65	\$0.00	\$0.00	\$0.07	\$0.00	\$0.00	\$25.97	\$34.22

Special Calculation Note :

Ratio :

3 Journeymen to 1 Trainee

Jurisdiction (* denotes special jurisdictional note) :

ADAMS, ASHLAND, ASHTABULA*, ATHENS, AUGLAIZE, BROWN, BUTLER*, CARROLL, CHAMPAIGN, CLARK, CLERMONT, CLINTON, COLUMBIANA, COSHOCTON, CRAWFORD, CUYAHOGA, DARKE, DELAWARE, FAIRFIELD, FAYETTE, FRANKLIN, GEAUGA, GREENE, GUERNSEY, HAMILTON, HARDIN, HARRISON, HIGHLAND, HOCKING, HOLMES, HURON, KNOX, LAKE, LICKING, LOGAN, LORAIN, MADISON, MAHONING, MARION, MEDINA, MIAMI, MONTGOMERY, MORGAN, MORROW, MUSKINGUM, NOBLE, PERRY, PICKAWAY, PORTAGE, PREBLE, RICHLAND, ROSS, SHELBY, STARK, SUMMIT, TRUMBULL, TUSCARAWAS, UNION, VINTON, WARREN*, WAYNE

Special Jurisdictional Note : Butler County:(townships of Fairfield,Hanover,Liberty,Milford,Morgan,Oxford,Ripley,Ross,StClair,Union & Wayne.) (Lemon & Madison) Warren County: (townships of: Deerfield, Hamilton, Harlan, Salem, Union & Washington). (Clear Creek, Franklin, Mossie, Turtle Creek & Wayne). Ashtabula County: (post offices & townships of Ashtabula, Austinburg, Geneva, Harperfield, Jefferson, Plymouth & Saybrook) (townships of Andover, Cherry Valley, Colbrook, Canneaut, Denmark, Dorset, East Orwell, Hartsgrove, Kingville, Lenox, Monroe,Morgan,New Lyme,North Kingsville, Orwell, Pierpoint, Richmond Rock Creek, Rome, Sheffield, Trumbull, Wayne, Williamsfield & Windsor) Erie County:(post offices & townships of Berlin, Berlin Heights,Birmingham,Florence ,Huron, Milan, Shinrock & Vermillion)

Details :

Asbestos & lead paint abatement including, but not limited to the removal or encapsulation of asbestos & lead paint, all work in conjunction with the preparation of the removal of same & all work in conjunction with the clean up after said removal. The removal of all insulation materials, whether they contain asbestos or not, from mechanical systems (pipes, boilers, ducts, flues, breaching, etc.) is recognized as being the exclusive work of the Asbestos Abatement Workers.

On all mechanical systems (pipes, boilers, ducts, flues, breaching, etc.) that are going to be demolished, the removal of all insulating materials whether they contain asbestos or not shall be the exclusive work of the Laborers. An Abatement Journeyman is anyone who has more than 300 hours in the Asbestos Abatement field.

Prevailing Wage Rate Skilled Crafts

Name of Union: Boilermaker Local 105

Change # : LCN02-2013fbLoc 105

Craft : Boilermaker Effective Date : 10/01/2013 Last Posted : 09/25/2013

	BHR		Fringe Benefit Payments					Irrevocable Fund		Total PWR	Overtime Rate	
			H&W	Pension	App Tr.	Vac.	Annuity	Other	LECET (*)			MISC (*)
Classification												
Boilermaker	\$35.26		\$7.07	\$13.28	\$0.89	\$0.00	\$3.00	\$0.55	\$0.00	\$0.00	\$60.05	\$77.68
Apprentice	Percent											
1st 6 months	70.03	\$24.69	\$7.07	\$11.30	\$0.89	\$0.00	\$2.10	\$0.55	\$0.00	\$0.00	\$46.60	\$58.95
2nd 6 months	75.02	\$26.45	\$7.07	\$11.30	\$0.89	\$0.00	\$2.25	\$0.55	\$0.00	\$0.00	\$48.51	\$61.74
3rd 6 months	80.00	\$28.21	\$7.07	\$11.30	\$0.89	\$0.00	\$2.40	\$0.55	\$0.00	\$0.00	\$50.42	\$64.52
4th 6 months	85.02	\$29.98	\$7.07	\$11.30	\$0.89	\$0.00	\$2.55	\$0.55	\$0.00	\$0.00	\$52.34	\$67.33
5th 6 months	87.52	\$30.86	\$7.07	\$13.28	\$0.89	\$0.00	\$2.63	\$0.55	\$0.00	\$0.00	\$55.28	\$70.71
6th 6 months	90.03	\$31.74	\$7.07	\$13.28	\$0.89	\$0.00	\$2.70	\$0.55	\$0.00	\$0.00	\$56.23	\$72.11
7th 6 months	92.50	\$32.62	\$7.07	\$13.28	\$0.89	\$0.00	\$2.78	\$0.55	\$0.00	\$0.00	\$57.19	\$73.49
8th 6 months	95.00	\$33.50	\$7.07	\$13.28	\$0.89	\$0.00	\$2.85	\$0.55	\$0.00	\$0.00	\$58.14	\$74.89

Special Calculation Note : Other is Supplemental Health and Welfare

Ratio :

5 Journeymen to 1 Apprentice

Jurisdiction (* denotes special jurisdictional note) :

ADAMS, ATHENS, BROWN, BUTLER, CHAMPAIGN, CLARK, CLERMONT, CLINTON, FAIRFIELD, FAYETTE, FRANKLIN, GALLIA, GREENE, GUERNSEY, HAMILTON, HIGHLAND, HOCKING, JACKSON, LAWRENCE, LICKING, MADISON, MEIGS, MIAMI, MONTGOMERY, MORGAN, MUSKINGUM, NOBLE, PERRY, PICKAWAY, PIKE, PREBLE, ROSS, SCIOTO, VINTON, WARREN

Special Jurisdictional Note :

Details :

Prevailing Wage Rate Skilled Crafts

Name of Union: Boilermaker Local 154

Change # : LCN01-2012kpLoc 154

Craft : Boilermaker Effective Date : 03/22/2012 Last Posted : 03/22/2012

	BHR		Fringe Benefit Payments					Irrevocable Fund		Total PWR	Overtime Rate	
			H&W	Pension	App Tr.	Vac.	Annuity	Other	LECET (*)	MISC (*)		
Classification												
Boilermaker	\$36.17		\$8.57	\$11.28	\$0.55	\$0.00	\$4.25	\$0.34	\$0.00	\$1.40	\$62.56	\$80.65
Trainee 60%	\$23.25		\$8.57	\$3.59	\$0.55	\$0.00	\$4.25	\$0.34	\$0.00	\$1.40	\$41.95	\$53.57
Trainee 70%	\$27.13		\$8.57	\$3.59	\$0.55	\$0.00	\$4.25	\$0.34	\$0.00	\$1.40	\$45.83	\$59.40
Trainee 80%	\$31.00		\$8.57	\$3.59	\$0.55	\$0.00	\$4.25	\$0.34	\$0.00	\$1.40	\$49.70	\$65.20
Trainee 90%	\$34.88		\$8.57	\$3.59	\$0.55	\$0.00	\$4.25	\$0.34	\$0.00	\$1.40	\$53.58	\$71.02
Apprentice Registered After 11/01/2005	Percent											
1st 6 months	60.00	\$21.70	\$8.57	\$3.59	\$0.55	\$0.00	\$4.25	\$0.34	\$0.00	\$1.40	\$40.40	\$51.25
2nd 6 months	65.00	\$23.51	\$8.57	\$3.59	\$0.55	\$0.00	\$4.25	\$0.34	\$0.00	\$1.40	\$42.21	\$53.97
3rd 6 months	70.00	\$25.32	\$8.57	\$3.59	\$0.55	\$0.00	\$4.25	\$0.34	\$0.00	\$1.40	\$44.02	\$56.68
4th 6 months	75.00	\$27.13	\$8.57	\$3.59	\$0.55	\$0.00	\$4.25	\$0.34	\$0.00	\$1.40	\$45.83	\$59.39
5th 6 months	80.00	\$28.94	\$8.57	\$3.59	\$0.55	\$0.00	\$4.25	\$0.34	\$0.00	\$1.40	\$47.64	\$62.10
6th 6 months	85.00	\$30.74	\$8.57	\$3.59	\$0.55	\$0.00	\$4.25	\$0.34	\$0.00	\$1.40	\$49.44	\$64.82
7th 6 months	90.00	\$32.55	\$8.57	\$3.59	\$0.55	\$0.00	\$4.25	\$0.34	\$0.00	\$1.40	\$51.25	\$67.53
8th 6 months	95.00	\$34.36	\$8.57	\$3.59	\$0.55	\$0.00	\$4.25	\$0.34	\$0.00	\$1.40	\$53.06	\$70.24

Special Calculation Note : No special calculations for this skilled craft wage rate are required at this time.

Ratio :
5 Journeymen to 1 Apprentice

Jurisdiction (* denotes special jurisdictional note) :
BUTLER, COLUMBIANA, FAYETTE, JEFFERSON,
LAWRENCE, MERCER, WARREN, WASHINGTON

Special Jurisdictional Note :

Details :

Work includes but not limited to: boiler making, acetylene burning, riveting, chipping, caulking, rigging, fitting-up, grinding, reaming, impact machine operating, unloading, and handling of boilermaker's material and equipment. Boilermakers, Blacksmiths, Forgers, Iron Shipbuilders

Prevailing Wage Rate Skilled Crafts

Name of Union: Bricklayer Local 18

Change # : LCN01-2019fbLoc18

Craft : Bricklayer Effective Date : 06/05/2019 Last Posted : 06/05/2019

Classification	BHR		Fringe Benefit Payments					Irrevocable Fund		Total PWR	Overtime Rate	
			H&W	Pension	App Tr.	Vac.	Annuity	Other	LECET (*)			MISC (*)
Bricklayer	\$28.66		\$8.75	\$5.38	\$0.53	\$0.00	\$0.00	\$0.00	\$0.00	\$0.00	\$43.32	\$57.65
Stone Mason	\$28.66		\$8.75	\$5.38	\$0.53	\$0.00	\$0.00	\$0.00	\$0.00	\$0.00	\$43.32	\$57.65
Pointer Caulker Cleaner	\$28.66		\$8.75	\$5.38	\$0.53	\$0.00	\$0.00	\$0.00	\$0.00	\$0.00	\$43.32	\$57.65
Refractory Workers	\$29.66		\$8.75	\$5.38	\$0.52	\$0.00	\$0.00	\$0.00	\$0.00	\$0.00	\$44.31	\$59.14
Refractory Worker Hot Pay	\$31.66		\$8.75	\$5.38	\$0.52	\$0.00	\$0.00	\$0.00	\$0.00	\$0.00	\$46.31	\$62.14
Sawman	\$28.91		\$8.75	\$5.38	\$0.53	\$0.00	\$0.00	\$0.00	\$0.00	\$0.00	\$43.57	\$58.03
Layout Man	\$28.91		\$8.75	\$5.38	\$0.53	\$0.00	\$0.00	\$0.00	\$0.00	\$0.00	\$43.57	\$58.03
Free Standing Chimney	\$29.16		\$8.75	\$5.38	\$0.53	\$0.00	\$0.00	\$0.00	\$0.00	\$0.00	\$43.82	\$58.40
Apprentice	Percent											
1st 6 months	60.00	\$17.20	\$8.75	\$5.38	\$0.53	\$0.00	\$0.00	\$0.00	\$0.00	\$0.00	\$31.86	\$40.45
2nd 6 months	65.00	\$18.63	\$8.75	\$5.38	\$0.53	\$0.00	\$0.00	\$0.00	\$0.00	\$0.00	\$33.29	\$42.60
3rd 6 months	70.00	\$20.06	\$8.75	\$5.38	\$0.53	\$0.00	\$0.00	\$0.00	\$0.00	\$0.00	\$34.72	\$44.75
4th 6 months	75.00	\$21.50	\$8.75	\$5.38	\$0.53	\$0.00	\$0.00	\$0.00	\$0.00	\$0.00	\$36.16	\$46.90
5th 6 months	80.00	\$22.93	\$8.75	\$5.38	\$0.53	\$0.00	\$0.00	\$0.00	\$0.00	\$0.00	\$37.59	\$49.05
6th 6 months	85.00	\$24.36	\$8.75	\$5.38	\$0.53	\$0.00	\$0.00	\$0.00	\$0.00	\$0.00	\$39.02	\$51.20
7th 6 months	90.00	\$25.79	\$8.75	\$5.38	\$0.53	\$0.00	\$0.00	\$0.00	\$0.00	\$0.00	\$40.45	\$53.35
8th 6 months	95.00	\$27.23	\$8.75	\$5.38	\$0.53	\$0.00	\$0.00	\$0.00	\$0.00	\$0.00	\$41.89	\$55.50
MASON FINISHER 1st 180 Days	45.00	\$12.90	\$0.00	\$0.00	\$0.00	\$0.00	\$0.00	\$0.00	\$0.00	\$0.00	\$12.90	\$19.35
	45.00	\$12.90	\$8.75	\$0.00	\$0.00	\$0.00	\$0.00	\$0.00	\$0.00	\$0.00	\$21.65	\$28.10

1st Year H&W after 6 months												
2nd Year	50.00	\$14.33	\$8.75	\$0.00	\$0.00	\$0.00	\$0.00	\$0.00	\$0.00	\$0.00	\$23.08	\$30.25

Special Calculation Note : **In order to utilize a Pre-Apprentice, you must have 1 Registered Apprentice in your employ.

Ratio :

- 1-2 Journeyman to 1 Apprentice
- 3-4 Journeyman to 2 Apprentice
- 5-6 Journeyman to 2 Apprentice
- 7-10 Journeyman to 3 Apprentice

- 1 Apprentice permits 1 Mason Trainee
- 2 Apprentice permits 1 Mason Trainee
- 3 Apprentice permits 2 Mason Trainees
- 4 Apprentice permits 2 Mason Trainees

For each additional 5 Journeyman to 1 Apprentice,
for every 3 additional Apprentices, 1 Mason Finisher
may be added

Jurisdiction (* denotes special jurisdictional note) :

BROWN, BUTLER, CLERMONT, HAMILTON,
PREBLE*, WARREN

Special Jurisdictional Note : In Preble County the following townships are included: (Dixon, Gasper, Graits, Israel, Lanier and Somers)

Details :

MASON FINISHER:duties shall be to work in all aspects of Masonry construction taking direction from the employer and the Journeyman Bricklayer & Stone Mason's working on the job. Mason Finisher's may work on job site only when a registered apprentice is on job and the ratios in table above will strictly be enforced.

Refractory work is classified as working with any of the following materials:

Acid brick, carbon black brick or carbon black block, firebrick grinding, plastics (with a gun) and any resinous cement.

Fifty cents (\$0.50) per hour above scale shall be paid to employees working on free standing industrial or institutional chimneys which are completely detached from any building structure.

Prevailing Wage Rate Skilled Crafts

Name of Union: Bricklayer Local 18 Tile Finisher

Change # : LCN01-2019fbLoc18

Craft : Bricklayer Effective Date : 09/04/2019 Last Posted : 09/04/2019

	BHR		Fringe Benefit Payments						Irrevocable Fund		Total PWR	Overtime Rate
			H&W	Pension	App Tr.	Vac.	Annuity	Other	LECET (*)	MISC (*)		
Classification												
Bricklayer Tile Marble Terrazzo Finisher	\$24.69		\$9.22	\$5.10	\$0.50	\$0.00	\$0.00	\$0.00	\$0.00	\$0.00	\$39.51	\$51.86
Terrazzo Base Grinder	\$25.19		\$9.22	\$5.10	\$0.50	\$0.00	\$0.00	\$0.00	\$0.00	\$0.00	\$40.01	\$52.61
Marble Sander Polisher	\$24.79		\$9.22	\$5.10	\$0.50	\$0.00	\$0.00	\$0.00	\$0.00	\$0.00	\$39.61	\$52.01
Apprentices												
	Percent											
1st 6 months 0-600 hrs	60.00	\$14.81	\$9.22	\$5.10	\$0.50	\$0.00	\$0.00	\$0.00	\$0.00	\$0.00	\$29.63	\$37.04
2nd 6 months 601-1200 hrs	65.00	\$16.05	\$9.22	\$5.10	\$0.50	\$0.00	\$0.00	\$0.00	\$0.00	\$0.00	\$30.87	\$38.89
3rd 6 months 1201-1800 hrs	70.00	\$17.28	\$9.22	\$5.10	\$0.50	\$0.00	\$0.00	\$0.00	\$0.00	\$0.00	\$32.10	\$40.74
4th 6 months 1801-2400 hrs	75.00	\$18.52	\$9.22	\$5.10	\$0.50	\$0.00	\$0.00	\$0.00	\$0.00	\$0.00	\$33.34	\$42.60
5th 6 months 2401-3000 hrs	80.00	\$19.75	\$9.22	\$5.10	\$0.50	\$0.00	\$0.00	\$0.00	\$0.00	\$0.00	\$34.57	\$44.45
6th 6 months 3001-3600	90.00	\$22.22	\$9.22	\$5.10	\$0.50	\$0.00	\$0.00	\$0.00	\$0.00	\$0.00	\$37.04	\$48.15
1-30 Days Prior to Entering Apprenticeship	50.00	\$12.35	\$0.00	\$0.00	\$0.00	\$0.00	\$0.00	\$0.00	\$0.00	\$0.00	\$12.35	\$18.52

Special Calculation Note : Classification title contains "Bricklayer" because contract originates within the Bricklayer Local.

Note that the classification description is clarified after the local union number at the top of the page. **In order to utilize a Pre-Apprentice, you must have 1 Registered Apprentice in your employ.**

Ratio :

- 1 Journeyman to 1 Apprentice
- 5 Journeymen to 1 Apprentice
- 10 Journeymen to 2 Apprentices
- 15 Journeymen to 3 Apprentices
- 20 Journeymen to 4 Apprentices
- 25 Journeymen to 5 Apprentices

Jurisdiction (* denotes special jurisdictional note) :

- ADAMS, BROWN, BUTLER, CLERMONT, GALLIA,
- HAMILTON, LAWRENCE, PREBLE*, SCIOTO,
- WARREN, WARREN*

Special Jurisdictional Note : Warren in the townships of Dixon, Gasper, Isrsel, Somers & Gratis in Prebble County

Details :

Prevailing Wage Rate Skilled Crafts

Name of Union: Bricklayer Local 18 Tile Mechanic

Change # : LCN01-2019fbLoc18

Craft : Bricklayer Effective Date : 09/04/2019 Last Posted : 09/04/2019

	BHR	Fringe Benefit Payments						Irrevocable Fund		Total PWR	Overtime Rate
		H&W	Pension	App Tr.	Vac.	Annuity	Other	LECET (*)	MISC (*)		
Classification											
Bricklayer Tile Terrazzo Marble Mason Mechanic	\$29.24	\$9.22	\$5.10	\$0.54	\$0.00	\$0.00	\$0.00	\$0.00	\$0.00	\$44.10	\$58.72
Marble Layout Work	\$29.74	\$9.22	\$5.10	\$0.54	\$0.00	\$0.00	\$0.00	\$0.00	\$0.00	\$44.60	\$59.47
Swing Scaffold Worker	\$30.74	\$9.22	\$5.10	\$0.54	\$0.00	\$0.00	\$0.00	\$0.00	\$0.00	\$45.60	\$60.97
Apprentice after 2 years (2400 hrs) as Apprentice Finisher											
5th/6 Months 0-600 hrs.	70.00	\$20.47	\$9.22	\$5.10	\$0.54	\$0.00	\$0.00	\$0.00	\$0.00	\$35.33	\$45.56
6th/6 months 601-1200 hrs.	75.00	\$21.93	\$9.22	\$5.10	\$0.54	\$0.00	\$0.00	\$0.00	\$0.00	\$36.79	\$47.75
7th/6 months 1201-1800 hrs.	80.00	\$23.39	\$9.22	\$5.10	\$0.54	\$0.00	\$0.00	\$0.00	\$0.00	\$38.25	\$49.95
8th/6 months 1801-2400 hrs.	90.00	\$26.32	\$9.22	\$5.10	\$0.54	\$0.00	\$0.00	\$0.00	\$0.00	\$41.18	\$54.33

Special Calculation Note : Classification title contains "Bricklayer" because contract originates within the Bricklayer Local. Note that the classification description is clarified after the local union number at the top of the page.

Ratio :

- 1 Journeyman to 1 Apprentice
- 5 Journeymen to 1 Apprentice
- 10 Journeymen to 2 Apprentices
- 15 Journeymen to 3 Apprentices
- 20 Journeymen to 4 Apprentices
- 25 Journeymen to 5 Apprentices

Jurisdiction (* denotes special jurisdictional note) :

- ADAMS, BROWN, BUTLER, CLERMONT, GALLIA,
- HAMILTON, LAWRENCE, PREBLE*, SCIOTO, WARREN

Special Jurisdictional Note : In Preble County the Townships of Dixon, Israel, Gasper, Lanier, Somers and Gratis.

Details :

In order to utilize a Pre-Apprentice, you must have 1 Registered Apprentice in your employ.

Prevailing Wage Rate Skilled Crafts

Name of Union: Carpenter & Pile Driver SW District HevHwy

Change # : LCN01-2018fbLoc126

Craft : Carpenter Effective Date : 06/13/2018 Last Posted : 06/13/2018

	BHR		Fringe Benefit Payments					Irrevocable Fund		Total PWR	Overtime Rate	
			H&W	Pension	App Tr.	Vac.	Annuity	Other	LECET (*)			MISC (*)
Classification												
Carpenter	\$29.87		\$7.08	\$6.95	\$0.38	\$0.00	\$2.19	\$0.12	\$0.00	\$0.00	\$46.59	\$61.53
Pile Driver	\$29.34		\$6.63	\$6.95	\$0.40	\$0.00	\$1.97	\$0.10	\$0.00	\$0.00	\$45.39	\$60.06
Apprentice	Percent											
1st 6 Months	60.00	\$17.92	\$7.08	\$6.95	\$0.38	\$0.00	\$2.19	\$0.12	\$0.00	\$0.00	\$34.64	\$43.60
2nd 6 Months is 1st year	65.00	\$19.42	\$7.08	\$6.95	\$0.38	\$0.00	\$2.19	\$0.12	\$0.00	\$0.00	\$36.14	\$45.84
3rd 6 Months	70.00	\$20.91	\$7.08	\$6.95	\$0.38	\$0.00	\$2.19	\$0.12	\$0.00	\$0.00	\$37.63	\$48.08
4th 6 Months is 2 years	75.00	\$22.40	\$7.08	\$6.95	\$0.38	\$0.00	\$2.19	\$0.12	\$0.00	\$0.00	\$39.12	\$50.32
5th 6 Months	80.00	\$23.90	\$7.08	\$6.95	\$0.38	\$0.00	\$2.19	\$0.12	\$0.00	\$0.00	\$40.62	\$52.56
6th 6 Months is 3 years	85.00	\$25.39	\$7.08	\$6.95	\$0.38	\$0.00	\$2.19	\$0.12	\$0.00	\$0.00	\$42.11	\$54.80
7th 6 Months	90.00	\$26.88	\$7.08	\$6.95	\$0.38	\$0.00	\$2.19	\$0.12	\$0.00	\$0.00	\$43.60	\$57.04
8th 6 Months is 4 years	95.00	\$28.38	\$7.08	\$6.95	\$0.38	\$0.00	\$2.19	\$0.12	\$0.00	\$0.00	\$45.10	\$59.28

Special Calculation Note : Other is UBC National Fund.

Ratio :

1 Journeyman to 1 Apprentice

Jurisdiction (* denotes special jurisdictional note) :

BROWN, BUTLER, CHAMPAIGN, CLARK, CLERMONT, CLINTON, DARKE, GREENE, HAMILTON, LOGAN, MIAMI, MONTGOMERY, PREBLE, SHELBY, WARREN

An employer shall have the right to employ one (1) Apprentice for one (1) Journeyman Carpenter in its employment for the first Apprentice employed, and 1 (1) Apprentice for two (2) Journeyman Carpenter for additional Apprentices employed. Thereafter, every third additional carpenter hired shall be an apprentice, if available, and if practical for the type of work being performed.

Special Jurisdictional Note :

Details :

Highway Construction, Airport Construction, Heavy Construction but not limited to:(tunnels,subways,drainage projects,flood control,reservoirs). Railroad Construction,Sewer Waterworks & Utility Construction but not limited to: (storm sewers, waterlines, gaslines). Industrial & Building Site, Power Plant, Amusement Park, Athletic Stadium Site, Sewer and Water Plants. When the Contractor furnishes the necessary underwater gear for the Diver, the Diver shall be paid one and one half (1&1/2) times the journeyman rate for the time spent in the water.

Prevailing Wage Rate Skilled Crafts

Name of Union: Carpenter & Pile Driver
SW Zone 2

Change # : LCN01-2019fbLoc126

Craft : Carpenter Effective Date : 06/01/2019 Last Posted : 05/30/2019

	BHR		Fringe Benefit Payments						Irrevocable Fund		Total PWR	Overtime Rate
			H&W	Pension	App Tr.	Vac.	Annuity	Other	LECET (*)	MISC (*)		
Classification												
Carpenter	\$27.29		\$7.33	\$6.95	\$0.38	\$0.00	\$1.40	\$0.17	\$0.00	\$0.00	\$43.52	\$57.17
Pile Driver	\$25.84		\$6.62	\$6.95	\$0.40	\$0.00	\$0.91	\$0.10	\$0.00	\$0.00	\$40.82	\$53.74
Apprentice	Percent											
1st 3 Months	60.00	\$16.37	\$0.00	\$0.00	\$0.00	\$0.00	\$0.00	\$0.00	\$0.00	\$0.00	\$16.37	\$24.56
2nd 3 Months	60.00	\$16.37	\$7.33	\$0.00	\$0.38	\$0.00	\$1.40	\$0.17	\$0.00	\$0.00	\$25.65	\$33.84
2rd 6 Months	60.00	\$16.37	\$7.33	\$0.00	\$0.38	\$0.00	\$1.40	\$0.17	\$0.00	\$0.00	\$25.65	\$33.84
3rd 6 Months	65.00	\$17.74	\$7.33	\$0.00	\$0.38	\$0.00	\$1.40	\$0.17	\$0.00	\$0.00	\$27.02	\$35.89
4th 6 Months	65.00	\$17.74	\$7.33	\$0.00	\$0.38	\$0.00	\$1.40	\$0.17	\$0.00	\$0.00	\$27.02	\$35.89
5th 6 Months	70.00	\$19.10	\$7.33	\$6.95	\$0.38	\$0.00	\$1.40	\$0.17	\$0.00	\$0.00	\$35.33	\$44.88
6th 6 Months	75.00	\$20.47	\$7.33	\$6.95	\$0.38	\$0.00	\$1.40	\$0.17	\$0.00	\$0.00	\$36.70	\$46.93
7th 6 Months	80.00	\$21.83	\$7.33	\$6.95	\$0.38	\$0.00	\$1.40	\$0.17	\$0.00	\$0.00	\$38.06	\$48.98
8th 6 Months	85.00	\$23.20	\$7.33	\$6.95	\$0.38	\$0.00	\$1.40	\$0.17	\$0.00	\$0.00	\$39.43	\$51.02

Special Calculation Note : Other is for UBC National Fund.

Ratio :

- 1 Journeyman to 1 Apprentice
- 3 Journeyman to 1 Apprentice
- 5 Journeyman to 1 Apprentice

Jurisdiction (* denotes special jurisdictional note) :

BROWN, BUTLER, CLERMONT, CLINTON,
HAMILTON, WARREN

Special Jurisdictional Note :

Details :

Carpenter duties shall include but not limited to: Pile driving, milling, fashioning, joining, assembling, erecting, fastening, or dismantling of all material of

wood, plastic, metal, fiber, cork, and composition, and all other substitute materials: pile driving, cutting, fitting, and placing of lagging, and the handling, cleaning, erecting, installing, and dismantling of machinery, equipment, and erecting pre-engineered metal buildings.

Pile Drivers work but not limited to: unloading, assembling, erection, repairs, operation, signaling, dismantling, and reloading all equipment that is used for pile driving including pile butts. pile butts is defined as sheeting or scrap piling. Underwater work that may be required in connection with the installation of piling. The diver and his tender work as a team and shall arrive at their own financial arrangements with the contractor. Any configuration of wood, steel, concrete, or composite that is jetted, driven, or vibrated onto the ground by conventional pile driving equipment for the purpose of supporting a future load that may be permanent or temporary.

Driving bracing, plumbing, cutting off and capping of all piling whether wood, metal, pipe piling or composite. loading, unloading, erecting, framing, dismantling, moving, and handling of pile driving equipment. piling used in the construction and repair of all wharves, docks, piers, trestles, caissons, cofferdams, and the erection of all sea walls and breakwaters. All underwater and marine work on bulkheads, wharves, docks, shipyards, caissons, piers, bridges, pipeline work, viaducts, marine cable and trestles, as well as salvage and reclamation work where divers are employed.

Rate shall include carpenters, acoustic, and ceiling installers, drywall installers, pile drivers, and floorlayers.

Prevailing Wage Rate Skilled Crafts

Name of Union: Carpenter Floorlayer SW District G

Change # : LCR01-2019fbLocSWDayton

Craft : Carpenter Effective Date : 10/16/2019 Last Posted : 10/16/2019

	BHR		Fringe Benefit Payments					Irrevocable Fund		Total PWR	Overtime Rate	
			H&W	Pension	App Tr.	Vac.	Annuity	Other	LECET (*)			MISC (*)
Classification												
Carpenter Floorlayer	\$25.61		\$7.30	\$6.95	\$0.40	\$0.00	\$1.60	\$0.12	\$0.00	\$0.00	\$41.98	\$54.78
Apprentice	Percent											
1st 3 months	60.00	\$15.37	\$0.00	\$0.00	\$0.00	\$0.00	\$0.00	\$0.00	\$0.00	\$0.00	\$15.37	\$23.05
2nd 3 months	60.00	\$15.37	\$7.30	\$0.00	\$0.40	\$0.00	\$1.60	\$0.12	\$0.00	\$0.00	\$24.79	\$32.47
2nd 6 months	60.00	\$15.37	\$7.30	\$0.00	\$0.40	\$0.00	\$1.60	\$0.12	\$0.00	\$0.00	\$24.79	\$32.47
3rd 6 months	60.00	\$15.37	\$7.30	\$0.00	\$0.40	\$0.00	\$1.60	\$0.12	\$0.00	\$0.00	\$24.79	\$32.47
4th 6 months	65.00	\$16.65	\$7.30	\$0.00	\$0.40	\$0.00	\$1.60	\$0.12	\$0.00	\$0.00	\$26.07	\$34.39
5th 6 months	70.00	\$17.93	\$7.30	\$6.95	\$0.40	\$0.00	\$1.60	\$0.12	\$0.00	\$0.00	\$34.30	\$43.26
6th 6 months	75.00	\$19.21	\$7.30	\$6.95	\$0.40	\$0.00	\$1.60	\$0.12	\$0.00	\$0.00	\$35.58	\$45.18
7th 6 months	80.00	\$20.49	\$7.30	\$6.95	\$0.40	\$0.00	\$1.60	\$0.12	\$0.00	\$0.00	\$36.86	\$47.10
8th 6 months	85.00	\$21.77	\$7.30	\$6.95	\$0.40	\$0.00	\$1.60	\$0.12	\$0.00	\$0.00	\$38.14	\$49.02

Special Calculation Note : Other for \$0.12 is for UBC National Fund.

Ratio :

1 Journeymen to 1 Apprentice

Jurisdiction (* denotes special jurisdictional note) :

BROWN, BUTLER, CHAMPAIGN, CLARK, CLERMONT, CLINTON, DARKE, GREENE, HAMILTON, LOGAN, MIAMI, MONTGOMERY, PREBLE, SHELBY, WARREN

Special Jurisdictional Note :

Details :

Scope of work shall include, but not be limited to: receiving,unloading,handling,distribution and installation of all carpeting materials,carpet padding or matting materials and all resilient materials whether for use on walls, floors,counter, sink,table and all preparation work necessary in connection therewith, including sanding work. the installation of nonstructural under-layment and the work of removing, cleaning waxing of any of the above. Carpeting shall include any floor covering composed of either natural or synthetic fibers that are made in breadths to be sewed, fastened or directly glued to floors or over cushioning sound-proofing materials.Resilient Floors shall consist of and include the laying of all special designs of wood,wood block, wood composition, cork, linoleum, asphalt, mastic, plastic, rubber tile,whether nailed or glued.

Prevailing Wage Rate Skilled Crafts

Name of Union: Carpenter Millwright Local 1090 SW Zone I

Change # : LCN01-2018fbLoc1066

Craft : Carpenter Effective Date : 10/17/2018 Last Posted : 10/17/2018

	BHR		Fringe Benefit Payments					Irrevocable Fund		Total PWR	Overtime Rate	
			H&W	Pension	App Tr.	Vac.	Annuity	Other	LECET (*)			MISC (*)
Classification												
Carpenter Millwright	\$30.48		\$7.17	\$6.95	\$0.44	\$0.00	\$6.36	\$0.25	\$0.00	\$0.00	\$51.65	\$66.89
Apprentice	Percent											
1st 6 months	60.00	\$18.29	\$7.17	\$4.27	\$0.44	\$0.00	\$3.82	\$0.25	\$0.00	\$0.00	\$34.24	\$43.38
2nd 6 months	65.00	\$19.81	\$7.17	\$4.61	\$0.44	\$0.00	\$4.13	\$0.25	\$0.00	\$0.00	\$36.41	\$46.32
3rd 6 months	70.00	\$21.34	\$7.17	\$4.94	\$0.44	\$0.00	\$4.45	\$0.25	\$0.00	\$0.00	\$38.59	\$49.25
4th 6 months	75.00	\$22.86	\$7.17	\$5.28	\$0.44	\$0.00	\$4.77	\$0.25	\$0.00	\$0.00	\$40.77	\$52.20
5th 6 months	80.00	\$24.38	\$7.17	\$5.61	\$0.44	\$0.00	\$5.09	\$0.25	\$0.00	\$0.00	\$42.94	\$55.14
6th 6 months	85.00	\$25.91	\$7.17	\$5.95	\$0.44	\$0.00	\$5.41	\$0.25	\$0.00	\$0.00	\$45.13	\$58.08
7th 6 months	90.00	\$27.43	\$7.17	\$6.28	\$0.44	\$0.00	\$5.72	\$0.25	\$0.00	\$0.00	\$47.29	\$61.01
8th 6 months	95.00	\$28.96	\$7.17	\$6.62	\$0.44	\$0.00	\$6.04	\$0.25	\$0.00	\$0.00	\$49.48	\$63.95

Special Calculation Note : Other (\$0.25) \$0.10 National Fund, \$0.10. Drug Safety Program \$0.10 and National Millwright Fund \$0.05

Ratio :

3 Journeymen to 1 Apprentice

Jurisdiction (* denotes special jurisdictional note) :

BROWN, BUTLER, CLERMONT, CLINTON,
HAMILTON, WARREN

Special Jurisdictional Note :

Details :

Prevailing Wage Rate Skilled Crafts

Name of Union: Carpenter NE District Industrial Dock & Door

Change # : LCN01-2014fbCarpNEStatewide

Craft : Carpenter Effective Date : 03/05/2014 Last Posted : 03/05/2014

	BHR		Fringe Benefit Payments						Irrevocable Fund		Total PWR	Overtime Rate
			H&W	Pension	App Tr.	Vac.	Annuity	Other	LECET (*)	MISC (*)		
Classification												
Carpenter	\$19.70		\$5.05	\$1.00	\$0.15	\$0.00	\$0.00	\$0.00	\$0.00	\$0.00	\$25.90	\$35.75
Trainee												
	Percent											
1st Year	60.00	\$11.82	\$5.05	\$1.00	\$0.15	\$0.00	\$0.00	\$0.00	\$0.00	\$0.00	\$18.02	\$23.93
2nd Year	80.20	\$15.80	\$5.05	\$1.00	\$0.15	\$0.00	\$0.00	\$0.00	\$0.00	\$0.00	\$22.00	\$29.90

Special Calculation Note : No special calculations for this skilled craft wage rate are required at this time.

Ratio :

1 Journeymen to 1 Trainee

Jurisdiction (* denotes special jurisdictional note) :

ADAMS, ALLEN, ASHLAND, ASHTABULA, ATHENS, AUGLAIZE, BELMONT, BROWN, BUTLER, CARROLL, CHAMPAIGN, CLARK, CLERMONT, CLINTON, COLUMBIANA, COSHOCTON, CRAWFORD, CUYAHOGA, DARKE, DEFIANCE, DELAWARE, ERIE, FAIRFIELD, FAYETTE, FRANKLIN, FULTON, GALLIA, GEAUGA, GREENE, GUERNSEY, HAMILTON, HANCOCK, HARDIN, HARRISON, HENRY, HIGHLAND, HOCKING, HOLMES, HURON, JACKSON, JEFFERSON, KNOX, LAKE, LAWRENCE, LICKING, LOGAN, LORAIN, LUCAS, MADISON, MAHONING, MARION, MEDINA, MEIGS, MERCER, MIAMI, MONROE, MONTGOMERY, MORGAN, MORROW, MUSKINGUM, NOBLE, OTTAWA, PAULDING, PERRY, PICKAWAY, PIKE, PORTAGE, PREBLE, PUTNAM, RICHLAND, ROSS, SANDUSKY, SCIOTO, SENECA, SHELBY, STARK, SUMMIT, TRUMBULL, TUSCARAWAS, UNION, VAN WERT, VINTON, WARREN, WASHINGTON, WAYNE, WILLIAMS, WOOD, WYANDOT

Special Jurisdictional Note : Industrial Dock and Door is the installation of overhead doors, roll up doors and dock leveling equipment

Details :

10/27/10 New Contract jc

Prevailing Wage Rate Skilled Crafts

Name of Union: Cement Mason Bricklayer Local 97 HevHwy A

Change # : LCN01-2019fbHvyHwy

Craft : Bricklayer Effective Date : 06/01/2019 Last Posted : 05/29/2019

	BHR		Fringe Benefit Payments					Irrevocable Fund		Total PWR	Overtime Rate	
			H&W	Pension	App Tr.	Vac.	Annuity	Other	LECET (*)			MISC (*)
Classification												
Cement Mason Bricklayer Sewer Water Works A	\$29.34		\$9.25	\$6.41	\$0.45	\$0.00	\$0.00	\$0.00	\$0.00	\$0.00	\$45.45	\$60.12
Apprentice												
	Percent											
1st year	50.00	\$14.67	\$9.25	\$6.41	\$0.45	\$0.00	\$0.00	\$0.00	\$0.00	\$0.00	\$30.78	\$38.12
2nd year	70.00	\$20.54	\$9.25	\$6.41	\$0.45	\$0.00	\$0.00	\$0.00	\$0.00	\$0.00	\$36.65	\$46.92
3rd year	90.00	\$26.41	\$9.25	\$6.41	\$0.45	\$0.00	\$0.00	\$0.00	\$0.00	\$0.00	\$42.52	\$55.72

Special Calculation Note : NOT FOR BUILDING CONSTRUCTION.

Ratio :

- 3 Journeymen to 1 Apprentice
- 6 Journeymen to 2 Apprentice
- 9 Journeymen to 3 Apprentice
- 12 Journeymen to 4 Apprentice
- 15 Journeymen to 5 Apprentice

Jurisdiction (* denotes special jurisdictional note) :

ADAMS, ALLEN, ASHLAND, ASHTABULA, ATHENS, AUGLAIZE, BELMONT, BROWN, BUTLER, CARROLL, CHAMPAIGN, CLARK, CLERMONT, CLINTON, COLUMBIANA, COSHOCTON, CRAWFORD, CUYAHOGA, DARKE, DEFIANCE, DELAWARE, ERIE, FAIRFIELD, FAYETTE, FRANKLIN, FULTON, GALLIA, GEAUGA, GREENE, GUERNSEY, HAMILTON, HANCOCK, HARDIN, HARRISON, HENRY, HIGHLAND, HOCKING, HOLMES, HURON, JACKSON, JEFFERSON, KNOX, LAKE, LAWRENCE, LICKING, LOGAN, LORAIN, LUCAS, MADISON, MAHONING, MARION, MEDINA, MEIGS, MERCER, MIAMI, MONROE, MONTGOMERY, MORGAN, MORROW, MUSKINGUM, NOBLE, OTTAWA, PAULDING, PERRY, PICKAWAY, PIKE, PORTAGE, PREBLE, PUTNAM, RICHLAND, ROSS, SANDUSKY, SCIOTO, SENECA, SHELBY, STARK, SUMMIT, TRUMBULL, TUSCARAWAS, UNION, VAN WERT, VINTON, WARREN, WASHINGTON, WAYNE

Special Jurisdictional Note :

Details :

- (A) Highway Construction, Sewer, Waterworks And Utility Construction, Industrial & Building Site Heavy Construction, Airport Construction Or Railroad Construction Work.
- (B) Power Plant, Tunnels, Amusement Park, Athletic Stadium Site Work ,Pollution Control,Sewer Plant, Waste Plant, & Water Treatment Facilities, Construction.

Prevailing Wage Rate Skilled Crafts

Name of Union: Cement Mason Bricklayer Local 97 HevHwy B

Change # : LCN01-2019fbHvyHwy

Craft : Bricklayer Effective Date : 06/01/2019 Last Posted : 05/29/2019

	BHR	Fringe Benefit Payments						Irrevocable Fund		Total PWR	Overtime Rate
		H&W	Pension	App Tr.	Vac.	Annuity	Other	LECET (*)	MISC (*)		
Classification											
Cement Mason Bricklayer Power Plants Tunnels Amusement Parks B	\$30.33	\$9.25	\$6.41	\$0.46	\$0.00	\$0.00	\$0.00	\$0.00	\$0.00	\$46.45	\$61.62
Apprentice	Percent										
1st year	50.00	\$15.16	\$9.25	\$6.41	\$0.46	\$0.00	\$0.00	\$0.00	\$0.00	\$31.28	\$38.87
2nd year	70.00	\$21.23	\$9.25	\$6.41	\$0.46	\$0.00	\$0.00	\$0.00	\$0.00	\$37.35	\$47.97
3rd year	90.00	\$27.30	\$9.25	\$6.41	\$0.46	\$0.00	\$0.00	\$0.00	\$0.00	\$43.42	\$57.07

Special Calculation Note : NOT FOR BUILDING CONSTRUCTION.

Ratio :

- 3 Journeymen to 1 Apprentice
- 6 Journeymen to 2 Apprentice
- 9 Journeymen to 2 Apprentice
- 12 Journeymen to 4 Apprentice
- 15 Journeymen to 5 Apprentice

Jurisdiction (* denotes special jurisdictional note) :

ADAMS, ALLEN, ASHLAND, ASHTABULA, ATHENS, AUGLAIZE, BELMONT, BROWN, BUTLER, CARROLL, CHAMPAIGN, CLARK, CLERMONT, CLINTON, COLUMBIANA, COSHOCTON, CRAWFORD, CUYAHOGA, DARKE, DEFIANCE, DELAWARE, ERIE, FAIRFIELD, FAYETTE, FRANKLIN, FULTON, GALLIA, GEAUGA, GREENE, GUERNSEY, HAMILTON, HANCOCK, HARDIN, HARRISON, HENRY, HIGHLAND, HOCKING, HOLMES, HURON, JACKSON, JEFFERSON, KNOX, LAKE, LAWRENCE, LICKING, LOGAN, LORAIN, LUCAS, MADISON, MAHONING, MARION, MEDINA, MEIGS, MERCER, MIAMI, MONROE, MONTGOMERY, MORGAN, MORROW, MUSKINGUM, NOBLE, OTTAWA, PAULDING, PERRY, PICKAWAY, PIKE, PORTAGE, PREBLE, PUTNAM, RICHLAND, ROSS, SANDUSKY, SCIOTO, SENECA, SHELBY, STARK, SUMMIT, TRUMBULL, TUSCARAWAS, UNION, VAN WERT, VINTON, WARREN, WASHINGTON, WAYNE

Special Jurisdictional Note :

Details :

- (A) Highway Construction, Sewer, Waterworks And Utility Construction, Industrial & Building Site Heavy Construction, Airport Construction Or Railroad Construction Work.
- (B) Power Plant, Tunnels, Amusement Park, Athletic Stadium Site Work ,Pollution Control,Sewer Plant, Waste Plant, & Water Treatment Facilities, Construction.

Prevailing Wage Rate Skilled Crafts

Name of Union: Cement Mason Local 132 (Cincinnati)

Change # : LCN01-2019fbLoc132

Craft : Cement Effective Date : 06/05/2019 Last Posted : 06/05/2019

	BHR		Fringe Benefit Payments					Irrevocable Fund		Total PWR	Overtime Rate	
			H&W	Pension	App Tr.	Vac.	Annuity	Other	LECET (*)			MISC (*)
Classification												
Cement Mason	\$24.50		\$6.70	\$6.50	\$0.60	\$0.00	\$0.80	\$0.00	\$0.00	\$0.00	\$39.10	\$51.35
Apprentice	Percent											
1st yr	70.00	\$17.15	\$6.70	\$6.50	\$0.60	\$0.00	\$0.80	\$0.00	\$0.00	\$0.00	\$31.75	\$40.32
2nd yr	80.00	\$19.60	\$6.70	\$6.50	\$0.60	\$0.00	\$0.80	\$0.00	\$0.00	\$0.00	\$34.20	\$44.00
3rd yr	90.00	\$22.05	\$6.70	\$6.50	\$0.60	\$0.00	\$0.80	\$0.00	\$0.00	\$0.00	\$36.65	\$47.68

Special Calculation Note : No special calculations for this skilled craft wage rate are required at this time.

Ratio :

- 1 Journeymen to 1 Apprentice
- 4 Journeymen to 2 Apprentice
- 7 Journeymen to 3 Apprentice
- 10 Journeymen to 4 Apprentice

Jurisdiction (* denotes special jurisdictional note) :

BROWN, BUTLER, CLERMONT, HAMILTON,
HIGHLAND, WARREN

Special Jurisdictional Note :

Details :

- *Cement Masons working on silo & slip form work shall receive \$.50 per hour over Journeyman scale.
- *Cement Masons working on swinging scaffolds shall receive \$.50 per hour over Journeyman scale.
- *Cement Masons working on high lifts from 20' and above shall receive \$.50 per hour over Journeyman scale.

Prevailing Wage Rate Skilled Crafts

Name of Union: Cement Mason Statewide HevHwy Exhibit A District II

Change # : OCN01-2019fbCementHevHwy

Craft : Cement Mason Effective Date : 07/31/2019 Last Posted : 07/31/2019

	BHR		Fringe Benefit Payments						Irrevocable Fund		Total PWR	Overtime Rate
			H&W	Pension	App Tr.	Vac.	Annuity	Other	LECET (*)	MISC (*)		
Classification												
Cement Mason	\$29.36		\$8.00	\$6.90	\$0.71	\$0.00	\$2.25	\$0.00	\$0.00	\$0.00	\$47.22	\$61.90
Apprentice Percent												
1st Year	70.00	\$20.55	\$8.00	\$6.90	\$0.71	\$0.00	\$2.25	\$0.00	\$0.00	\$0.00	\$38.41	\$48.69
2nd Year	80.00	\$23.49	\$8.00	\$6.90	\$0.71	\$0.00	\$2.25	\$0.00	\$0.00	\$0.00	\$41.35	\$53.09
3rd Year	90.00	\$26.42	\$8.00	\$6.90	\$0.71	\$0.00	\$2.25	\$0.00	\$0.00	\$0.00	\$44.28	\$57.50

Special Calculation Note : No special calculations for this skilled craft wage rate are required at this time.

Ratio :

1 Journeymen to 1 Apprentice
2 to 1 thereafter

Jurisdiction (* denotes special jurisdictional note) :

BROWN, BUTLER, CLERMONT, COLUMBIANA, DEFIANCE, ERIE, HAMILTON, HIGHLAND, HURON, LORAIN, MAHONING, MEDINA, OTTAWA, PAULDING, PORTAGE, SANDUSKY, SENECA, STARK, SUMMIT, TRUMBULL, WARREN, WILLIAMS

Special Jurisdictional Note : (A) Highway Construction, Sewer, Waterworks And Utility Construction, Industrial & Building Site, Heavy Construction, Airport Construction Or Railroad Construction Work.

Details :

Prevailing Wage Rate Skilled Crafts

Name of Union: Cement Mason Statewide HevHwy Exhibit B District II

Change # : OCN01-2019fbCementHevHwy

Craft : Cement Mason Effective Date : 07/31/2019 Last Posted : 07/31/2019

	BHR		Fringe Benefit Payments						Irrevocable Fund		Total PWR	Overtime Rate
			H&W	Pension	App Tr.	Vac.	Annuity	Other	LECET (*)	MISC (*)		
Classification												
Cement Mason	\$30.23		\$8.00	\$6.90	\$0.71	\$0.00	\$2.25	\$0.00	\$0.00	\$0.00	\$48.09	\$63.21
Apprentice Percent												
1st Year	70.00	\$21.16	\$8.00	\$6.90	\$0.71	\$0.00	\$2.25	\$0.00	\$0.00	\$0.00	\$39.02	\$49.60
2nd Year	80.00	\$24.18	\$8.00	\$6.90	\$0.71	\$0.00	\$2.25	\$0.00	\$0.00	\$0.00	\$42.04	\$54.14
3rd Year	90.00	\$27.21	\$8.00	\$6.90	\$0.71	\$0.00	\$2.25	\$0.00	\$0.00	\$0.00	\$45.07	\$58.67

Special Calculation Note : No special calculations for this skilled craft wage rate are required at this time.

Ratio :

1 Journeymen to 1 Apprentice
2 to 1 thereafter

Jurisdiction (* denotes special jurisdictional note) :

BROWN, BUTLER, CLERMONT, COLUMBIANA, DEFIANCE, ERIE, HAMILTON, HIGHLAND, HURON, LORAIN, MAHONING, MEDINA, OTTAWA, PAULDING, PORTAGE, SANDUSKY, SENECA, STARK, SUMMIT, TRUMBULL, WARREN, WILLIAMS

Special Jurisdictional Note : (B) Power Plant, Tunnels, Amusement Park, Athletic Stadium Site Work ,Pollution Control,Sewer Plant, Waste Plant, & Water Treatment Facilities, Construction.

Details :

Prevailing Wage Rate Skilled Crafts

Name of Union: Electrical Local 71 High Tension Pipe Type Cable

Change # : LCN01-2019fbLoc7

Craft : Lineman Effective Date : 04/24/2019 Last Posted : 04/24/2019

Classification	BHR		Fringe Benefit Payments					Irrevocable Fund		Total PWR	Overtime Rate
			H&W	Pension	App Tr.	Vac.	Annuity	Other	LECET (*)		
Electrical Lineman	\$43.48	\$6.00	\$1.30	\$0.43	\$0.00	\$10.00	\$0.35	\$0.00	\$0.00	\$61.56	\$83.30
Certified Lineman Welder	\$43.48	\$6.00	\$1.30	\$0.43	\$0.00	\$10.00	\$0.35	\$0.00	\$0.00	\$61.56	\$83.30
Certified Cable Splicer	\$43.48	\$6.00	\$1.30	\$0.43	\$0.00	\$10.00	\$0.35	\$0.00	\$0.00	\$61.56	\$83.30
Operator A	\$39.02	\$6.00	\$1.17	\$0.39	\$0.00	\$8.97	\$0.35	\$0.00	\$0.00	\$55.90	\$75.41
Operator B	\$34.60	\$6.00	\$1.04	\$0.35	\$0.00	\$7.96	\$0.35	\$0.00	\$0.00	\$50.30	\$67.60
Operator C	\$27.93	\$6.00	\$0.84	\$0.28	\$0.00	\$6.42	\$0.35	\$0.00	\$0.00	\$41.82	\$55.79
Groundman 0-12 months Exp	\$21.74	\$6.00	\$0.65	\$0.22	\$0.00	\$5.00	\$0.35	\$0.00	\$0.00	\$33.96	\$44.83
Groundman 0-12 months Exp w/CDL	\$23.91	\$6.00	\$0.72	\$0.24	\$0.00	\$5.50	\$0.35	\$0.00	\$0.00	\$36.72	\$48.68
Groundman 1 yr or more	\$23.91	\$6.00	\$0.72	\$0.24	\$0.00	\$5.50	\$0.35	\$0.00	\$0.00	\$36.72	\$48.68
Groundman 1 yr or more w/CDL	\$28.26	\$6.00	\$0.85	\$0.28	\$0.00	\$6.50	\$0.35	\$0.00	\$0.00	\$42.24	\$56.37
Equipment Mechanic A	\$34.60	\$6.00	\$1.04	\$0.35	\$0.00	\$7.96	\$0.35	\$0.00	\$0.00	\$50.30	\$67.60
Equipment Mechanic B	\$31.26	\$6.00	\$0.94	\$0.31	\$0.00	\$7.19	\$0.35	\$0.00	\$0.00	\$46.05	\$61.68
Equipment Mechanic C	\$27.93	\$6.00	\$0.84	\$0.28	\$0.00	\$6.42	\$0.35	\$0.00	\$0.00	\$41.82	\$55.79
X-Ray Technician	\$43.48	\$6.00	\$1.30	\$0.43	\$0.00	\$10.00	\$0.35	\$0.00	\$0.00	\$61.56	\$83.30
Apprentice	Percent										
1st 1000 hrs	60.00	\$26.09	\$6.00	\$0.78	\$0.26	\$0.00	\$6.00	\$0.35	\$0.00	\$39.48	\$52.52

2nd 1000 hrs	65.00	\$28.26	\$6.00	\$0.85	\$0.28	\$0.00	\$6.50	\$0.35	\$0.00	\$0.00	\$42.24	\$56.37
3rd 1000 hrs	70.00	\$30.44	\$6.00	\$0.91	\$0.30	\$0.00	\$7.00	\$0.35	\$0.00	\$0.00	\$45.00	\$60.21
4th 1000 hrs	75.00	\$32.61	\$6.00	\$0.98	\$0.33	\$0.00	\$7.50	\$0.35	\$0.00	\$0.00	\$47.77	\$64.07
5th 1000 hrs	80.00	\$34.78	\$6.00	\$1.04	\$0.35	\$0.00	\$8.00	\$0.35	\$0.00	\$0.00	\$50.52	\$67.92
6th 1000 hrs	85.00	\$36.96	\$6.00	\$1.11	\$0.37	\$0.00	\$8.50	\$0.35	\$0.00	\$0.00	\$53.29	\$71.77
7th 1000 hrs	90.00	\$39.13	\$6.00	\$1.17	\$0.39	\$0.00	\$9.00	\$0.35	\$0.00	\$0.00	\$56.04	\$75.61

Special Calculation Note : Other is Health Retirement Account

Operator "A"

John Henry Rock Drill, D-6 (or equivalent) and above, Trackhoe Digger, (320 Track excavator), Cranes (greater than 25 tons and less than 45 tons).

Operator "B"

Cranes (greater than 6 tons and up to 25 tons), Backhoes, Road Tractor, Dozer up to D-5, Pressure Digger- wheeled or tracked, all Tension wire Stringing equipment.

Operator "C"

Trench, Backhoe, Riding type vibratory Compactor, Ground Rod Driver, Boom Truck (6 ton & below), Skid Steer Loaders, Material Handler.

*All Operators of cranes 45 ton or larger shall be paid the journeyman rate of pay. \$0.30 is for Health Retirement Account.

Ratio :

1 Journeyman to 1 Apprentice

Jurisdiction (* denotes special jurisdictional note) :

ADAMS, ASHLAND, ASHTABULA, ATHENS, AUGLAIZE, BELMONT, BROWN, BUTLER, CARROLL, CHAMPAIGN, CLARK, CLERMONT, CLINTON, COLUMBIANA, COSHOCTON, CRAWFORD, CUYAHOGA, DARKE, DELAWARE, FAIRFIELD, FAYETTE, FRANKLIN, GALLIA, GEauga, GREENE, GUERNSEY, HAMILTON, HARRISON, HIGHLAND, HOCKING, HOLMES, JACKSON, JEFFERSON, KNOX, LAKE, LAWRENCE, LICKING, LOGAN, LORAIN, MADISON, MAHONING, MARION, MEDINA, MEIGS, MERCER, MIAMI, MONROE, MONTGOMERY, MORGAN, MORROW, MUSKINGUM, NOBLE, PERRY, PICKAWAY, PIKE, PORTAGE, PREBLE, RICHLAND, ROSS, SCIOTO, SHELBY, STARK, SUMMIT, TRUMBULL, TUSCARAWAS, UNION, VINTON, WARREN, WASHINGTON, WAYNE

Special Jurisdictional Note :

Details :

Heli - Arc Welding will be paid \$.30 above Journeyman rate. Additional compensation of 10% over the Journeyman Lineman and Journeyman Technician for performing work on structures outside of buildings such as water towers, smoke stacks, radio and television towers, more than 75' above the ground.

1st 1,000 Hours	60.00	\$22.96	\$6.00	\$0.69	\$0.23	\$0.00	\$4.13	\$0.06	\$0.00	\$0.00	\$34.07	\$45.55
2nd 1,000 Hours	65.00	\$24.88	\$6.00	\$0.75	\$0.25	\$0.00	\$4.48	\$0.06	\$0.00	\$0.00	\$36.42	\$48.85
3rd 1,000 Hours	70.00	\$26.79	\$6.00	\$0.80	\$0.27	\$0.00	\$4.82	\$0.06	\$0.00	\$0.00	\$38.74	\$52.13
4th 1,000 Hours	75.00	\$28.70	\$6.00	\$0.86	\$0.29	\$0.00	\$5.17	\$0.06	\$0.00	\$0.00	\$41.08	\$55.43
5th 1,000 Hours	80.00	\$30.62	\$6.00	\$0.92	\$0.31	\$0.00	\$5.51	\$0.06	\$0.00	\$0.00	\$43.42	\$58.72
6th 1,000 Hours	85.00	\$32.53	\$6.00	\$0.98	\$0.33	\$0.00	\$5.86	\$0.06	\$0.00	\$0.00	\$45.76	\$62.02
7th 1,000 Hours	90.00	\$34.44	\$6.00	\$1.03	\$0.34	\$0.00	\$6.20	\$0.06	\$0.00	\$0.00	\$48.07	\$65.29

Special Calculation Note : Other is Safety & Education Fund.

Ratio :

1 Journeymen to 1 Apprentice

Jurisdiction (* denotes special jurisdictional note) :

BROWN, BUTLER, CLERMONT, HAMILTON, WARREN

Special Jurisdictional Note :

Details :

A groundman when directed shall assist a Journeyman in the performance of his/her work on the ground, including the use of hand tools. A Groundman under no circumstances shall climb poles, towers, ladders, or work from an elevated platform or bucket truck.

No more than three (3) Groundmen shall work alone. Jobs with more than three Groundmen shall be supervised by a Groundcrew Foreman, Journeyman Lineman, Journeyman Traffic Signal Technician or an Equipment Operator.

Scope of Work: installation and maintenance of highway and street lighting, highway and street sign lighting, electronic message boards and traffic control systems, camera systems, traffic signal work, substation and line construction including overhead and underground projects for private and industrial work as in accordance with the IBEW Constitution. This Agreement includes the operation of all tools and equipment necessary for the installation of the above projects.

Prevailing Wage Rate Skilled Crafts

Name of Union: Electrical Local 71 Outside Utility Power

Change # : LCN01-2019fbLoc7

Craft : Lineman Effective Date : 04/24/2019 Last Posted : 04/24/2019

Classification	BHR	Fringe Benefit Payments						Irrevocable Fund		Total PWR	Overtime Rate	
		H&W	Pension	App Tr.	Vac.	Annuity	Other	LECET (*)	MISC (*)			
Electrical Lineman	\$41.22	\$6.00	\$1.24	\$0.41	\$0.00	\$9.48	\$0.35	\$0.00	\$0.00	\$58.70	\$79.31	
Substation Technician	\$41.22	\$6.00	\$1.24	\$0.41	\$0.00	\$9.48	\$0.35	\$0.00	\$0.00	\$58.70	\$79.31	
Cable Splicer	\$43.14	\$6.00	\$1.29	\$0.43	\$0.00	\$9.92	\$0.35	\$0.00	\$0.00	\$61.13	\$82.70	
Operator A	\$37.00	\$6.00	\$1.11	\$0.37	\$0.00	\$8.51	\$0.35	\$0.00	\$0.00	\$53.34	\$71.84	
Operator B	\$32.78	\$6.00	\$0.98	\$0.33	\$0.00	\$7.54	\$0.35	\$0.00	\$0.00	\$47.98	\$64.37	
Operator C	\$26.44	\$6.00	\$0.79	\$0.26	\$0.00	\$6.08	\$0.35	\$0.00	\$0.00	\$39.92	\$53.14	
Groundman 0-12 months Exp	\$20.61	\$6.00	\$0.62	\$0.21	\$0.00	\$4.74	\$0.35	\$0.00	\$0.00	\$32.53	\$42.84	
Groundman 0-12 months Exp w/CDL	\$22.67	\$6.00	\$0.68	\$0.23	\$0.00	\$5.21	\$0.35	\$0.00	\$0.00	\$35.14	\$46.48	
Groundman 1 yr or more	\$22.67	\$6.00	\$0.68	\$0.23	\$0.00	\$5.21	\$0.35	\$0.00	\$0.00	\$35.14	\$46.48	
Groundman 1 yr or more w/CDL	\$26.80	\$6.00	\$0.80	\$0.27	\$0.00	\$6.16	\$0.35	\$0.00	\$0.00	\$40.38	\$53.78	
Equipment Mechanic A	\$32.78	\$6.00	\$0.98	\$0.33	\$0.00	\$7.54	\$0.35	\$0.00	\$0.00	\$47.98	\$64.37	
Equipment Mechanic B	\$29.62	\$6.00	\$0.89	\$0.30	\$0.00	\$6.81	\$0.35	\$0.00	\$0.00	\$43.97	\$58.78	
Equipment Mechanic C	\$26.44	\$6.00	\$0.79	\$0.26	\$0.00	\$6.08	\$0.35	\$0.00	\$0.00	\$39.92	\$53.14	
Line Truck w/uuger	\$29.17	\$6.00	\$0.88	\$0.29	\$0.00	\$6.71	\$0.35	\$0.00	\$0.00	\$43.40	\$57.99	
Apprentice	Percent											
1st 1000 hrs	60.00	\$24.73	\$6.00	\$0.74	\$0.25	\$0.00	\$5.69	\$0.35	\$0.00	\$0.00	\$37.76	\$50.13

2nd 1000 hrs	65.00	\$26.79	\$6.00	\$0.80	\$0.27	\$0.00	\$6.16	\$0.35	\$0.00	\$0.00	\$40.37	\$53.77
3rd 1000 hrs	70.00	\$28.85	\$6.00	\$0.87	\$0.29	\$0.00	\$6.64	\$0.35	\$0.00	\$0.00	\$43.00	\$57.43
4th 1000 hrs	75.00	\$30.91	\$6.00	\$0.93	\$0.31	\$0.00	\$7.11	\$0.35	\$0.00	\$0.00	\$45.62	\$61.07
5th 1000 hrs	80.00	\$32.98	\$6.00	\$0.99	\$0.33	\$0.00	\$7.59	\$0.35	\$0.00	\$0.00	\$48.24	\$64.72
6th 1000 hrs	85.00	\$35.04	\$6.00	\$1.05	\$0.35	\$0.00	\$8.06	\$0.35	\$0.00	\$0.00	\$50.85	\$68.37
7th 1000 hrs	90.00	\$37.10	\$6.00	\$1.11	\$0.37	\$0.00	\$8.53	\$0.35	\$0.00	\$0.00	\$53.46	\$72.01

Special Calculation Note : Other is Health Retirement Account

Operator "A"

John Henry Rock Drill, D-6 (or equivalent) and above, Trackhoe Digger, (320 Track excavator), Cranes (greater then 25 tons and less than 45 tons).

Operator "B"

Cranes (greater than 6 tons and up to 25 tons), Backhoes, Road Tractor, Dozer up to D-5, Pressure Digger- wheeled or tracked, all Tension wire Stringing equipment.

Operator "C"

Trench, Backhoe, Riding type vibratory Compactor, Ground Rod Driver, Boom Truck (6 ton & below), Skid Steer Loaders, Material Handler.

Ratio :

(1) Journeyman Lineman to (1) Apprentice

Jurisdiction (* denotes special jurisdictional note) :

ADAMS, ASHLAND, ASHTABULA, ATHENS, AUGLAIZE, BELMONT, BROWN, BUTLER, CARROLL, CHAMPAIGN, CLARK, CLERMONT, CLINTON, COLUMBIANA, COSHOCTON, CRAWFORD, CUYAHOGA, DARKE, DELAWARE, FAIRFIELD, FAYETTE, FRANKLIN, GALLIA, GEAUGA, GREENE, GUERNSEY, HAMILTON, HARRISON, HIGHLAND, HOCKING, HOLMES, JACKSON, JEFFERSON, KNOX, LAKE, LAWRENCE, LICKING, LOGAN, LORAIN, MADISON, MAHONING, MARION, MEDINA, MEIGS, MERCER, MIAMI, MONROE, MONTGOMERY, MORGAN, MORROW, MUSKINGUM, NOBLE, PERRY, PICKAWAY, PIKE, PORTAGE, PREBLE, RICHLAND, ROSS, SCIOTO, SHELBY, STARK, SUMMIT, TRUMBULL, TUSCARAWAS, UNION, VINTON, WARREN, WASHINGTON, WAYNE

Special Jurisdictional Note : 0.30 is for Health Retirement Account.

Details :

Heli - Arc Welding will be paid \$.30 above Journeyman rate. Additional compensation of 10% over the Journeyman Lineman and Journeyman Technician for performing work on structures outside of buildings such as water towers, smoke stacks, radio and television towers, more than 75' above the ground.

Prevailing Wage Rate Skilled Crafts

Name of Union: Electrical Local 71 Voice Data Video Outside

Change # : LCR01-2017fbLoc71VDV

Craft : Voice Data Video Effective Date : 10/18/2017 Last Posted : 10/18/2017

Classification	BHR	Fringe Benefit Payments						Irrevocable Fund		Total PWR	Overtime Rate
		H&W	Pension	App Tr.	Vac.	Annuity	Other	LECET (*)	MISC (*)		
Electrical Installer Technician I	\$23.46	\$5.50	\$0.70	\$0.00	\$0.00	\$0.30	\$0.00	\$0.00	\$0.00	\$29.96	\$41.69
Installer Technician II	\$22.37	\$5.50	\$0.67	\$0.00	\$0.00	\$0.30	\$0.00	\$0.00	\$0.00	\$28.84	\$40.03
Equipment Operator I	\$22.37	\$5.50	\$0.67	\$0.00	\$0.00	\$0.30	\$0.00	\$0.00	\$0.00	\$28.84	\$40.03
Equipment Operator II	\$18.43	\$5.50	\$0.55	\$0.00	\$0.00	\$0.30	\$0.00	\$0.00	\$0.00	\$24.78	\$33.99
Installer /Repair Outside	\$22.37	\$5.50	\$0.67	\$0.00	\$0.00	\$0.30	\$0.00	\$0.00	\$0.00	\$28.84	\$40.03
Ground Driver W/CDL	\$15.83	\$5.50	\$0.47	\$0.00	\$0.00	\$0.30	\$0.00	\$0.00	\$0.00	\$22.10	\$30.01
Groundman	\$13.24	\$5.50	\$0.40	\$0.00	\$0.00	\$0.30	\$0.00	\$0.00	\$0.00	\$19.44	\$26.06
Cable Splicer	\$23.46	\$5.50	\$0.70	\$0.00	\$0.00	\$0.30	\$0.00	\$0.00	\$0.00	\$29.96	\$41.69

Special Calculation Note :

Ratio :

Jurisdiction (* denotes special jurisdictional note) :

ADAMS, ASHLAND, ASHTABULA, ATHENS, AUGLAIZE, BELMONT, BROWN, BUTLER, CARROLL, CHAMPAIGN, CLARK, CLERMONT, CLINTON, COLUMBIANA, COSHOCTON, CRAWFORD, CUYAHOGA, DARKE, DELAWARE, FAIRFIELD, FAYETTE, FRANKLIN, GALLIA, GEauga, GREENE, GUERNSEY, HAMILTON, HARRISON, HIGHLAND, HOCKING, HOLMES, JACKSON, JEFFERSON, KNOX, LAKE, LAWRENCE, LICKING, LOGAN, LORAIN, MADISON, MAHONING, MARION, MEDINA, MEIGS, MERCER, MIAMI, MONROE, MONTGOMERY, MORGAN, MORROW, MUSKINGUM, NOBLE, PERRY, PICKAWAY, PIKE, PORTAGE, PREBLE, RICHLAND, ROSS, SCIOTO, SHELBY, STARK, SUMMIT,

TRUMBULL, TUSCARAWAS, UNION, VINTON,
WARREN, WASHINGTON, WAYNE

Special Jurisdictional Note :

Details :

Cable Splicer: Inspect and test lines or cables, analyze results, and evaluate transmission characteristics. Cover conductors with insulation or seal splices with moisture-proof covering. Install, splice, test, and repair cables using tools or mechanical equipment. This will include the splicing of fiber.

Journeyman Technician I: Must know all aspects of telephone and cable work. This is to include aerial, underground, and manhole work. Must know how to climb and run bucket. Must have all the tools required to perform these tasks. Must be able to be responsible for the safety of the crew at all times. Must also have CDL license and have at least 5 years experience.

Installer/Repairman: Perform tasks of repairing, installing, and testing phone and CATV services.

Technician II: Have at least three years of telephone and CATV experience. Must have the knowledge of underground, aerial, and manhole work. Must be able to climb and operate bucket. Must have CDL. Must have all tools needed to perform these tasks.

Equipment Operator I: Able to operate a digger derrick or bucket truck. Have at least 5 years of experience and must have a valid CDL license.

Equipment Operator II: Able to operate a digger derrick or bucket truck. Have at least 3 years of experience and must have a valid CDL license.

Groundman W/CDL: Must have a valid CDL license and be able to perform tasks such as: climbing poles, pulling downguys, making up material, and getting appropriate tools for the job. Must have at least 5 year's experience.

Groundman: Perform tasks such as: climbing poles, pulling downguys, making up material, and getting appropriate tools for the job. Experience 0-5 years.

Prevailing Wage Rate Skilled Crafts

Name of Union: Electrical Local 82 Inside

Change # : LCN02-2019fbLoc82in

Craft : Electrical Effective Date : 12/18/2019 Last Posted : 12/18/2019

	BHR		Fringe Benefit Payments					Irrevocable Fund		Total PWR	Overtime Rate	
			H&W	Pension	App Tr.	Vac.	Annuity	Other	LECET (*)			MISC (*)
Classification												
Electrician	\$31.15		\$7.20	\$9.03	\$0.53	\$0.00	\$3.20	\$0.00	\$0.00	\$0.00	\$51.11	\$66.68
Apprentice	Percent											
1st period 0 - 1000 hrs	42.00	\$13.08	\$3.82	\$0.59	\$0.22	\$0.00	\$0.00	\$0.00	\$0.00	\$0.00	\$17.71	\$24.25
2nd period 1001-2000 hrs	42.00	\$13.08	\$3.82	\$0.59	\$0.22	\$0.00	\$0.00	\$0.00	\$0.00	\$0.00	\$17.71	\$24.25
3rd period 2001-3500 hrs	47.00	\$14.64	\$6.67	\$4.25	\$0.25	\$0.00	\$1.50	\$0.00	\$0.00	\$0.00	\$27.31	\$34.63
4th period 3501-5000 hrs	52.00	\$16.20	\$6.72	\$4.70	\$0.28	\$0.00	\$1.66	\$0.00	\$0.00	\$0.00	\$29.56	\$37.66
5th period 5001-6500 hrs	62.00	\$19.31	\$6.82	\$5.60	\$0.33	\$0.00	\$1.98	\$0.00	\$0.00	\$0.00	\$34.04	\$43.70
6th period 6501-8000 hrs	75.00	\$23.36	\$7.20	\$6.78	\$0.40	\$0.00	\$2.40	\$0.00	\$0.00	\$0.00	\$40.14	\$51.82

Special Calculation Note : No special calculations for this skilled craft wage rate are required at this time.

Ratio :

1 to 3 Journeymen to 3 Apprentices
4 to 6 Journeymen to 6 Apprentices
per job site

Jurisdiction (* denotes special jurisdictional note) :

CLINTON, DARKE, GREENE, MIAMI,
MONTGOMERY, PREBLE, WARREN*

Special Jurisdictional Note : The following townships in Warren County are included: Clearcreek, Franklin and Wayne.

Details :

Only correction made on 6-19-19 was the 5th year Apprentice fb.

Prevailing Wage Rate Skilled Crafts

Name of Union: Electrical Local 82 Inside Lt Commercial South West

Change # : LCNO1-2019fbLoc82in

Craft : Electrical Effective Date : 09/19/2019 Last Posted : 09/19/2019

	BHR		Fringe Benefit Payments					Irrevocable Fund		Total PWR	Overtime Rate	
			H&W	Pension	App Tr.	Vac.	Annuity	Other	LECET (*)	MISC (*)		
Classification												
Electrician	\$30.15		\$5.95	\$8.75	\$0.66	\$0.00	\$2.45	\$0.00	\$0.00	\$0.00	\$47.96	\$63.03
CE-3 12,001-14,000	\$21.89		\$5.95	\$0.66	\$0.66	\$0.00	\$0.62	\$0.00	\$0.00	\$0.10	\$29.88	\$40.82
CE-2 10,001-12,000 Hrs	\$17.20		\$5.95	\$0.52	\$0.66	\$0.00	\$0.49	\$0.00	\$0.00	\$0.10	\$24.92	\$33.52
CE-1 8,001-10,000 Hrs	\$15.64		\$5.95	\$0.47	\$0.66	\$0.00	\$0.44	\$0.00	\$0.00	\$0.10	\$23.26	\$31.08
CW-4 6,001-8,000 Hrs	\$14.07		\$5.95	\$0.42	\$0.66	\$0.00	\$0.40	\$0.00	\$0.00	\$0.10	\$21.60	\$28.64
CW-3 4,001-6,000 Hrs	\$12.51		\$5.95	\$0.38	\$0.66	\$0.00	\$0.35	\$0.00	\$0.00	\$0.10	\$19.95	\$26.21
CW-2 2,001-4,000 Hrs	\$11.73		\$5.95	\$0.35	\$0.66	\$0.00	\$0.31	\$0.00	\$0.00	\$0.10	\$19.10	\$24.96
CW-1 0-2,000 Hrs	\$10.94		\$5.95	\$0.33	\$0.66	\$0.00	\$0.31	\$0.00	\$0.00	\$0.10	\$18.29	\$23.76
Apprentice	Percent											
1st period 0 - 1000 hrs	42.00	\$12.66	\$3.42	\$0.20	\$0.22	\$0.00	\$0.00	\$0.00	\$0.00	\$0.00	\$16.50	\$22.83
2nd period 1001-2000 hrs	42.00	\$12.66	\$3.42	\$0.20	\$0.22	\$0.00	\$0.00	\$0.00	\$0.00	\$0.00	\$16.50	\$22.83
3rd period 2001-3500 hrs	47.00	\$14.17	\$6.27	\$3.69	\$0.24	\$0.00	\$1.50	\$0.00	\$0.00	\$0.00	\$25.87	\$32.96
4th period 3501-5000 hrs	52.00	\$15.68	\$6.32	\$4.08	\$0.27	\$0.00	\$1.65	\$0.00	\$0.00	\$0.00	\$28.00	\$35.84
5th period 5001-6500 hrs	62.00	\$18.69	\$6.42	\$4.87	\$0.32	\$0.00	\$1.96	\$0.00	\$0.00	\$0.00	\$32.26	\$41.61
6th period 6501-8000 hrs	75.00	\$22.61	\$6.80	\$5.89	\$0.38	\$0.00	\$2.40	\$0.00	\$0.00	\$0.00	\$38.08	\$49.39

Special Calculation Note : No special calculations for this skilled craft wage rate are required at this time.

Ratio :

1 to 3 Journeymen to 3 Apprentices
4 to 6 Journeymen to 6 Apprentices
per job site

Jurisdiction (* denotes special jurisdictional note) :

CLINTON, DARKE, GREENE, MIAMI,
MONTGOMERY, PREBLE, WARREN*

Construction Electrician and Construction Wireman Ratio

There shall be a minimum ratio of one inside Journeyman to every (4) employees of different classification per jobsite. An inside Journeyman Wireman is required on the project as the fifth (5th) worker or when apprentices are used.

Special Jurisdictional Note : The following townships in Warren County are included: Clearcreek, Franklin and Wayne.

The scope of work for the light commercial agreement shall apply to the following facilities not to exceed 200,000 square feet; office buildings, shopping centers, auto sales agencies and garages, churches, funeral homes, nursing homes, hotels, retail and wholesale facilities, small stand-alone manufacturing facilities when free standing and not part of a larger facility (not to exceed 50,000 square fee), solar projects (500 panels or less) unless otherwise covered under the agreement, lighting retrofits (when not associated with remodels involving branch re-circuiting) lighting retrofits shall be defined as the changing of lamps and ballasts in existing light fixtures and shall also include the one for one replacement of existing fixtures, warehouses, gas stations, food service centers, restaurants, entertainment facilities, hospitals, clinics, motels, residential buildings.

Details :

Prevailing Wage Rate Skilled Crafts

Name of Union: Electrical Local 82 Lightning Rod

Change # : LCR01-2019fbLoc82

Craft : Electrical Effective Date : 12/11/2019 Last Posted : 12/11/2019

	BHR	Fringe Benefit Payments						Irrevocable Fund		Total PWR	Overtime Rate
		H&W	Pension	App Tr.	Vac.	Annuity	Other	LECET (*)	MISC (*)		
Classification											
Electrical Lightning Rod Technican	\$29.79	\$7.20	\$8.99	\$0.00	\$0.00	\$3.20	\$0.00	\$0.00	\$0.00	\$49.18	\$64.07

Special Calculation Note : No Apprentice approved by OSAC.

Ratio :

Jurisdiction (* denotes special jurisdictional note) :
CLINTON, DARKE, GREENE, MIAMI,
MONTGOMERY, PREBLE, WARREN*

Special Jurisdictional Note : The following townships in Warren County are included: (Clearcreek, Franklin and Wayne)

Details :

After 09-04-2018													
1st 0-1000 hours	55.00	\$13.39	\$3.00	\$0.40	\$0.25	\$0.00	\$0.25	\$0.00	\$0.00	\$0.00	\$0.00	\$17.29	\$23.99
2nd 1001-2000 hours	55.00	\$13.39	\$3.00	\$0.40	\$0.25	\$0.00	\$0.25	\$0.00	\$0.00	\$0.00	\$0.00	\$17.29	\$23.99
3rd 2001-3000 hours	65.00	\$15.83	\$6.40	\$0.47	\$0.30	\$0.00	\$4.40	\$0.00	\$0.00	\$0.00	\$0.00	\$27.40	\$35.31
4th 3001-4000 hours	65.00	\$15.83	\$6.40	\$0.47	\$0.30	\$0.00	\$4.40	\$0.00	\$0.00	\$0.00	\$0.00	\$27.40	\$35.31
5th 4001-5000 hours	75.00	\$18.26	\$6.43	\$0.55	\$0.35	\$0.00	\$4.40	\$0.00	\$0.00	\$0.00	\$0.00	\$29.99	\$39.12
6th 5001-6000 hours	75.00	\$18.26	\$6.43	\$0.55	\$0.35	\$0.00	\$4.40	\$0.00	\$0.00	\$0.00	\$0.00	\$29.99	\$39.12
7th 6001-7000 hours	80.00	\$19.48	\$6.44	\$0.58	\$0.37	\$0.00	\$4.40	\$0.00	\$0.00	\$0.00	\$0.00	\$31.27	\$41.01
8th 7001 hours	80.00	\$19.48	\$6.44	\$0.58	\$0.37	\$0.00	\$4.40	\$0.00	\$0.00	\$0.00	\$0.00	\$31.27	\$41.01
Cable Puller	50.00	\$12.18	\$3.00	\$0.37	\$0.23	\$0.00	\$0.25	\$0.00	\$0.00	\$0.00	\$0.00	\$16.02	\$22.11

Special Calculation Note : No special calculations for this skilled craft wage rate are required at this time.

Ratio :

1 Journeymen to 2 Apprentice
(Indentured After 9-4-2018)

1 Journeymen to 1 Apprentice
(Indentured Before 9--03-2018)

Jurisdiction (* denotes special jurisdictional note) :

CLINTON, DARKE, GREENE, MIAMI,
MONTGOMERY, PREBLE, WARREN*

Special Jurisdictional Note : The following townships in Warren County are included: (Clearcreek, Franklin and Wayne)

Details :

Work covered but not limited to: installation which utilize transmission and/or transference of voice, sound, vision or digital for commercial, education, security and entertainment purposes for the following:

TV monitoring and surveillance, background-foreground music, intercom and telephone interconnect, inventory control systems, microwave transmission, multimedia, multiplex, nurse call system, radio page, school intercom, sound and low voltage master clock systems.

Fire Alarm work is excluded on all new construction sites or wherever the fire alarm system is installed in conduit.

All HVAC control work is not covered by this wage rate but by the Inside Electrical wage rate.

Prevailing Wage Rate Skilled Crafts

Name of Union: Electrical Local 648 Inside

Change # : LCN01-2019fbLoc648in

Craft : Electrical Effective Date : 09/11/2019 Last Posted : 09/11/2019

	BHR		Fringe Benefit Payments					Irrevocable Fund		Total PWR	Overtime Rate	
			H&W	Pension	App Tr.	Vac.	Annuity	Other	LECET (*)			MISC (*)
Classification												
Electrician	\$30.00		\$7.10	\$8.90	\$0.45	\$0.00	\$2.50	\$0.90	\$0.00	\$0.00	\$49.85	\$64.85
Apprentice												
	Percent											
1st period 0-1000 hrs	45.00	\$13.50	\$4.07	\$0.00	\$0.20	\$0.00	\$2.50	\$0.41	\$0.00	\$0.00	\$20.68	\$27.43
2nd period 1001-2000 hrs	45.00	\$13.50	\$4.07	\$0.00	\$0.20	\$0.00	\$2.50	\$0.41	\$0.00	\$0.00	\$20.68	\$27.43
3rd period 2001-3500 hrs	50.00	\$15.00	\$7.10	\$4.45	\$0.23	\$0.00	\$2.50	\$0.45	\$0.00	\$0.00	\$29.73	\$37.23
4th period 3501-5000 hrs	55.00	\$16.50	\$7.10	\$4.90	\$0.25	\$0.00	\$2.50	\$0.50	\$0.00	\$0.00	\$31.75	\$40.00
5th period 5001-6500 hrs	62.00	\$18.60	\$7.10	\$5.52	\$0.28	\$0.00	\$2.50	\$0.56	\$0.00	\$0.00	\$34.56	\$43.86
6th period 6501-8000 hrs	71.00	\$21.30	\$7.10	\$6.32	\$0.32	\$0.00	\$2.50	\$0.64	\$0.00	\$0.00	\$38.18	\$48.83

Special Calculation Note : Other is NEBF (Natioanl Electrical Benifit Fund.)

Ratio :

3 Journeyman to 2 Apprentices or fraction thereof:
 1-3 Journeymen to 2 Apprentice
 4-6 Journeymen to 4 Apprentice
 7-9 Journeymen to 6 Apprentice
 first person assigned to any job site shall be a journeyman

Jurisdiction (* denotes special jurisdictional note) :

BUTLER, WARREN*

Special Jurisdictional Note : In Warren County the following townships are included: (Deerfield, Hamilton, Harlan, Massie, Salem, Turtle Creek, Union, and Washington)

Details :

Electricians while splicing cable shall receive \$.50 an hour above the regular electrical rate.

All work that requires the use of gas masks or respirators, shall be paid 50% above the appropriate rate of pay. Work up to & including 40 feet shall be paid \$.50 over the journeyman rate. All work from a Boatswain Chair, Swinging Scaffold, or Barrel shall be at double the Journeyman rate. Workmen required to work 50 feet or more below the surface of the earth will be paid 50% above the Journeyman rate.

Prevailing Wage Rate Skilled Crafts

Name of Union: Electrical Local 648 Lt Commercial South West

Change # : LCN01-2019fbLoc648in

Craft : Electrical Effective Date : 12/24/2019 Last Posted : 12/24/2019

Classification	BHR		Fringe Benefit Payments					Irrevocable Fund		Total PWR	Overtime Rate	
			H&W	Pension	App Tr.	Vac.	Annuity	Other	LECET (*)			MISC (*)
Electrician	\$30.00		\$7.10	\$8.90	\$0.45	\$0.00	\$2.50	\$0.90	\$0.00	\$0.00	\$49.85	\$64.85
CE-3 12,001- 14,000 Hrs	\$22.45		\$6.15	\$0.67	\$0.67	\$0.00	\$0.67	\$0.00	\$0.00	\$0.00	\$30.61	\$41.84
CE-2 10,001- 12,000 Hrs	\$17.64		\$6.15	\$0.53	\$0.67	\$0.00	\$0.53	\$0.00	\$0.00	\$0.00	\$25.52	\$34.34
CE-1 8,001- 10,000 Hrs	\$16.04		\$6.15	\$0.48	\$0.67	\$0.00	\$0.48	\$0.00	\$0.00	\$0.00	\$23.82	\$31.84
CW-4 6,001-8,000 Hrs	\$14.43		\$6.15	\$0.43	\$0.67	\$0.00	\$0.43	\$0.00	\$0.00	\$0.00	\$22.11	\$29.33
CW-3 4,001-6,000 Hrs	\$12.83		\$6.15	\$0.38	\$0.67	\$0.00	\$0.38	\$0.00	\$0.00	\$0.00	\$20.41	\$26.83
CW-2 2,001-4,000 Hrs	\$12.03		\$6.15	\$0.36	\$0.67	\$0.00	\$0.36	\$0.00	\$0.00	\$0.00	\$19.57	\$25.58
CW-1 0-2,000 Hrs	\$11.22		\$6.15	\$0.34	\$0.67	\$0.00	\$0.34	\$0.00	\$0.00	\$0.00	\$18.72	\$24.33
Apprentice Indentured AFTER 9/1/2006	Percent											
1st period 0-1000 hrs	45.00	\$13.50	\$4.07	\$0.00	\$0.20	\$0.00	\$2.50	\$0.41	\$0.00	\$0.00	\$20.68	\$27.43
2nd period 1001- 2000 hrs	45.00	\$13.50	\$4.07	\$0.00	\$0.20	\$0.00	\$2.50	\$0.41	\$0.00	\$0.00	\$20.68	\$27.43
3rd period 2001- 3500 hrs	50.00	\$15.00	\$7.10	\$4.45	\$0.23	\$0.00	\$2.50	\$0.45	\$0.00	\$0.00	\$29.73	\$37.23
4th period 3501- 5000 hrs	55.00	\$16.50	\$7.10	\$4.90	\$0.25	\$0.00	\$2.50	\$0.50	\$0.00	\$0.00	\$31.75	\$40.00
5th period 5001- 6500 hrs	62.00	\$18.60	\$7.10	\$5.52	\$0.28	\$0.00	\$2.50	\$0.56	\$0.00	\$0.00	\$34.56	\$43.86
6th period 6501- 8000 hrs	71.00	\$21.30	\$7.10	\$6.32	\$0.32	\$0.00	\$2.50	\$0.64	\$0.00	\$0.00	\$38.18	\$48.83

Special Calculation Note : Other is for NEBF (National Electrical Benifit Fund)

Ratio :

1-3 Journeymen to 2 Apprentice
4-6 Journeymen to 4 Apprentice
7-9 Journeymen to 6 Apprentice
first person assigned to any job site shall be a journeyman

Jurisdiction (* denotes special jurisdictional note) :

BUTLER, WARREN*

Construction Electrician and Construction Wireman Ratio
There shall be a minimum ratio of one inside Journeyman to every (4) employees of different classification per jobsite. An inside Journeyman Wireman is required on the project as the fifth (5th) worker or when apprentices are used

Special Jurisdictional Note : In Warren County the following townships are included: (Deerfield, Hamilton, Harlan, Massie, Salem, Turtle Creek, Union, and Washington)

The scope of work for the light commercial agreement shall apply to the following facilities not to exceed 200,000 square feet; office buildings, shopping centers, auto sales agencies and garages, churches, funeral homes, nursing homes, hotels, retail and wholesale facilities, small stand-alone manufacturing facilities when free standing and not part of a larger facility (not to exceed 50,000 square fee), solar projects (500 panels or less) unless otherwise covered under the agreement, lighting retrofits (when not associated with remodels involving branch re-circuiting) lighting retrofits shall be defined as the changing of lamps and ballasts in existing light fixtures and shall also include the one for one replacement of existing fixtures, warehouses, gas stations, food service centers, restaurants, entertainment facilities, hospitals, clinics, motels, residential buildings.

Details :

Electricians while splicing cable shall receive \$.50 an hour above the regular electrical rate.

All work that requires the use of gas masks or respirators, shall be paid 50% above the appropriate rate of pay. Work up to & including 40 feet shall be paid \$.50 over the journeyman rate. All work from a Boatswain Chair, Swinging Scaffold, or Barrel shall be at double the Journeyman rate. Workmen required to work 50 feet or more below the surface of the earth will be paid 50% above the Journeyman rate.

Prevailing Wage Rate Skilled Crafts

Name of Union: Electrical Local 648 Voice Data Video

Change # : LCR01-2019fbLoc648VDV

Craft : Voice Data Video Effective Date : 12/24/2019 Last Posted : 12/24/2019

Classification	BHR	Fringe Benefit Payments						Irrevocable Fund		Total PWR	Overtime Rate
		H&W	Pension	App Tr.	Vac.	Annuity	Other	LECET (*)	MISC (*)		
Electrical Installer Technician A	\$24.35	\$6.50	\$0.73	\$0.46	\$0.00	\$4.40	\$0.00	\$0.00	\$0.00	\$36.44	\$48.62
Electrical Installer Technician B	\$23.13	\$6.50	\$0.69	\$0.44	\$0.00	\$4.40	\$0.00	\$0.00	\$0.00	\$35.16	\$46.72
JW Installer Technician B	\$21.92	\$6.50	\$0.66	\$0.42	\$0.00	\$4.40	\$0.00	\$0.00	\$0.00	\$33.90	\$44.86
Non BICSI Installer	\$15.83	\$3.00	\$0.47	\$0.30	\$0.00	\$2.00	\$0.00	\$0.00	\$0.00	\$21.60	\$29.51
Apprentice Indentured AFTER 09-03-2018											
1st Period 0-800 Hrs	\$13.14	\$3.00	\$0.38	\$0.25	\$0.00	\$0.25	\$0.00	\$0.00	\$0.00	\$17.02	\$23.59
2nd Period 801-1600 Hrs	\$13.14	\$3.00	\$0.38	\$0.25	\$0.00	\$0.25	\$0.00	\$0.00	\$0.00	\$17.02	\$23.59
3rd Period 1601-2400 Hrs	\$15.83	\$6.00	\$0.47	\$0.30	\$0.00	\$4.00	\$0.00	\$0.00	\$0.00	\$26.60	\$34.52
4th Period 2401-3200 Hrs	\$15.83	\$6.00	\$0.47	\$0.30	\$0.00	\$4.00	\$0.00	\$0.00	\$0.00	\$26.60	\$34.52
5th Period 3201-4000 Hrs	\$18.26	\$6.03	\$0.55	\$0.35	\$0.00	\$4.00	\$0.00	\$0.00	\$0.00	\$29.19	\$38.32
6th Period 4001-4800 Hrs	\$18.26	\$6.03	\$0.55	\$0.35	\$0.00	\$4.00	\$0.00	\$0.00	\$0.00	\$29.19	\$38.32
7th Period 4801-5600 Hrs	\$19.48	\$8.04	\$0.58	\$0.30	\$0.00	\$4.00	\$0.00	\$0.00	\$0.00	\$32.40	\$42.14
8th Period 5601-6400 Hrs	\$19.48	\$8.04	\$0.58	\$0.37	\$0.00	\$4.00	\$0.00	\$0.00	\$0.00	\$32.47	\$42.21
Cable Puller	\$12.18	\$3.00	\$0.37	\$0.23	\$0.00	\$0.25	\$0.00	\$0.00	\$0.00	\$16.03	\$22.12

Apprentice Indentured PRIOR to 09-03-2018	Percent											
1st period 0-800 hrs	50.00	\$12.18	\$6.50	\$0.37	\$0.23	\$0.00	\$0.25	\$0.00	\$0.00	\$0.00	\$19.53	\$25.61
2nd period 801-1600 hrs	50.00	\$12.18	\$6.50	\$0.37	\$0.23	\$0.00	\$0.25	\$0.00	\$0.00	\$0.00	\$19.53	\$25.61
3rd period 1601-2400 hrs	60.00	\$14.61	\$6.50	\$0.44	\$0.28	\$0.00	\$4.40	\$0.00	\$0.00	\$0.00	\$26.23	\$33.54
4th period 2401-3200 hrs	65.00	\$15.83	\$6.50	\$0.47	\$0.30	\$0.00	\$4.40	\$0.00	\$0.00	\$0.00	\$27.50	\$35.41
5th period 3201-4000 hrs	70.00	\$17.04	\$6.50	\$0.51	\$0.32	\$0.00	\$4.40	\$0.00	\$0.00	\$0.00	\$28.77	\$37.30
6th period 4001-4800 hrs	75.00	\$18.26	\$6.50	\$0.55	\$0.35	\$0.00	\$4.40	\$0.00	\$0.00	\$0.00	\$30.06	\$39.19
Cable Puller	50.00	\$12.18	\$3.00	\$0.37	\$0.23	\$0.00	\$0.25	\$0.00	\$0.00	\$0.00	\$16.02	\$22.11

Special Calculation Note :

Ratio :

1 Technician to 2 Apprentice

Jurisdiction (* denotes special jurisdictional note) :

BUTLER, WARREN*

Special Jurisdictional Note : The following townships In Warren County are included: (Deerfield, Hamilton, Harlan, Massie, Salem, Turtle Creek, Union, and Washington)

Details :

The following work is excluded from the Teledata Technician work scope:

*The installation of computer systems in industrial applications such as assembly lines, robotics, computer controller manufacturing systems.

*The installation of conduit and/or raceways shall be installed by Inside Wireman. On sites where there is no Inside Wireman employed, the

Teledata Technician may install raceway or conduit not greater than 10 ft.

*Fire Alarm work is excluded on all new construction sites or wherever the fire alarm system is installed in conduit

*All HVAC control work.

Prevailing Wage Rate Skilled Crafts

Name of Union: Elevator Local 11

Change # : LCN02-2019fbLoc11

Craft : Elevator Effective Date : 01/01/2020 Last Posted : 11/26/2019

	BHR		Fringe Benefit Payments					Irrevocable Fund		Total PWR	Overtime Rate	
			H&W	Pension	App Tr.	Vac.	Annuity	Other	LECET (*)			MISC (*)
Classification												
Elevator Mechanic	\$47.23		\$15.73	\$10.21	\$0.63	\$3.78	\$8.20	\$1.51	\$0.00	\$0.00	\$87.29	\$110.90
Probationary Apprentice	50.02	\$23.62	\$0.00	\$0.00	\$0.00	\$1.42	\$0.00	\$0.76	\$0.00	\$0.00	\$25.80	\$37.62
1st year	55.00	\$25.98	\$15.73	\$10.21	\$0.63	\$1.56	\$8.20	\$0.83	\$0.00	\$0.00	\$63.14	\$76.12
2nd year	65.00	\$30.70	\$15.73	\$10.21	\$0.63	\$1.84	\$8.20	\$0.98	\$0.00	\$0.00	\$68.29	\$83.64
3rd year	70.00	\$33.06	\$15.73	\$10.21	\$0.63	\$1.98	\$8.20	\$1.06	\$0.00	\$0.00	\$70.87	\$87.40
4th year	80.00	\$37.78	\$15.73	\$10.21	\$0.63	\$2.27	\$8.20	\$1.21	\$0.00	\$0.00	\$76.03	\$94.93
Helper	70.00	\$33.06	\$15.73	\$10.21	\$0.63	\$1.98	\$8.20	\$1.06	\$0.00	\$0.00	\$70.87	\$87.40
Assistant Mechanic	80.00	\$37.78	\$15.73	\$10.21	\$0.63	\$2.27	\$8.20	\$1.21	\$0.00	\$0.00	\$76.03	\$94.93

Special Calculation Note : Other is Holiday Pay. Vacation calculated at 6%.

Ratio :

The total number of Helpers & Apprentices employed shall not exceed the number of Mechanics on any one job, except on jobs where (2) teams or more are working, (1) extra Helper or Apprentice may be employed for the first (2) teams and an extra Helper or Apprentice for each additional (3) teams.

- 1 Journeymen to 1 Apprentice
- 2 Journeymen to 5 Apprentice
- 3 Journeymen to 6 Apprentice

Special Jurisdictional Note :

Details :

Jurisdiction (* denotes special jurisdictional note) :

ADAMS, BROWN, BUTLER, CLERMONT, CLINTON, DARKE, GREENE, HAMILTON, HIGHLAND, MIAMI, MONTGOMERY, PREBLE, SCIOTO, SHELBY, WARREN

Prevailing Wage Rate Skilled Crafts

Name of Union: Glazier Local 387

Change # : LCN03-2019fbLoc387

Craft : Glazier Effective Date : 11/06/2019 Last Posted : 11/06/2019

	BHR		Fringe Benefit Payments					Irrevocable Fund		Total PWR	Overtime Rate	
			H&W	Pension	App Tr.	Vac.	Annuity	Other	LECET (*)			MISC (*)
Classification												
Glazier	\$27.03		\$5.57	\$9.85	\$0.25	\$0.00	\$0.00	\$0.00	\$0.00	\$0.00	\$42.70	\$56.22
Apprentice	Percent											
1st 6 months	55.48	\$15.00	\$5.57	\$0.00	\$0.25	\$0.00	\$0.00	\$0.00	\$0.00	\$0.00	\$20.82	\$28.31
2nd 6 months	65.00	\$17.57	\$5.57	\$5.94	\$0.25	\$0.00	\$0.00	\$0.00	\$0.00	\$0.00	\$29.33	\$38.11
3rd 6 months	70.00	\$18.92	\$5.57	\$6.46	\$0.25	\$0.00	\$0.00	\$0.00	\$0.00	\$0.00	\$31.20	\$40.66
4th 6 months	75.00	\$20.27	\$5.57	\$6.60	\$0.25	\$0.00	\$0.00	\$0.00	\$0.00	\$0.00	\$32.69	\$42.83
5th 6 months	80.00	\$21.62	\$5.57	\$7.18	\$0.25	\$0.00	\$0.00	\$0.00	\$0.00	\$0.00	\$34.62	\$45.44
6th 6 months	85.00	\$22.98	\$5.57	\$7.32	\$0.25	\$0.00	\$0.00	\$0.00	\$0.00	\$0.00	\$36.12	\$47.60
7th 6 months	90.00	\$24.33	\$5.57	\$7.84	\$0.25	\$0.00	\$0.00	\$0.00	\$0.00	\$0.00	\$37.99	\$50.15
8th 6 months	95.00	\$25.68	\$5.57	\$8.43	\$0.25	\$0.00	\$0.00	\$0.00	\$0.00	\$0.00	\$39.93	\$52.77

Special Calculation Note : No special calculations for this skilled craft wage rate are required at this time.

Ratio :

Each employer may employ and train Apprentices in the following ratio to journeymen workers employed.
1 Journeymen to 1 Apprentice

Jurisdiction (* denotes special jurisdictional note) :

ADAMS, BROWN, BUTLER, CHAMPAIGN, CLARK, CLERMONT, CLINTON, DARKE, FAYETTE*, GREENE, HAMILTON, HIGHLAND, MIAMI, MONTGOMERY, PREBLE, SHELBY*, WARREN

Special Jurisdictional Note : Fayette County: Eastern portion of route #41 being the dividing line between locals 372 and 387. Local 387 has jurisdiction of projects built on property which borders route #41 East. Shelby County: Southern portion of routes #47 & 29.

Details :

Prevailing Wage Rate Skilled Crafts

Name of Union: Ironworker Local 44

Change # : LCNO1-2019fbLoc44

Craft : Ironworker Effective Date : 06/05/2019 Last Posted : 06/05/2019

	BHR		Fringe Benefit Payments					Irrevocable Fund		Total PWR	Overtime Rate	
			H&W	Pension	App Tr.	Vac.	Annuity	Other	LECET (*)			MISC (*)
Classification												
Ironworker Reinforcing	\$29.87		\$8.20	\$9.50	\$0.60	\$0.00	\$3.00	\$0.19	\$0.00	\$0.00	\$51.36	\$66.29
Structural	\$29.37		\$8.20	\$9.50	\$0.60	\$0.00	\$3.00	\$0.19	\$0.00	\$0.00	\$50.86	\$65.54
Ornamental	\$29.37		\$8.20	\$9.50	\$0.60	\$0.00	\$3.00	\$0.19	\$0.00	\$0.00	\$50.86	\$65.54
Machine Mover/Rigger	\$29.37		\$8.20	\$9.50	\$0.60	\$0.00	\$3.00	\$0.19	\$0.00	\$0.00	\$50.86	\$65.54
Conveyer Mechanic	\$29.37		\$8.20	\$9.50	\$0.60	\$0.00	\$3.00	\$0.19	\$0.00	\$0.00	\$50.86	\$65.54
Maintenance/Heavy Hwy	\$29.37		\$8.20	\$9.50	\$0.60	\$0.00	\$3.00	\$0.19	\$0.00	\$0.00	\$50.86	\$65.54
Welder A	\$29.62		\$8.20	\$9.50	\$0.60	\$0.00	\$3.00	\$0.19	\$0.00	\$0.00	\$51.11	\$65.92
Welder B	\$29.87		\$8.20	\$9.50	\$0.60	\$0.00	\$3.00	\$0.19	\$0.00	\$0.00	\$51.36	\$66.29
Sheeter	\$29.37		\$8.20	\$9.50	\$0.60	\$0.00	\$3.00	\$0.19	\$0.00	\$0.00	\$50.86	\$65.54
Fence Erector	\$27.90		\$8.20	\$9.50	\$0.60	\$0.00	\$3.00	\$0.19	\$0.00	\$0.00	\$49.39	\$63.34
Ironworker	\$29.37		\$8.20	\$9.50	\$0.60	\$0.00	\$3.00	\$0.19	\$0.00	\$0.00	\$50.86	\$65.54
Apprentice	Percent											
Apprentice												
1st yr A	55.00	\$16.43	\$8.20	\$9.50	\$0.60	\$0.00	\$0.75	\$0.19	\$0.00	\$0.00	\$35.67	\$43.88
1st yr B	60.00	\$17.92	\$8.20	\$9.50	\$0.60	\$0.00	\$0.75	\$0.19	\$0.00	\$0.00	\$37.16	\$46.12
1st yr C	65.00	\$19.42	\$8.20	\$9.50	\$0.60	\$0.00	\$0.75	\$0.19	\$0.00	\$0.00	\$38.66	\$48.36
2nd yr A	70.00	\$20.91	\$8.20	\$9.50	\$0.60	\$0.00	\$0.75	\$0.19	\$0.00	\$0.00	\$40.15	\$50.60
2nd yr B	75.00	\$22.40	\$8.20	\$9.50	\$0.60	\$0.00	\$0.75	\$0.19	\$0.00	\$0.00	\$41.64	\$52.84
3rd yr A	80.00	\$23.90	\$8.20	\$9.50	\$0.60	\$0.00	\$1.50	\$0.19	\$0.00	\$0.00	\$43.89	\$55.83
3rd yr B	85.00	\$25.39	\$8.20	\$9.50	\$0.60	\$0.00	\$1.50	\$0.19	\$0.00	\$0.00	\$45.38	\$58.07
4th yr A	90.00	\$26.88	\$8.20	\$9.50	\$0.60	\$0.00	\$2.25	\$0.19	\$0.00	\$0.00	\$47.62	\$61.06
4th yr B	95.00	\$28.38	\$8.20	\$9.50	\$0.60	\$0.00	\$2.25	\$0.19	\$0.00	\$0.00	\$49.12	\$63.30
4th yr C	100.00	\$29.87	\$8.20	\$9.50	\$0.60	\$0.00	\$2.25	\$0.19	\$0.00	\$0.00	\$50.61	\$65.54

Special Calculation Note : Other is Impact Fund Training

Ratio :

1 Journeymen to 1 Apprentice
2 Journeymen to 2 Apprentice
10 Journeymen to 4 Apprentices

Jurisdiction (* denotes special jurisdictional note) :

ADAMS*, BROWN, BUTLER*, CLERMONT,
CLINTON*, HAMILTON, HIGHLAND*,
WARREN*

Special Jurisdictional Note : Adams County Twps included: Bratton, Scott, Winchester, Wayne. Butler County Twps included: Oxford, St. Clair, Fairfield, Morgan, Liberty, Union, Ross, Reily, Hanover, West Chester. In Clinton County, Manchester and South West Borrow. Highland County Twps included: Dotson, Salem, Clay, White Oak, Hamer, New Market, Concord, Jackson, Washington. Warren County Twps included: Harlan, Deerfield, Hamilton.

Details :

Structural Iron Work but not limited to:field fabrication, all loading to and including the erecting,rigging,assembly,dismantling, placing, temporary and permanent securing by any means of all structural iron,steel,ornamental lead,bronze,brass,copper,aluminum,glass all ferrous and non ferrous metal and composite material, precast prestressed and post-stressed concrete structures. Bridges and bridge rails,bridge viaducts,bucks bulkheads,bumper and bumper post,canopies and unistrut canopies,corrugated ferrous and non ferrous sheets when attached to steel frames,columns,beams,bar-joists,trusses,grinders,roof decking,electrical supports,elevator cars,elevator fronts and enclosures,erection of steel towers,flag poles, gymnasium equipment,stadium and arena seating,jail cell work,jail cell beds,benches,bunks,chairs,tables,mirrors,jail cell access doors,rigging and installation of machinery and equipment(erecting,aligning,anchoring and dismantling, erection and dismantling of tower cranes,derrick monorail systems, Chicago booms,overhead cranes,gantries,material and personnel hoists,tanks,hoppers and conveyors. All pre-engineered metal buildings and their entirety including siding,roofing, gutters, downspouts and erection of all.

Ornamental Iron Work but not limited to:all work in connection with field fabrication,handling including loading/off loading,sorting,cutting,fastening,anchoring,bending,hoisting,placing,burning,welding,and tying,dismantling of all materials used in miscellaneous iron or steel, for stairs,hand railings,rolling doors, rolling gates,rolling shutters,fence,windows,curtain wall,erection and welding of all metal, sash,architectural and ornamental treatments, but not necessarily limited to all sizes and types of ornamental,steel iron,lead,bronze,brass,copper,aluminum,all ferrous and non ferrous metals and composite materials

Fence Erector Iron Worker but not limited to: All work in connection with the field fabrication and erection of chain link fence,which includes but not limited to the loading and of the fence fabric and posts also the installation of the above.

Prevailing Wage Rate Skilled Crafts

Name of Union: Ironworker Local 290

Change # : LCN01-2019fbLoc290

Craft : Ironworker Effective Date : 06/01/2019 Last Posted : 05/23/2019

	BHR		Fringe Benefit Payments					Irrevocable Fund		Total PWR	Overtime Rate	
			H&W	Pension	App Tr.	Vac.	Annuity	Other	LECET (*)			MISC (*)
Classification												
Ironworker Structural	\$29.23		\$8.20	\$9.50	\$0.65	\$0.00	\$4.00	\$0.02	\$0.00	\$0.00	\$51.60	\$66.21
Welder	\$29.23		\$8.20	\$9.50	\$0.65	\$0.00	\$4.00	\$0.02	\$0.00	\$0.00	\$51.60	\$66.21
Fence Erector	\$29.23		\$8.20	\$9.50	\$0.65	\$0.00	\$4.00	\$0.02	\$0.00	\$0.00	\$51.60	\$66.21
Reinforcing Rods	\$29.23		\$8.20	\$9.50	\$0.65	\$0.00	\$4.00	\$0.02	\$0.00	\$0.00	\$51.60	\$66.21
Machinery Mover	\$29.23		\$8.20	\$9.50	\$0.65	\$0.00	\$4.00	\$0.02	\$0.00	\$0.00	\$51.60	\$66.21
Sheeter	\$29.23		\$8.20	\$9.50	\$0.65	\$0.00	\$4.00	\$0.02	\$0.00	\$0.00	\$51.60	\$66.21
Metal Building Erector	\$29.23		\$8.20	\$9.50	\$0.65	\$0.00	\$4.00	\$0.02	\$0.00	\$0.00	\$51.60	\$66.21
Rigger & Erector	\$29.29		\$8.20	\$9.50	\$0.65	\$0.00	\$4.00	\$0.02	\$0.00	\$0.00	\$51.66	\$66.30
Apprentice	Percent											
1st year	65.15	\$19.04	\$8.20	\$9.50	\$0.65	\$0.00	\$2.50	\$0.02	\$0.00	\$0.00	\$39.91	\$49.44
2nd year	75.15	\$21.97	\$8.20	\$9.50	\$0.65	\$0.00	\$2.50	\$0.02	\$0.00	\$0.00	\$42.84	\$53.82
3rd year	85.15	\$24.89	\$8.20	\$9.50	\$0.65	\$0.00	\$2.50	\$0.02	\$0.00	\$0.00	\$45.76	\$58.20
4th year	95.15	\$27.81	\$8.20	\$9.50	\$0.65	\$0.00	\$2.50	\$0.02	\$0.00	\$0.00	\$48.68	\$62.59

Special Calculation Note : Other is for Industry Fund.

Ratio :

3 Journeymen to 1 Apprentice

Jurisdiction (* denotes special jurisdictional note) :

ALLEN*, AUGLAIZE, BUTLER*, CHAMPAIGN*, CLARK, CLINTON, DARKE, FAYETTE*, GREENE, HARDIN*, HIGHLAND*, LOGAN*, MADISON*, MERCER*, MIAMI, MONTGOMERY, PREBLE, SHELBY, VAN WERT*, WARREN*

Special Jurisdictional Note : Allen County Twps included are: Auglaize, Perry, Shawnee, Amanda, Spencer, Marion, Sugar Creek, American, Bath, Jackson. Butler County Twps included are: Milford, Wayne, Madison, Lemon. Champaign Cnty Twps included are: Union, Urbana, Jackson, Concord, Salem, Mad River, Johnson, Harrison, Adams. Fayette County Twps included are: Green, Jasper, Concord, Jefferson. Hardin County Twps included are: Round Head, Marion,

Liberty. Highland County Twps included are: Fairfield, Penn, Union, Marshall, Liberty, Paint, Brush Creek. Logan County Twps included are: Richland, Stokes, Bloomfield, Washington, Harrison, McArthur, Lake, Liberty, Pleasant, Miami. Madison County Twps included are: Stokes. Mercer County Twps included are: Dublin, Washington, Jefferson, Recovery, Gibson, Union, Liberty, Butler, Granville, Center, Hopewell, Franklin, Marion. VanWert County Twps included are: Jennings. Warren County Twps included are: Franklin, Clear Creek, Turtle Creek, Wayne, Massie, Washington, Salem, Union.

Details :

Structural Iron Work but not limited to:field fabrication, all loading to and including the erecting,rigging,assembly,dismantling, placing, temporary and permanent securing by any means of all structural iron,steel,ornamental lead,bronze,brass,copper,aluminum,glass all ferrous and non ferrous metal and composite material, precast prestressed and post-stressed concrete structures. Bridges and bridge rails,bridge viaducts,bucks bulkheads,bumper and bumper post,canopies and unistrut canopies,corrugated ferrous and non ferrous sheets when attached to steel frames,columns,beams,bar-joists,trusses,grinders,roof decking,electrical supports,elevator cars,elevator fronts and enclosures,erection of steel towers,flag poles, gymnasium equipment,stadium and arena seating,jail cell work,jail cell beds,benches,bunks,chairs,tables,mirrors,jail cell access doors,rigging and installation of machinery and equipment(erection,aligning,anchoring and dismantling, erection and dismantling of tower cranes,derrick monorail systems, Chicago booms,overhead cranes,gantries,material and personnel hoists,tanks,hoppers and conveyors. All pre-engineered metal buildings and their entirety including siding,roofing, gutters, downspouts and erection of all.

Ornamental Iron Work but not limited to:all work in connection with field fabrication,handling including loading/off loading,sorting,cutting,fastening,anchoring,bending,hoisting,placing,burning,welding,and tying,dismantling of all materials used in miscellaneous iron or steel, for stairs,hand railings,rolling doors, rolling gates,rolling shutters,fence,windows,curtain wall,erection and welding of all metal, sash,architectural and ornamental treatments, but not necessarily limited to all sizes and types of ornamental,steel iron,lead,bronze,brass,copper,aluminum,all ferrous and non ferrous metals and composite materials

Fence Erector Iron Worker but not limited to: All work in connection with the field fabrication and erection of chain link fence,which includes but not limited to the loading and of the fence fabric and posts also the installation of the above.

Prevailing Wage Rate

Skilled Crafts

Name of Union: Labor HevHwy 3

Change # : LCN01-2019fbLocalHevHwy3

Craft : Laborer Group 1 Effective Date : 05/23/2019 Last Posted : 05/23/2019

	BHR		Fringe Benefit Payments					Irrevocable Fund		Total PWR	Overtime Rate	
			H&W	Pension	App Tr.	Vac.	Annuity	Other	LECET (*)			MISC (*)
Classification												
Laborer Group 1	\$31.62		\$7.00	\$3.70	\$0.45	\$0.00	\$0.00	\$0.00	\$0.10	\$0.00	\$42.87	\$58.68
Group 2	\$31.79		\$7.00	\$3.70	\$0.45	\$0.00	\$0.00	\$0.00	\$0.10	\$0.00	\$43.04	\$58.94
Group 3	\$32.12		\$7.00	\$3.70	\$0.45	\$0.00	\$0.00	\$0.00	\$0.10	\$0.00	\$43.37	\$59.43
Group 4	\$32.57		\$7.00	\$3.70	\$0.45	\$0.00	\$0.00	\$0.00	\$0.10	\$0.00	\$43.82	\$60.11
Watch Person	\$24.35		\$7.00	\$3.70	\$0.45	\$0.00	\$0.00	\$0.00	\$0.10	\$0.00	\$35.60	\$47.78
Apprentice	Percent											
0-1000 hrs	60.00	\$18.97	\$7.00	\$3.70	\$0.45	\$0.00	\$0.00	\$0.00	\$0.10	\$0.00	\$30.22	\$39.71
1001-2000 hrs	70.00	\$22.13	\$7.00	\$3.70	\$0.45	\$0.00	\$0.00	\$0.00	\$0.10	\$0.00	\$33.38	\$44.45
2001-3000 hrs	80.00	\$25.30	\$7.00	\$3.70	\$0.45	\$0.00	\$0.00	\$0.00	\$0.10	\$0.00	\$36.55	\$49.19
3001-4000 hrs	90.00	\$28.46	\$7.00	\$3.70	\$0.45	\$0.00	\$0.00	\$0.00	\$0.10	\$0.00	\$39.71	\$53.94
More than 4000 hrs	100.00	\$31.62	\$7.00	\$3.70	\$0.45	\$0.00	\$0.00	\$0.00	\$0.10	\$0.00	\$42.87	\$58.68

Special Calculation Note : Watchmen have no Apprentices. Tunnel Laborer rate with air-pressurized add \$1.00 to the above wage rate.

Ratio :

- 1 Journeymen to 1 Apprentice
- 3 Journeymen to 1 Apprentice thereafter

Jurisdiction (* denotes special jurisdictional note) :

ADAMS, ALLEN, ASHLAND, ATHENS, AUGLAIZE, BELMONT, BROWN, BUTLER, CARROLL, CHAMPAIGN, CLARK, CLERMONT, CLINTON, COLUMBIANA, COSHOCTON, CRAWFORD, DARKE, DEFIANCE, DELAWARE, FAIRFIELD, FAYETTE, FRANKLIN, FULTON, GALLIA, GREENE, GUERNSEY, HAMILTON, HANCOCK, HARDIN, HARRISON, HENRY, HIGHLAND, HOCKING, HOLMES, JACKSON, JEFFERSON, KNOX, LAWRENCE, LICKING, LOGAN, MADISON, MARION, MEIGS, MERCER, MIAMI, MONROE, MONTGOMERY, MORGAN, MORROW, MUSKINGUM, NOBLE, PAULDING, PERRY, PICKAWAY, PIKE, PREBLE, PUTNAM, RICHLAND, ROSS, SCIOTO, SENECA, SHELBY,

TUSCARAWAS, UNION, VAN WERT, VINTON,
WARREN, WASHINGTON, WAYNE, WILLIAMS,
WYANDOT

Special Jurisdictional Note : Hod Carriers and Common Laborers - Heavy, Highway, Sewer, Waterworks, Utility, Airport, Railroad, Industrial and Building Site, Sewer Plant, Waste Water Treatment Facilities Construction

Details :

Group 1

Laborer (Construction); Plant Laborer or Yardman, Right-of-way Laborer, Landscape Laborer, Highway Lighting Worker, Signalization Worker, (Swimming) Pool Construction Laborer, Utility Man, *Bridge Man, Handyman, Joint Setter, Flagperson, Carpenter Helper, Waterproofing Laborer, Slurry Seal, Seal Coating, Surface Treatment or Road Mix Laborer, Riprap Laborer & Grouter, Asphalt Laborer, Dump Man (batch trucks), Guardrail & Fence Installer, Mesh Handler & Placer, Concrete Curing Applicator, Scaffold Erector, Sign Installer, Hazardous Waste (level D), Diver Helper, Zone Person and Traffic Control.

*Bridge Man will perform work as per the October 31, 1949, memorandum on concrete forms, by and between the United Brotherhood of Carpenters and Joiners of America and the Laborers' International Union of North America, which states in; "the moving, cleaning, oiling and carrying to the next point of erection, and the stripping of forms which are not to be re-used, and forms on all flat arch work shall be done by members of the Laborers' International Union of North America."

Group 2

Asphalt Raker, Screwman or Paver, Concrete Puddler, Kettle Man (pipeline), All Machine-Driven Tools (Gas, Electric, Air), Mason Tender, Brick Paver, Mortar Mixer, Skid Steer, Sheeting & Shoring Person, Surface Grinder Person, Screedperson, Water Blast, Hand Held Wand, Power Buggy or Power Wheelbarrow, Paint Striper, Plastic fusing Machine Operator, Rodding Machine Operator, Pug Mill Operator, Operator of All Vacuum Devices Wet or Dry, Handling of all Pumps 4 inches and under (gas, air or electric), Diver, Form Setter, Bottom Person, Welder Helper (pipeline), Concrete Saw Person, Cutting with Burning Torch, Pipe Layer, Hand Spiker (railroad), Underground Person (working in sewer and waterline, cleaning, repairing and reconditioning). Tunnel Laborer (without air), Caisson, Cofferdam (below 25 feet deep), Air Track and Wagon Drill, Sandblaster Nozzle Person, Hazardous Waste (level B), ***Lead Abatement, Hazardous Waste (level C)

***Includes the erecting of structures for the removal, including the encapsulation and containment of Lead abatement process.

Group 3

Blast and Powder Person, Muckers will be defined as shovel men working directly with the miners, Wrencher (mechanical joints & utility pipeline), Yarnier, Top Lander, Hazardous Waste (level A), Concrete Specialist, Curb Setter and Cutter, Grade Checker, Concrete Crew in Tunnels. Utility pipeline Tappers, Waterline, Caulker, Signal Person will receive the rate equal to the rate paid the Laborer classification for which the Laborer is signaling.

Group 4

Miner, Welder, Gunite Nozzle Person

A.) The Watchperson shall be responsible to patrol and maintain a safe traffic zone including but not limited to barrels, cones, signs, arrow boards, message boards etc.

The responsibility of a watchperson is to see that the equipment, job and office trailer etc. are secure.

Prevailing Wage Rate Skilled Crafts

Name of Union: Labor Local 534 Building

Change # : LCNO1-2019fbLoc534

Craft : Laborer Effective Date : 06/01/2019 Last Posted : 05/23/2019

	BHR		Fringe Benefit Payments					Irrevocable Fund		Total PWR	Overtime Rate	
			H&W	Pension	App Tr.	Vac.	Annuity	Other	LECET (*)			MISC (*)
Classification												
Laborer Group 1	\$27.59		\$7.00	\$3.70	\$0.45	\$0.00	\$0.00	\$0.00	\$0.10	\$0.00	\$38.84	\$52.64
Laborer Group 2	\$27.69		\$7.00	\$3.70	\$0.45	\$0.00	\$0.00	\$0.00	\$0.10	\$0.00	\$38.94	\$52.79
Laborer Group 3	\$27.79		\$7.00	\$3.70	\$0.45	\$0.00	\$0.00	\$0.00	\$0.10	\$0.00	\$39.04	\$52.94
Laborer Group 4	\$27.92		\$7.00	\$3.70	\$0.45	\$0.00	\$0.00	\$0.00	\$0.10	\$0.00	\$39.17	\$53.13
Laborer Group 5	\$28.17		\$7.00	\$3.70	\$0.45	\$0.00	\$0.00	\$0.00	\$0.10	\$0.00	\$39.42	\$53.51
Laborer Group 6	\$27.94		\$7.00	\$3.70	\$0.45	\$0.00	\$0.00	\$0.00	\$0.10	\$0.00	\$39.19	\$53.16
Laborer Group 7	\$27.14		\$7.00	\$3.70	\$0.45	\$0.00	\$0.00	\$0.00	\$0.10	\$0.00	\$38.39	\$51.96
Apprentice	Percent											
0-1000 hrs	60.00	\$16.55	\$7.00	\$3.70	\$0.45	\$0.00	\$0.00	\$0.00	\$0.10	\$0.00	\$27.80	\$36.08
1001-2000 hrs	70.00	\$19.31	\$7.00	\$3.70	\$0.45	\$0.00	\$0.00	\$0.00	\$0.10	\$0.00	\$30.56	\$40.22
2001-3000 hrs	80.00	\$22.07	\$7.00	\$3.70	\$0.45	\$0.00	\$0.00	\$0.00	\$0.10	\$0.00	\$33.32	\$44.36
3001-4000	90.00	\$24.83	\$7.00	\$3.70	\$0.45	\$0.00	\$0.00	\$0.00	\$0.10	\$0.00	\$36.08	\$48.50
4001	100.00	\$27.59	\$7.00	\$3.70	\$0.45	\$0.00	\$0.00	\$0.00	\$0.10	\$0.00	\$38.84	\$52.64

Special Calculation Note : No special calculations for this skilled craft wage rate are required at this time.

Ratio :

1 Journeyman to 1 Apprentice
3 Journeyman to 1 Apprentice

Jurisdiction (* denotes special jurisdictional note) :

BUTLER, WARREN

Special Jurisdictional Note :

Details :

Note:

Group 1: Building & Common Laborer; All general laborers work including all forms of landscaping, Rough Rider - all pump's 4 inch or smaller, Small Pump Portable Generators-Bobcat to Cleanup, Firewatch and Monitor, (Safety Person)

Group 2: Asphalt Raker, Tamper, Smoother, Hand Air Pump, Hand air Tamper, Chisel, Power Tamper, Operator, Switch, Assemblies, Handling & Laying Precast Concrete Floors & Deck Tool Repairman.

Group 3: Concrete Specialist; Skid Steers (with attachments to perform Laborer's duties) Jack Hammer * Concrete Busterman, Barco Tamper Man, Power Georgia Buggy Man, Power Sweeper Man, Vibrator, Concrete Saw Man, Rail Spikers, Acetylene Burner, Pipelayers, Bos'n Cradleman, Bottom Man, Chipping Hammer Grade Checker, Radio Operator, Form Cleanout & blowout Man, Red Concrete Coloring Man (Electrical Safety)

Group 4: Mason Tender, Mortar Mixers & Scaffold Builders

Group 5: Fork Lift for Mason, all work involving Refractory Materials Including Demolition of Refractory Materials.

Asbestos Removal and Hazardous Waste Removal (handling, control, removal abatement, encapsulation or disposal of asbestos & hazardous waste),

Group 6: Gunnite Man, Sand Blaster, Concrete & Grout Pump & Hose Man, Blast Trac, Miners & Muckers, Free Air, Powderman or Blaster, Mortar or Gypsum Machineman, Welder, Scuba Diver.

Group 7: Watchman & Tool Checker/Toolroom Man

Prevailing Wage Rate Skilled Crafts

Name of Union: Operating Engineers - Building Local 18 - Zone III

Change # : LCN01-2019fbLoc18zone3

Craft : Operating Engineer Effective Date : 05/01/2019 Last Posted : 05/01/2019

Classification	BHR		Fringe Benefit Payments					Irrevocable Fund		Total PWR	Overtime Rate	
			H&W	Pension	App Tr.	Vac.	Annuity	Other	LECET (*)			MISC (*)
Operator Class 1	\$37.14		\$8.26	\$6.00	\$0.85	\$0.00	\$0.00	\$0.09	\$0.00	\$0.00	\$52.34	\$70.91
Class 2	\$37.02		\$8.26	\$6.00	\$0.85	\$0.00	\$0.00	\$0.09	\$0.00	\$0.00	\$52.22	\$70.73
Class 3	\$35.98		\$8.26	\$6.00	\$0.85	\$0.00	\$0.00	\$0.09	\$0.00	\$0.00	\$51.18	\$69.17
Class 4	\$34.80		\$8.26	\$6.00	\$0.85	\$0.00	\$0.00	\$0.09	\$0.00	\$0.00	\$50.00	\$67.40
Class 5	\$29.34		\$8.26	\$6.00	\$0.85	\$0.00	\$0.00	\$0.09	\$0.00	\$0.00	\$44.54	\$59.21
Class 6	\$37.39		\$8.26	\$6.00	\$0.85	\$0.00	\$0.00	\$0.09	\$0.00	\$0.00	\$52.59	\$71.28
Class 7	\$37.64		\$8.26	\$6.00	\$0.85	\$0.00	\$0.00	\$0.09	\$0.00	\$0.00	\$52.84	\$71.66
Class 8	\$38.14		\$8.26	\$6.00	\$0.85	\$0.00	\$0.00	\$0.09	\$0.00	\$0.00	\$53.34	\$72.41
Class 9	\$38.39		\$8.26	\$6.00	\$0.85	\$0.00	\$0.00	\$0.09	\$0.00	\$0.00	\$53.59	\$72.78
Apprentice	Percent											
1st Year	50.00	\$18.57	\$8.26	\$6.00	\$0.85	\$0.00	\$0.00	\$0.09	\$0.00	\$0.00	\$33.77	\$43.06
2nd Year	60.00	\$22.28	\$8.26	\$6.00	\$0.85	\$0.00	\$0.00	\$0.09	\$0.00	\$0.00	\$37.48	\$48.63
3rd Year	70.00	\$26.00	\$8.26	\$6.00	\$0.85	\$0.00	\$0.00	\$0.09	\$0.00	\$0.00	\$41.20	\$54.20
4th Year	80.00	\$29.71	\$8.26	\$6.00	\$0.85	\$0.00	\$0.00	\$0.09	\$0.00	\$0.00	\$44.91	\$59.77
Field Mechanic Trainee												
1st Year	50.00	\$18.57	\$8.26	\$6.00	\$0.85	\$0.00	\$0.00	\$0.09	\$0.00	\$0.00	\$33.77	\$43.06
2nd Year	60.00	\$22.28	\$8.26	\$6.00	\$0.85	\$0.00	\$0.00	\$0.09	\$0.00	\$0.00	\$37.48	\$48.63
3rd Year	70.00	\$26.00	\$8.26	\$6.00	\$0.85	\$0.00	\$0.00	\$0.09	\$0.00	\$0.00	\$41.20	\$54.20
4th Year	80.00	\$29.71	\$8.26	\$6.00	\$0.85	\$0.00	\$0.00	\$0.09	\$0.00	\$0.00	\$44.91	\$59.77

Special Calculation Note : Other: Education & Safety \$0.09

Ratio :

For every (3) Operating Engineer Journeymen employed by the company there may be employed (1) Registered Apprentice or trainee Engineer through the referral when they are available. An apprentice, while employed as part of a crew per Article VIII, paragraph 77, will not be subject to the apprenticeship ratios in this collective bargaining agreement

Jurisdiction (* denotes special jurisdictional note) :

ADAMS, ALLEN, ASHLAND, ATHENS, AUGLAIZE, BELMONT, BROWN, BUTLER, CARROLL, CHAMPAIGN, CLARK, CLERMONT, CLINTON, COSHOCTON, CRAWFORD, DARKE, DEFIANCE, DELAWARE, FAIRFIELD, FAYETTE, FRANKLIN, FULTON, GALLIA, GREENE, GUERNSEY, HAMILTON, HANCOCK, HARDIN, HARRISON, HENRY, HIGHLAND, HOCKING, HOLMES, JACKSON, JEFFERSON, KNOX, LAWRENCE, LICKING, LOGAN, MADISON, MARION, MEIGS, MERCER, MIAMI, MONROE, MONTGOMERY, MORGAN, MORROW, MUSKINGUM, NOBLE, OTTAWA, PAULDING, PERRY, PICKAWAY, PIKE, PREBLE, PUTNAM, RICHLAND, ROSS, SANDUSKY, SCIOTO, SENECA, SHELBY, STARK, TUSCARAWAS,

UNION, VAN WERT, VINTON, WARREN,
WASHINGTON, WAYNE, WILLIAMS, WYANDOT

Special Jurisdictional Note :

Details :

**Apprentices will receive a 10% increase on top of the percentages listed above provided they are operating mobile equipment. Mechanic Trainees will receive 10% increase if required to have CDL

Class 1 - Barrier Moving Machine; Boiler Operators or Compressor Operators, when compressor or boiler is mounted on crane (Piggyback Operation); Boom Trucks (all types); Cableways Cherry Pickers; Combination - Concrete Mixers & Towers; All Concrete Pumps with Booms; Cranes (all types) Derricks (all types); Draglines Dredges (dipper, clam or suction) 3-man crew; Elevating Graders or Euclid Loaders; Floating Equipment; Gradalls; Helicopter Operators; hoisting building materials; Helicopter Winch Operators, Hoisting building materials; Hoes (All types); Hoists (with two or more drums in use); Hydraulic Gantry (lift system); Laser Finishing Machines; Lift Slab or Panel Jack Operators; Locomotives (all types); Maintenance Engineers (Mechanic and/or Welder); Mixers, paving (multiple drum); Mobile Concrete Pumps, with booms, Panelboards, (all types on site); Pile Drivers; Power Shovels; Prentice Loader; Rail Tamper (with automatic lifting and aligning device); Rotary Drills (all) used on caissons for foundations and sub-structure work; Side Booms; Slip Form Pavers; Straddle Carriers (Building Construction on site); Tug Boats. Horizontal Directional Drill, Rough Terrain Fork-lift with Winch/Hoist, Laser Screed, and Like equipment; Compact Cranes, track or rubber over 4,000 pound capacity, self-erecting cranes: stationary, track or truck (all configurations) bucket trench machines (over 24 " wide).

Class 2 - Asphalt Pavers; Bobcat-type and/or skid steer loader with hoe attachment greater than 7000 lbs. Bulldozers; CMI type Equipment; Endloaders; Hydro Milling Machine; Kolman-type Loaders (Dirt Loading); Lead Greasemen; Mucking Machines; Pettibone-Rail Equipment; Power Graders; Power Scoops; Power Scrapers; Push Cats; Vermeer Type Concrete Saw; All rotomills, grinders & planers of all types. Articulating/end dumps (minus \$4.00/hour from Class 2 rate)

Class 3 - A Frames; Air Compressors, Pressurizing Shafts or Tunnels; All Asphalt Rollers; Bobcat-type and/or skid steer loader with or without attachments; Boilers (15 lbs pressure and over); All concrete Pumps (without booms with 5 inch system); Fork Lifts (except masonry); Highway Drillers - all types (with integral power); Hoists (with one drum); House Elevators (except those automatic call button controlled); Man lifts; Mud Jacks; Pressure Grouting; Pump Operators (installing or operating Well Points or other types of Dewatering Systems); Pumps (4 inches and over discharge); Railroad Tie Inserter/Remover; Rotator (Lime-Soil Stabilizer); Submersible Pumps (4 inches and over discharge); Switch & Tie Tampers (without lifting and aligning device); Trench Machines (24 inches and under); Utility Operators; Material hoist/elevators.

Class 4 - Ballast Re-locator; Backfillers and Tampers; Batch Plant Operators; Bar and Joint Installing Machines; Bull Floats; Burlap and Curing Machines; Clefplanes; Compressors, on building construction; Concrete Spreader; Conveyors, used for handling building materials; Concrete Mixers, one bag capacity (side loader); Concrete Mixers, capacity more than one bag; Crushers; Deck Hands; Drum Fireman (in Asphalt Plant); Farm type tractors pulling attachments; Finishing Machines; Form Trenchers; Generators; Guniting Machines; Hydro-Seeders; Pavement Breakers (hydraulic or cable); Post Drivers; Post Hole Diggers; Pressure Pumps (over 1/2 inch discharge); Road Widening Trenchers; Rollers (except asphalt); All Concrete pumps (without Boom with 4 inch or smaller systems); Self-Propelled Power Spreaders; Concrete Spreaders; Self-Propelled Sub-graders; Shotcrete Machines; Tire Repairmen; Tractors, pulling sheepfoot rollers or graders; VAC/ALLS; Vibratory Compactors, with integral power; Welder Operators.

Class 5 - Boilers (less than 15 lbs. pressure); Inboard/outboard Motor Boat Launches; Light Plant Operators; Masonry Fork Lifts; Oilers/Helpers; Power Driven Heaters (oil fired); Power Scrubbers; Power Sweepers; Pumps (under 4 inch discharge); Signalmen, Submersible Pumps (under 4 inch discharge). Directional Drill Locator and Allen Screed Concrete Paver. Fueling and greasing (plus \$3.00), compact cranes; track or rubber under 4,000 pounds.

Class 6 - Master Mechanic

Class 7 - Boom & Jib 150 - 180 feet

Class 8 - Boom & Jib 180 - 249 feet

Class 9 - Boom & Jib 250 - or over

Prevailing Wage Rate Skilled Crafts

Name of Union: Operating Engineers - HevHwy Zone II

Change # : LCN01-2019fbLoc18hevhwyl

Craft : Operating Engineer Effective Date : 05/01/2019 Last Posted : 05/01/2019

	BHR		Fringe Benefit Payments					Irrevocable Fund		Total PWR	Overtime Rate	
			H&W	Pension	App Tr.	Vac.	Annuity	Other	LECET (*)			MISC (*)
Classification												
Operator Class 1	\$37.14	\$8.26	\$6.00	\$0.85	\$0.00	\$0.00	\$0.09	\$0.00	\$0.00	\$52.34	\$70.91	
Class 2	\$37.02	\$8.26	\$6.00	\$0.85	\$0.00	\$0.00	\$0.09	\$0.00	\$0.00	\$52.22	\$70.73	
Class 3	\$35.98	\$8.26	\$6.00	\$0.85	\$0.00	\$0.00	\$0.09	\$0.00	\$0.00	\$51.18	\$69.17	
Class 4	\$34.80	\$8.26	\$6.00	\$0.85	\$0.00	\$0.00	\$0.09	\$0.00	\$0.00	\$50.00	\$67.40	
Class 5	\$29.34	\$8.26	\$6.00	\$0.85	\$0.00	\$0.00	\$0.09	\$0.00	\$0.00	\$44.54	\$59.21	
Class 6	\$37.39	\$8.26	\$6.00	\$0.85	\$0.00	\$0.00	\$0.09	\$0.00	\$0.00	\$52.59	\$71.28	
Apprentice	Percent											
1st Year	50.00	\$18.57	\$8.26	\$6.00	\$0.85	\$0.00	\$0.00	\$0.09	\$0.00	\$33.77	\$43.06	
2nd Year	60.00	\$22.28	\$8.26	\$6.00	\$0.85	\$0.00	\$0.00	\$0.09	\$0.00	\$37.48	\$48.63	
3rd Year	70.00	\$26.00	\$8.26	\$6.00	\$0.85	\$0.00	\$0.00	\$0.09	\$0.00	\$41.20	\$54.20	
4th Year	80.00	\$29.71	\$8.26	\$6.00	\$0.85	\$0.00	\$0.00	\$0.09	\$0.00	\$44.91	\$59.77	
Field Mech Trainee Class 2												
1st year	49.85	\$18.51	\$8.26	\$6.00	\$0.85	\$0.00	\$0.00	\$0.09	\$0.00	\$33.71	\$42.97	
2nd year	59.79	\$22.21	\$8.26	\$6.00	\$0.85	\$0.00	\$0.00	\$0.09	\$0.00	\$37.41	\$48.51	
3rd year	69.77	\$25.91	\$8.26	\$6.00	\$0.85	\$0.00	\$0.00	\$0.09	\$0.00	\$41.11	\$54.07	
4th year	79.75	\$29.62	\$8.26	\$6.00	\$0.85	\$0.00	\$0.00	\$0.09	\$0.00	\$44.82	\$59.63	

Special Calculation Note : Other: Education & Safety Fund is \$0.09 per hour.

Ratio :

For every (3) Operating Engineer Journeymen employed by the company , there may be employed (1) Registered Apprentice or Trainee Engineer through the referral when they are available. An apprentice, while employed as part of a crew per Article VIII paragraph 65, will not be subject the apprenticeship ratios in this collective bargaining agreement.

Jurisdiction (* denotes special jurisdictional note) :

ADAMS, ALLEN, ASHLAND, ATHENS, AUGLAIZE, BELMONT, BROWN, BUTLER, CARROLL, CHAMPAIGN, CLARK, CLERMONT, CLINTON, COSHOCTON, CRAWFORD, DARKE, DEFIANCE, DELAWARE, FAIRFIELD, FAYETTE, FRANKLIN, FULTON, GALLIA, GREENE, GUERNSEY, HAMILTON, HANCOCK, HARDIN, HARRISON, HENRY, HIGHLAND, HOCKING, HOLMES, HURON, JACKSON, JEFFERSON, KNOX, LAWRENCE, LICKING, LOGAN, LUCAS, MADISON, MARION, MEIGS, MERCER, MIAMI, MONROE, MONTGOMERY, MORGAN, MORROW, MUSKINGUM, NOBLE, OTTAWA, PAULDING, PERRY, PICKAWAY, PIKE, PREBLE, PUTNAM, RICHLAND, ROSS, SANDUSKY, SCIOTO, SENECA,

SHELBY, STARK, TUSCARAWAS, UNION, VAN
WERT, VINTON, WARREN, WASHINGTON,
WAYNE, WILLIAMS, WOOD, WYANDOT

Special Jurisdictional Note :

Details :

**Apprentices will receive a 10% increase on top of the percentages listed above provided they are operating mobile equipment. Mechanic Trainees will receive 10% increase if they are required to have CDL.

Class 1 - Air Compressors on Steel Erection; Barrier Moving Machine; Boiler Operators, on Compressors or Generators, when mounted on a rig; Cableways, Combination Concrete mixers & Towers; Concrete Pumps; Concrete Plants (over 4 yd capacity); Cranes (all types, including Boom Trucks, Cherry Pickers); Derricks; Draglines, Dredgers (dipper, clam or suction); Elevating Graders or Euclid Loaders; Floating Equipment (all types); Gradalls, Helicopter Crew (Operator- hoist or winch); Hoes (all types); Hoisting Engines, on shaft or tunnel work; Hydraulic Gantry (lifting system); Industrial - Type Tractors; Jet Engine Dryers (D8 or D9), Diesel Tractors; Locomotives (standard gage); Maintenance Operators (class A); Mixers, paving (single or double drum); Mucking Machines; Multiple Scrapers; Piledriving Machines (all types); Power Shovels, Prentice Loader; Quad 9 (double pusher); Rail Tamper (with automatic lifting and aligning device); Refrigerating Machines (freezer operation); Side Booms; Slip Form Pavers; Tower Dericks; Tree Shredders; Truck Mounted Concrete Pumps; Tug Boats; Tunnel Machines and /or Mining Machines; Wheel Excavators. Rough Terrain Fork-lift with Winch/Hoist; Compact Cranes, track rubber over 4,000 pound capacity, self-erecting cranes; stationary, track or truck (all configurations) Bucket trench machines (over 24 inches wide).

Class 2 - Asphalt Pavers; Automatic Subgrade Machines, self-propelled (CMI-type); Bobcat-type and /or skid steer loader with hoe attachment greater than 7000 lbs.; Boring Machine Operators (more than 48 inches); Bulldozers; Endloaders; Hydro Milling Machine; Kolman-type Loaders (production type-dirt); Lead Greasemen; Maintenance Operators, Class B (Portage and Summit Counties only); Pettibone-Rail Equipment; Power Graders; Power Scrapers; Push Cats; Lighting and Traffic Signal Installation Equipment includes all groups or classifications; Trench Machines (24inch wide and under); Vermeer Type Concrete saw. Material Transfer Equipment (Shuttle buggy) Asphalt; All rotomills,grinders and planers of all types. Horizontal Directional Drill (Over 50,000 ft.lbs.thrust and over)

Class 3 - A-Frames; Air Compressors, on tunnel work (low Pressure); Asphalt Plant Engineers; Bobcat-type and/or skid steer loader with or without attachments; Power Boilers (15 lbs pressure and over); Highway Drills (all types); Rollers, asphalt; Pump Operators (installing or operating well Points); Pumps (4 inch and over discharge); Railroad Tie Inserter/Remover; Rotator (lime-soil Stabilizer), Switch & Tie Tampers (without lifting and aligning device); Locomotives (narrow gage); Mixers, concrete (more than one bag capacity); Mixers, one bag capacity (side loader); Utilities Operators, (small equipment); Welding Machines; Material hoist/elevators. Articulating/straight bed end dumps if assigned (minus \$4.00 per hour).

Class 4 -Ballast Re-locator; Backfillers, Batch Plants; Bar and Joint Installing Machines; Boring Machine Operators (48 inch or less); Bull Floats; Burlap and Curing Machines; Concrete Plants (capacity 4 yd and under); Conveyors (highway); Concrete Saws (multiple); Crushers; Deckhands; Farm type tractors, with attachments (highway), except masonry; Finishing Machines; Firemen, Floating Equipment (all types); Fork Lifts (highway); Form Trenchers; Hydro Hammers; Hydro Seeders; Pavement Breakers; Plant Mixers; Post Drivers; Post Hole Diggers (power auger); Power Brush Burners; Power Form Handling Equipment; Road Widening Trenchers; Rollers (brick, grade, macadam); Self-Propelled Power Spreaders; Self-Propelled Sub-Graders; Tractors, pulling sheepsfoot rollers or graders; Steam Firemen; Vibratory Compactors, with integral power.

Class 5 - Compressors (portable, Sewer, Heavy and Highway); Generators; Inboard-Outboard Motor Boat Launches; Masonry Fork Lifts; Oilers/Helpers; Power Driven Heaters; Power Scrubbers; Power Sweepers; Pumps (under 4 inch discharge); Signalmen; Drum Fireman (in Asphalt Plant); Oil Heaters (Asphalt Plant); Tire Repairmen; VAC/ALLS; Fueling and greasing (plus \$3.00), compact cranes: track or rubber under 4,000 pounds.

Class 6 - Master Mechanic

Prevailing Wage Rate Skilled Crafts

Name of Union: Painter Locals 123 & 238

Change # : OCR01-2019fbLoc123-238

Craft : Drywall Finisher Effective Date : 08/21/2019 Last Posted : 08/21/2019

	BHR		Fringe Benefit Payments						Irrevocable Fund		Total PWR	Overtime Rate
			H&W	Pension	App Tr.	Vac.	Annuity	Other	LECET (*)	MISC (*)		
Classification												
Painter Drywall Finisher	\$24.61		\$5.69	\$4.94	\$0.31	\$0.00	\$0.00	\$0.00	\$0.00	\$0.00	\$35.55	\$47.85
Tapers and Finishers	\$24.61		\$5.69	\$4.94	\$0.31	\$0.00	\$0.00	\$0.00	\$0.00	\$0.00	\$35.55	\$47.85
Apprentice	Percent											
1st year	55.00	\$13.54	\$5.69	\$2.30	\$0.31	\$0.00	\$0.00	\$0.00	\$0.00	\$0.00	\$21.84	\$28.60
2nd year	65.00	\$16.00	\$5.69	\$2.30	\$0.31	\$0.00	\$0.00	\$0.00	\$0.00	\$0.00	\$24.30	\$32.29
2rd year	75.00	\$18.46	\$5.69	\$2.30	\$0.31	\$0.00	\$0.00	\$0.00	\$0.00	\$0.00	\$26.76	\$35.99
4th year	80.00	\$19.69	\$5.69	\$2.30	\$0.31	\$0.00	\$0.00	\$0.00	\$0.00	\$0.00	\$27.99	\$37.83

Special Calculation Note : Apprentices shall be paid the proper % of the classification above.

Ratio :

1 Journeyman to 1 Apprentice per job

Jurisdiction (* denotes special jurisdictional note) :

BROWN, BUTLER, CLERMONT, CLINTON, HAMILTON, WARREN

Special Jurisdictional Note :

Details :

Industrial Work paid as commercial work above for each class which includes, Industrial Plants, repair garages, processing plants, storage tanks, warehouses, skeletons structures, bridges unless highest point of clearance is 60 feet or more whether new or old construction offices and office buildings in industrial sites are at industrial rates. Heavy & Highway Bridges-Guard Rails- Light Poles. A hazardous steeplejack rate shall apply on radio towers, stacks, light towers, water towers, steeples, skeleton steel, and exterior industrial conveyors over 25 feet, where such items require steeplejack methods and the rate of pay shall be a \$1.00 per hour above the industrial rate. Steeplejack rate to apply to bridges where highest point of clearance is 60 feet.

Prevailing Wage Rate Skilled Crafts

Name of Union: Painter Locals 123 & 238
Commercial & Industrial

Change # : OCR01-2019fbLoc123

Craft : Painter Effective Date : 08/21/2019 Last Posted : 08/21/2019

	BHR		Fringe Benefit Payments					Irrevocable Fund		Total PWR	Overtime Rate	
			H&W	Pension	App Tr.	Vac.	Annuity	Other	LECET (*)			MISC (*)
Classification												
Painter Brush Roll	\$24.61		\$5.69	\$4.94	\$0.31	\$0.00	\$0.00	\$0.00	\$0.00	\$0.00	\$35.55	\$47.85
Paper Hanger	\$24.61		\$5.69	\$4.94	\$0.31	\$0.00	\$0.00	\$0.00	\$0.00	\$0.00	\$35.55	\$47.85
Spray Painter	\$25.11		\$5.69	\$4.94	\$0.31	\$0.00	\$0.00	\$0.00	\$0.00	\$0.00	\$36.05	\$48.60
Sand Blaster Water Blaster	\$25.36		\$5.69	\$4.94	\$0.31	\$0.00	\$0.00	\$0.00	\$0.00	\$0.00	\$36.30	\$48.98
Elevated Tanks	\$25.61		\$5.69	\$4.94	\$0.31	\$0.00	\$0.00	\$0.00	\$0.00	\$0.00	\$36.55	\$49.35
Apprentice	Percent											
1st year	55.00	\$13.54	\$5.69	\$2.30	\$0.31	\$0.00	\$0.00	\$0.00	\$0.00	\$0.00	\$21.84	\$28.60
2nd year	65.00	\$16.00	\$5.69	\$2.30	\$0.31	\$0.00	\$0.00	\$0.00	\$0.00	\$0.00	\$24.30	\$32.29
3rd year	75.00	\$18.46	\$5.69	\$2.30	\$0.31	\$0.00	\$0.00	\$0.00	\$0.00	\$0.00	\$26.76	\$35.99
4th year	80.00	\$19.69	\$5.69	\$2.30	\$0.31	\$0.00	\$0.00	\$0.00	\$0.00	\$0.00	\$27.99	\$37.83

Special Calculation Note : Apprentices shall be paid the proper % of the classification above.

Ratio :

(1) Journeymen to (1) Apprentice per jobsite

Jurisdiction (* denotes special jurisdictional note) :

BROWN, BUTLER, CLERMONT, CLINTON,
HAMILTON, WARREN

Special Jurisdictional Note :

Details :

Industrial Work paid as commercial work above for each class which includes, Industrial Plants, repair garages, processing plants, storage tanks, warehouses, skeletons structures, bridges unless highest point of clearance is 60 feet or more whether new or old construction offices and office buildings in industrial sites are at industrial rates. Heavy & Highway Bridges-Guard Rails- Light Poles. A hazardous steeplejack rate shall apply on radio towers, stacks, light towers, water towers, steeples, skeleton steel, and exterior industrial conveyors over 25 feet, where such items require steeplejack methods and the rate of pay shall be a \$1.00 per hour above the industrial rate. Steeplejack rate to apply to bridges where highest point of clearance is 60 feet.

Prevailing Wage Rate Skilled Crafts

Name of Union: Painter Local 123 & 238 Hvy Hwy

Change # : OCR01-2019fbLoc123

Craft : Painter Effective Date : 08/21/2019 Last Posted : 08/21/2019

	BHR		Fringe Benefit Payments					Irrevocable Fund		Total PWR	Overtime Rate	
			H&W	Pension	App Tr.	Vac.	Annuity	Other	LECET (*)			MISC (*)
Classification												
Painter Bridge Class 1	\$30.00		\$5.69	\$4.94	\$0.31	\$0.00	\$0.00	\$0.00	\$0.00	\$0.00	\$40.94	\$55.94
Bridge Painter, Rigger, Containment Builder, Spot Blaster Class 2	\$25.00		\$5.69	\$4.94	\$0.31	\$0.00	\$0.00	\$0.00	\$0.00	\$0.00	\$35.94	\$48.44
Equipment Operator/Field Mechanic, Grit Reclamation, Paint Mixer, Traffic Control, Boat Person Class 3	\$25.00		\$5.69	\$4.94	\$0.31	\$0.00	\$0.00	\$0.00	\$0.00	\$0.00	\$35.94	\$48.44
Concrete Sealing, Concrete Blasting/Power Washing, Etc. Class 4	\$25.00		\$5.69	\$4.94	\$0.31	\$0.00	\$0.00	\$0.00	\$0.00	\$0.00	\$35.94	\$48.44
Quality Control/Quality Assurance, Traffic Safety, Competent Person Class 5	\$24.00		\$5.69	\$4.94	\$0.31	\$0.00	\$0.00	\$0.00	\$0.00	\$0.00	\$34.94	\$46.94
Apprentice	Percent											
1st year	55.00	\$16.50	\$5.69	\$2.30	\$0.31	\$0.00	\$0.00	\$0.00	\$0.00	\$0.00	\$24.80	\$33.05
2nd year	65.00	\$19.50	\$5.69	\$2.30	\$0.31	\$0.00	\$0.00	\$0.00	\$0.00	\$0.00	\$27.80	\$37.55
3rd year	75.00	\$22.50	\$5.69	\$2.30	\$0.31	\$0.00	\$0.00	\$0.00	\$0.00	\$0.00	\$30.80	\$42.05
4th year	80.00	\$24.00	\$5.69	\$2.30	\$0.31	\$0.00	\$0.00	\$0.00	\$0.00	\$0.00	\$32.30	\$44.30

Special Calculation Note : Apprentices shall be paid proper % of the classification above..

Ratio :

1 Journeyman to 1 Apprentice per job

Jurisdiction (* denotes special jurisdictional note) :

BROWN, BUTLER, CLERMONT, CLINTON,
HAMILTON, WARREN

Special Jurisdictional Note :

Details :

Industrial Work paid as commercial work above for each class which includes, Industrial Plants, repair garages, processing plants, storage tanks, warehouses, skeletons structures, bridges unless highest point of clearance is 60 feet or more whether new or old construction offices and office buildings in industrial sites are at industrial rates. Heavy & Highway Bridges-Guard Rails- Light Poles. A hazardous steeplejack rate shall apply on radio towers, stacks, light towers, water towers, steeples, skeleton steel, and exterior industrial conveyors over 25 feet, where such items require steeplejack methods and the rate of pay shall be a \$1.00 per hour above the industrial rate. Steeplejack rate to apply to bridges where highest point of clearance is 60 feet.

Class 1 – Abrasive blasting of any kind.

Class 2 – Bridge painting, coating application of any kind. All steel surface preparation other than abrasive blasting. All necessary rigging and containment building. All remedial/ spot blasting.

Class 3 – Tend to all equipment including but not limited to abrasive blasting, power washing, spray painting, forklifts, hoists, trucks, etc. Load and unload trucks, handle materials, man safety boats, handle traffic control, clean up/ vacuum abrasive blast materials and related tasks.

Class 4 – All aspects of concrete coating/ sealing including but not limited to preparation, containment, etc.

Class 5 – Verify and record that all work is completed according to job specifications. Assure that all health and safety standards are adhered to. Assure all traffic is safely handled.

Prevailing Wage Rate Skilled Crafts

Name of Union: Painter Local 639

Change # : LCNO1-2015fbLoc639

Craft : Painter Effective Date : 06/10/2015 Last Posted : 06/10/2015

	BHR	Fringe Benefit Payments						Irrevocable Fund		Total PWR	Overtime Rate
		H&W	Pension	App Tr.	Vac.	Annuity	Other	LECET (*)	MISC (*)		
Classification											
Painter Metal Finisher/Helpers											
Top Helper Class A	\$19.09	\$3.65	\$0.00	\$0.00	\$0.66	\$0.00	\$0.00	\$0.00	\$0.00	\$23.40	\$32.94
Top Helper Class B	\$19.09	\$3.65	\$0.65	\$0.00	\$1.03	\$0.00	\$0.37	\$0.00	\$0.00	\$24.79	\$34.33
Top Helper Class C	\$19.09	\$3.65	\$1.00	\$0.00	\$1.76	\$0.00	\$0.37	\$0.00	\$0.00	\$25.87	\$35.41
Helper Class A	\$14.69	\$3.65	\$0.00	\$0.00	\$0.51	\$0.00	\$0.00	\$0.00	\$0.00	\$18.85	\$26.19
Helper Class B	\$14.69	\$3.65	\$0.65	\$0.00	\$0.79	\$0.00	\$0.28	\$0.00	\$0.00	\$20.06	\$27.40
Helper Class C	\$14.69	\$3.65	\$1.00	\$0.00	\$1.64	\$0.00	\$0.28	\$0.00	\$0.00	\$21.26	\$28.60
New Hire 90 Days	\$11.00	\$3.65	\$0.00	\$0.00	\$0.00	\$0.00	\$0.00	\$0.00	\$0.00	\$14.65	\$20.15

Special Calculation Note : Other is Sick and Personal Time

Ratio :

Jurisdiction (* denotes special jurisdictional note) :

ADAMS, ALLEN, ASHLAND, ASHTABULA, ATHENS, AUGLAIZE, BELMONT, BROWN, BUTLER, CARROLL, CHAMPAIGN, CLARK, CLERMONT, CLINTON, COLUMBIANA, COSHOCTON, CRAWFORD, CUYAHOGA, DARKE, DEFIANCE, DELAWARE, ERIE, FAIRFIELD, FAYETTE, FRANKLIN, FULTON, GALLIA, GEAUGA, GREENE, GUERNSEY, HAMILTON, HANCOCK, HARDIN, HARRISON, HENRY, HIGHLAND, HOCKING, HOLMES, HURON, JACKSON, JEFFERSON, KNOX, LAKE, LAWRENCE, LICKING, LOGAN, LORAIN, LUCAS, MADISON, MAHONING, MARION, MEDINA, MEIGS, MERCER, MIAMI, MONROE, MONTGOMERY, MORGAN, MORROW, MUSKINGUM, NOBLE, OTTAWA, PAULDING, PERRY, PICKAWAY, PIKE, PORTAGE, PREBLE, PUTNAM, RICHLAND, ROSS, SANDUSKY,

SCIOTO, SENECA, SHELBY, STARK, SUMMIT,
TRUMBULL, TUSCARAWAS, UNION, VAN
WERT, VINTON, WARREN, WASHINGTON,
WAYNE, WILLIAMS, WOOD, WYANDOT

Special Jurisdictional Note :

Details :

Top Helper: Shall perform the responsibilities of a Helper and be responsible for the setup, break down, safety and quality of the company's product.

Helper : Shall be responsible for performing tasks in refinishing, compliance with safety procedures, setting up and breaking down job sites, scaffolding and swing stages and preparing surfaces for refinishing including but not limited to, masking and stripping and cleaning, oxidizing, polishing and scratch removal on various surfaces

Class A Workers: Less than 1 Year of Service.

Class B Workers: More than 1 and less than 8 Years of Service.

Class C Workers: More than 8 Years of Service.

Metal Polisher Scope of Work: Polishing, buffing, stripping, coloring, lacquering, spraying, cleaning and maintenance of ornamental and architectural metals, iron, bronze, nickel, aluminum and stainless steel and in mental specialty work, various stone finishes, stone specialty work and any other work pertaining to the finishing of metal, stones, woods, and any window washing/cleaning done in conjunction with this work, using chemicals, solvents, coatings and hand applied lacquer thinner, removing scratches from mirror finished metals, burnishing of bronze, statuary finishes on exterior and interior surfaces and the use of all tools required to perform such work, including but not limited to polishes, spray equipment and scaffolding.

Swing State Rate: All work on scaffold 4 sections or higher, including any boom lifts and swing stage scaffolds including the rigging and derigging of hanging/suspended swing stage systems and rappelling/bolson chair work, ADD \$1.50 per hour.

Prevailing Wage Rate Skilled Crafts

Name of Union: Painter Local 639 Zone 2 Sign

Change # : LCN01-2016fbLoc639

Craft : Painter Effective Date : 08/03/2016 Last Posted : 08/03/2016

	BHR	Fringe Benefit Payments						Irrevocable Fund		Total PWR	Overtime Rate
		H&W	Pension	App Tr.	Vac.	Annuity	Other	LECET (*)	MISC (*)		
Classification											
Painter Sign Journeyman Tech/Team Leader Class A	\$21.25	\$1.33	\$0.14	\$0.00	\$0.00	\$0.00	\$0.57	\$0.00	\$0.00	\$23.29	\$33.92
Painter Sign Journeyman Tech/Team Leader Class B	\$21.25	\$1.33	\$0.14	\$0.00	\$0.41	\$0.00	\$0.57	\$0.00	\$0.00	\$23.70	\$34.32
Painter Sign Journeyman Tech/Team Leader Class C	\$21.25	\$1.33	\$0.14	\$0.00	\$0.82	\$0.00	\$0.57	\$0.00	\$0.00	\$24.11	\$34.74
Painter Sign Journeyman Tech/Team Leader Class D	\$21.25	\$1.33	\$0.14	\$0.00	\$1.23	\$0.00	\$0.57	\$0.00	\$0.00	\$24.52	\$35.14
Sign Journeyman Class A	\$20.98	\$1.33	\$0.14	\$0.00	\$0.00	\$0.00	\$0.56	\$0.00	\$0.00	\$23.01	\$33.50
Sign Journeyman Class B	\$20.98	\$1.33	\$0.14	\$0.00	\$0.40	\$0.00	\$0.56	\$0.00	\$0.00	\$23.41	\$33.90
Sign Journeyman Class C	\$20.98	\$1.33	\$0.14	\$0.00	\$0.81	\$0.00	\$0.56	\$0.00	\$0.00	\$23.82	\$34.31
Sign Journeyman Class D	\$20.98	\$1.33	\$0.14	\$0.00	\$1.21	\$0.00	\$0.56	\$0.00	\$0.00	\$24.22	\$34.71
Tech Sign Fabrication/Erector Class A	\$15.90	\$1.33	\$0.14	\$0.00	\$0.00	\$0.00	\$0.43	\$0.00	\$0.00	\$17.80	\$25.75
Tech Sign Fabrication/Erector Class B	\$15.90	\$1.33	\$0.14	\$0.00	\$0.31	\$0.00	\$0.43	\$0.00	\$0.00	\$18.11	\$26.06
Tech Sign Fabrication/Erector Class C	\$15.90	\$1.33	\$0.14	\$0.00	\$0.61	\$0.00	\$0.43	\$0.00	\$0.00	\$18.41	\$26.36
Tech Sign Fabrication/Erector Class D	\$15.90	\$1.33	\$0.14	\$0.00	\$0.92	\$0.00	\$0.43	\$0.00	\$0.00	\$18.72	\$26.67

Special Calculation Note : Other is for paid holidays.

Ratio :

Jurisdiction (* denotes special jurisdictional note) :
ADAMS, ALLEN, AUGLAIZE, BROWN, BUTLER,
CARROLL, CHAMPAIGN, CLARK, CLERMONT, CLINTON,
COLUMBIANA, COSHOCTON, CRAWFORD, DARKE,
DEFIANCE, DELAWARE, ERIE, FAIRFIELD, FAYETTE,
FRANKLIN, FULTON, GREENE, HAMILTON, HANCOCK,
HARDIN, HENRY, HIGHLAND, HOLMES, HURON,
JACKSON, KNOX, LICKING, LOGAN, LORAIN, LUCAS,
MADISON, MAHONING, MARION, MERCER, MIAMI,
MONTGOMERY, MORROW, MUSKINGUM, OTTAWA,
PAULDING, PERRY, PICKAWAY, PIKE, PREBLE,
PUTNAM, ROSS, SANDUSKY, SCIOTO, SENECA,
SHELBY, STARK, TRUMBULL, TUSCARAWAS, UNION,
VAN WERT, WARREN, WAYNE, WILLIAMS, WOOD,
WYANDOT

Special Jurisdictional Note :

Details :

Class A: less than 1 year.

Class B: 1-3 years.

Class C: 3-10 years.

Class D: More than 10 years.

Prevailing Wage Rate Skilled Crafts

Name of Union: Plasterer Local 132 (Cincinnati)

Change # : LCN01-2016fbLoc132

Craft : Plasterer Effective Date : 06/24/2016 Last Posted : 06/24/2016

	BHR		Fringe Benefit Payments					Irrevocable Fund		Total PWR	Overtime Rate	
			H&W	Pension	App Tr.	Vac.	Annuity	Other	LECET (*)			MISC (*)
Classification												
Plasterer	\$23.61		\$5.59	\$6.15	\$0.50	\$0.00	\$0.60	\$0.00	\$0.00	\$0.00	\$36.45	\$48.25
Apprentice	Percent											
1st 900 hours	55.00	\$12.99	\$5.59	\$0.00	\$0.50	\$0.00	\$0.60	\$0.00	\$0.00	\$0.00	\$19.68	\$26.17
2nd 900 hours	60.00	\$14.17	\$5.59	\$0.00	\$0.50	\$0.00	\$0.60	\$0.00	\$0.00	\$0.00	\$20.86	\$27.94
3rd 900 hours	65.00	\$15.35	\$5.59	\$6.15	\$0.50	\$0.00	\$0.60	\$0.00	\$0.00	\$0.00	\$28.19	\$35.86
4th 900 hours	70.00	\$16.53	\$5.59	\$6.15	\$0.50	\$0.00	\$0.60	\$0.00	\$0.00	\$0.00	\$29.37	\$37.63
5th 900 hours	80.00	\$18.89	\$5.59	\$6.15	\$0.50	\$0.00	\$0.60	\$0.00	\$0.00	\$0.00	\$31.73	\$41.17
6th 900 hours	85.00	\$20.07	\$5.59	\$6.15	\$0.50	\$0.00	\$0.60	\$0.00	\$0.00	\$0.00	\$32.91	\$42.94
7th 900 hours	90.00	\$21.25	\$5.59	\$6.15	\$0.50	\$0.00	\$0.60	\$0.00	\$0.00	\$0.00	\$34.09	\$44.71
8th 900 hours	95.00	\$22.43	\$5.59	\$6.15	\$0.50	\$0.00	\$0.60	\$0.00	\$0.00	\$0.00	\$35.27	\$46.48

Special Calculation Note : No special calculations for this skilled craft wage rate are required at this time.

Ratio :

- 1 Journeyman to 1 Apprentice
- 4 Journeyman to 2 Apprentice
- 7 Journeyman to 3 Apprentice

Jurisdiction (* denotes special jurisdictional note) :

BROWN, BUTLER, CLERMONT, HAMILTON,
HIGHLAND, WARREN

Special Jurisdictional Note :

Details :

Apprentice and Shop Hand Pension are \$1.00 less than Journeyman.

Prevailing Wage Rate Skilled Crafts

Name of Union: Plumber Pipefitter Local 392

Change # : LCN01-2019-fbLoc392

Craft : Plumber/Pipefitter Effective Date : 06/05/2019 Last Posted : 06/05/2019

	BHR		Fringe Benefit Payments					Irrevocable Fund		Total PWR	Overtime Rate	
			H&W	Pension	App Tr.	Vac.	Annuity	Other	LECET (*)			MISC (*)
Classification												
Plumber Pipefitter	\$32.81		\$7.40	\$12.39	\$0.50	\$0.00	\$0.00	\$0.98	\$0.00	\$0.00	\$54.08	\$70.48
Plumber Helper	\$21.33		\$7.30	\$6.59	\$0.50	\$0.00	\$0.00	\$0.00	\$0.00	\$0.00	\$35.72	\$46.38
Apprentice	Percent											
1st yr	46.50	\$15.26	\$7.20	\$0.40	\$0.50	\$0.00	\$0.00	\$0.48	\$0.00	\$0.00	\$23.84	\$31.46
2nd yr	51.53	\$16.91	\$7.20	\$0.40	\$0.50	\$0.00	\$0.00	\$0.48	\$0.00	\$0.00	\$25.49	\$33.94
3rd yr	56.53	\$18.55	\$7.20	\$6.59	\$0.50	\$0.00	\$0.00	\$0.48	\$0.00	\$0.00	\$33.32	\$42.59
4th yr	61.53	\$20.19	\$7.20	\$6.59	\$0.50	\$0.00	\$0.00	\$0.48	\$0.00	\$0.00	\$34.96	\$45.05
5th yr	76.53	\$25.11	\$7.20	\$12.39	\$0.50	\$0.00	\$0.00	\$0.48	\$0.00	\$0.00	\$45.68	\$58.23

Special Calculation Note : OTHER IS: SUPPLEMENTAL UNEMPLOYMENT BENEFITS.

Ratio :

- 1 Journeymen to 1 Apprentice
- 2 Journeymen to 4 Apprentices
- 3 Journeymen to 6 Apprentices

Jurisdiction (* denotes special jurisdictional note) :

BROWN, BUTLER, CLERMONT, HAMILTON, WARREN

When more than twenty (20) Journeymen are employed additional apprentices may be acquired at a ratio of one (1) apprentice to four (4) journeymen.

Special Jurisdictional Note :

Details :

Helpers shall be permitted to work on ONLY , Exterior Sewers, Concrete, Vitrified Clay or PVC Pipe and Digging and Backfilling for Piping Work. The ratio shall not exceed 2 helpers to 1 Journeymen when performing the scope of work listed above

Prevailing Wage Rate Skilled Crafts

Name of Union: Roofer Local 42

Change # : LCNO2-2019fbLoc42

Craft : Roofer Effective Date : 09/19/2019 Last Posted : 09/19/2019

	BHR		Fringe Benefit Payments					Irrevocable Fund		Total PWR	Overtime Rate	
			H&W	Pension	App Tr.	Vac.	Annuity	Other	LECET (*)			MISC (*)
Classification												
Roofer	\$28.25		\$7.87	\$7.55	\$0.32	\$0.00	\$0.50	\$0.06	\$0.00	\$0.00	\$44.55	\$58.67
Tradesmen	\$22.60		\$7.87	\$6.04	\$0.00	\$0.00	\$0.50	\$0.03	\$0.00	\$0.00	\$37.04	\$48.34
Apprentice	Percent											
1st period	60.00	\$16.95	\$7.87	\$4.53	\$0.03	\$0.00	\$0.50	\$0.00	\$0.00	\$0.00	\$29.88	\$38.35
2nd period	70.00	\$19.77	\$7.87	\$5.28	\$0.03	\$0.00	\$0.50	\$0.00	\$0.00	\$0.00	\$33.46	\$43.34
3rd period	80.00	\$22.60	\$7.87	\$6.04	\$0.03	\$0.00	\$0.50	\$0.00	\$0.00	\$0.00	\$37.04	\$48.34

Special Calculation Note : Other is Education and Safety.

Journeymen shall receive \$1.00 per hour above journeyman rate for work with pitch material.

Ratio :

Employer may employ 1 apprentice for every 2 journeymen in his employment.

Jurisdiction (* denotes special jurisdictional note) :

ADAMS, BROWN, BUTLER, CLERMONT, HAMILTON, HIGHLAND, WARREN

Special Jurisdictional Note :

Details :

Any Tradesman Worker completing 2,000 hours in (2) years may move to Journeyman status by utilizing the Training Yard to improve their skills. Tradesman Workers will be tested at these yards to determine their competency for Journeyman status. Tradesman Workers must schedule and successfully complete the industry test battery in order to gain journeyman status.

Prevailing Wage Rate Skilled Crafts

Name of Union: Sheet Metal Local 24 (Dayton)

Change # : LCR02-2019fbLoc24(Day)

Craft : Sheet Metal Worker Effective Date : 06/19/2019 Last Posted : 06/19/2019

	BHR		Fringe Benefit Payments					Irrevocable Fund		Total PWR	Overtime Rate	
			H&W	Pension	App Tr.	Vac.	Annuity	Other	LECET (*)	MISC (*)		
Classification												
Sheet Metal Worker	\$27.72		\$8.52	\$14.46	\$0.85	\$0.00	\$0.00	\$0.00	\$0.00	\$0.00	\$51.55	\$65.41
Apprentice	Percent											
Apprentice												
5th Year B	80.00	\$22.18	\$8.26	\$11.56	\$0.85	\$0.00	\$0.00	\$0.00	\$0.00	\$0.00	\$42.85	\$53.93
5th Year A	75.00	\$20.79	\$8.20	\$10.85	\$0.85	\$0.00	\$0.00	\$0.00	\$0.00	\$0.00	\$40.69	\$51.09
4th Year B	70.00	\$19.40	\$8.13	\$10.13	\$0.85	\$0.00	\$0.00	\$0.00	\$0.00	\$0.00	\$38.51	\$48.22
4th Year A	65.00	\$18.02	\$8.07	\$9.40	\$0.85	\$0.00	\$0.00	\$0.00	\$0.00	\$0.00	\$36.34	\$45.35
3rd year B	60.00	\$16.63	\$8.01	\$8.68	\$0.85	\$0.00	\$0.00	\$0.00	\$0.00	\$0.00	\$34.17	\$42.49
3rd Year A	55.00	\$15.25	\$7.94	\$7.95	\$0.85	\$0.00	\$0.00	\$0.00	\$0.00	\$0.00	\$31.99	\$39.61
2 Year B	53.78	\$14.91	\$7.90	\$7.02	\$0.85	\$0.00	\$0.00	\$0.00	\$0.00	\$0.00	\$30.68	\$38.13
2 Year A	52.69	\$14.61	\$7.88	\$6.49	\$0.85	\$0.00	\$0.00	\$0.00	\$0.00	\$0.00	\$29.83	\$37.13
Probationary 1 Year	51.13	\$14.17	\$7.85	\$5.87	\$0.85	\$0.00	\$0.00	\$0.00	\$0.00	\$0.00	\$28.74	\$35.83

Special Calculation Note : No special calculations for this skilled craft wage rate are required at this time.

Ratio :

1 Journeyman to 1 Apprentice then,
1 Apprentice for every 2 Journeymen thereafter

Jurisdiction (* denotes special jurisdictional note) :

ALLEN, AUGLAIZE, BUTLER, CHAMPAIGN,
CLARK, CLINTON, DARKE, GREENE, HARDIN,
LOGAN, MERCER, MIAMI, MONTGOMERY,
PREBLE, SHELBY, VAN WERT, WARREN,
WYANDOT

Special Jurisdictional Note :

Details :

Prevailing Wage Rate Skilled Crafts

Name of Union: Sprinkler Fitter Local 669

Change # : LCN01-2020fbLoc669

Craft : Sprinkler Fitter Effective Date : 04/08/2020 Last Posted : 04/08/2020

	BHR		Fringe Benefit Payments						Irrevocable Fund		Total PWR	Overtime Rate
			H&W	Pension	App Tr.	Vac.	Annuity	Other	LECET (*)	MISC (*)		
Classification												
Sprinkler Fitter	\$40.40		\$10.23	\$6.80	\$0.52	\$0.00	\$5.12	\$0.10	\$0.00	\$0.00	\$63.17	\$83.37
Apprentice Indentured after April 1, 2013	Percent											
CLASS 1	45.00	\$18.18	\$7.75	\$0.00	\$0.52	\$0.00	\$0.00	\$0.10	\$0.00	\$0.00	\$26.55	\$35.64
CLASS 2	50.00	\$20.20	\$7.75	\$0.00	\$0.52	\$0.00	\$0.00	\$0.10	\$0.00	\$0.00	\$28.57	\$38.67
CLASS 3	54.38	\$21.97	\$10.23	\$6.80	\$0.52	\$0.00	\$1.15	\$0.10	\$0.00	\$0.00	\$40.77	\$51.75
CLASS 4	59.38	\$23.99	\$10.23	\$6.80	\$0.52	\$0.00	\$1.15	\$0.10	\$0.00	\$0.00	\$42.79	\$54.78
CLASS 5	64.38	\$26.01	\$10.23	\$6.80	\$0.52	\$0.00	\$1.40	\$0.10	\$0.00	\$0.00	\$45.06	\$58.06
CLASS 6	69.38	\$28.03	\$10.23	\$6.80	\$0.52	\$0.00	\$1.40	\$0.10	\$0.00	\$0.00	\$47.08	\$61.09
CLASS 7	74.38	\$30.05	\$10.23	\$6.80	\$0.52	\$0.00	\$1.40	\$0.10	\$0.00	\$0.00	\$49.10	\$64.12
CLASS 8	79.38	\$32.07	\$10.23	\$6.80	\$0.52	\$0.00	\$1.40	\$0.10	\$0.00	\$0.00	\$51.12	\$67.15
CLASS 9	84.38	\$34.09	\$10.23	\$6.80	\$0.52	\$0.00	\$1.40	\$0.10	\$0.00	\$0.00	\$53.14	\$70.18
CLASS 10	89.38	\$36.11	\$10.23	\$6.80	\$0.52	\$0.00	\$1.40	\$0.10	\$0.00	\$0.00	\$55.16	\$73.21

Special Calculation Note : \$0.10 for Other is National Fire Sprinkler Association

Ratio :

1 Journeyman to 1 Apprentice

Jurisdiction (* denotes special jurisdictional note) :

ADAMS, ALLEN, ASHLAND, ASHTABULA, ATHENS, AUGLAIZE, BELMONT, BROWN, BUTLER, CARROLL, CHAMPAIGN, CLARK, CLERMONT, CLINTON, COLUMBIANA, COSHOCTON, CRAWFORD, DARKE, DEFIANCE, DELAWARE, ERIE, FAIRFIELD, FAYETTE, FRANKLIN, FULTON, GALLIA, GREENE, GUERNSEY, HAMILTON, HANCOCK, HARDIN, HARRISON, HENRY, HIGHLAND, HOCKING, HOLMES, HURON, JACKSON, JEFFERSON, KNOX, LAWRENCE, LICKING, LOGAN, LUCAS, MADISON, MAHONING, MARION, MEDINA, MEIGS, MERCER, MIAMI, MONROE, MONTGOMERY, MORGAN, MORROW,

MUSKINGUM, NOBLE, OTTAWA, PAULDING,
PERRY, PICKAWAY, PIKE, PORTAGE, PREBLE,
PUTNAM, RICHLAND, ROSS, SANDUSKY,
SCIOTO, SENECA, SHELBY, STARK, SUMMIT,
TRUMBULL, TUSCARAWAS, UNION, VAN WERT,
VINTON, WARREN, WASHINGTON, WAYNE,
WILLIAMS, WOOD, WYANDOT

Special Jurisdictional Note :

Details :

Sprinkler Fitter work shall consist of the installation, dismantling, maintenance, repairs, adjustments, and corrections of all fire protection and fire control systems including the unloading, handling by hand, power equipment and installation of all piping or tubing, appurtenances and equipment pertaining thereto, including both overhead and underground water mains, fire hydrants and hydrant mains, standpipes and hose connections to sprinkler systems used in connection with sprinkler and alarm systems. Also all tanks and pumps connected thereto, also included shall be CO-2 and Cardox Systems, Dry Chemical Systems, Foam Systems and all other fire protection systems.

Prevailing Wage Rate

Skilled Crafts

Name of Union: Truck Driver Bldg & HevHwy Class 1
 Locals 20,40,92,92b,100,175,284,438,377,637,908,957

Change # : OCRO1-2019fbBldgHevHwy

Craft : Truck Driver Effective Date : 09/11/2019 Last Posted : 09/11/2019

	BHR		Fringe Benefit Payments					Irrevocable Fund		Total PWR	Overtime Rate	
			H&W	Pension	App Tr.	Vac.	Annuity	Other	LECET (*)			MISC (*)
Classification												
Truck Driver CLASS 1 4 wheel service, dump, and batch trucks, Oil Distributor - Asphalt Distributor-Tandems	\$28.04		\$7.00	\$7.90	\$0.20	\$0.00	\$0.00	\$0.00	\$0.00	\$0.00	\$43.14	\$57.16
Apprentice	Percent											
First 6 months	80.00	\$22.43	\$7.00	\$7.90	\$0.20	\$0.00	\$0.00	\$0.00	\$0.00	\$0.00	\$37.53	\$48.75
7-12 months	85.00	\$23.83	\$7.00	\$7.90	\$0.20	\$0.00	\$0.00	\$0.00	\$0.00	\$0.00	\$38.93	\$50.85
13-18 months	90.00	\$25.24	\$7.00	\$7.90	\$0.20	\$0.00	\$0.00	\$0.00	\$0.00	\$0.00	\$40.34	\$52.95
19-24 months	95.00	\$26.64	\$7.00	\$7.90	\$0.20	\$0.00	\$0.00	\$0.00	\$0.00	\$0.00	\$41.74	\$55.06
25-30 months	100.00	\$28.04	\$7.00	\$7.90	\$0.20	\$0.00	\$0.00	\$0.00	\$0.00	\$0.00	\$43.14	\$57.16

Special Calculation Note : No special calculations for this skilled craft wage rate are required at this time.

Ratio :

3 Journeymen to 1 Apprentice

Jurisdiction (* denotes special jurisdictional note) :

ADAMS, ALLEN, ASHLAND, ASHTABULA, ATHENS, AUGLAIZE, BELMONT, BROWN, BUTLER, CARROLL, CHAMPAIGN, CLARK, CLERMONT, CLINTON, COLUMBIANA, COSHOCTON, CRAWFORD, DARKE, DEFIANCE, DELAWARE, ERIE, FAIRFIELD, FAYETTE, FRANKLIN, FULTON, GALLIA, GREENE, GUERNSEY, HAMILTON, HANCOCK, HARDIN,

HARRISON, HENRY, HIGHLAND, HOCKING,
HOLMES, HURON, JACKSON, JEFFERSON,
KNOX, LAWRENCE, LICKING, LOGAN,
LORAIN, LUCAS, MADISON, MAHONING,
MARION, MEDINA, MEIGS, MERCER, MIAMI,
MONROE, MONTGOMERY, MORGAN,
MORROW, MUSKINGUM, NOBLE, OTTAWA,
PAULDING, PERRY, PICKAWAY, PIKE,
PORTAGE, PREBLE, PUTNAM, RICHLAND,
ROSS, SANDUSKY, SCIOTO, SENECA, SHELBY,
STARK, SUMMIT, TRUMBULL, TUSCARAWAS,
UNION, VAN WERT, VINTON, WARREN,
WASHINGTON, WAYNE, WILLIAMS, WOOD,
WYANDOT

Special Jurisdictional Note :

Details :

** Asphalt - Oil spray bar man when operating from cab shall receive \$0.20 cents per hour above their Basic Hourly Rate.

Prevailing Wage Rate Skilled Crafts

Name of Union: Truck Driver Bldg & HevHwy Class 2
Locals 20,40,92,92b,100,175,284,438,377,637,908,957

Change # : LCRO1-2019-fbBldgHevHwy

Craft : Truck Driver Effective Date : 10/16/2019 Last Posted : 10/16/2019

	BHR		Fringe Benefit Payments					Irrevocable Fund		Total PWR	Overtime Rate	
			H&W	Pension	App Tr.	Vac.	Annuity	Other	LECET (*)			MISC (*)
Classification												
Truck Driver CLASS 2 Tractor Trailer-Semi Tractor Trucks-Pole Trailers-Ready Mix Trucks-Fuel Trucks-Asphalt-Oil Spray bar men- 5 Axle & Over -Belly Dumps-End Dumps-Articulated Dump Trucks-Low boys-Heavy duty Equipment (irrespective of load carried) when used exclusively for transportation- Truck Mechanics (when needed)	\$28.46		\$7.00	\$7.90	\$0.20	\$0.00	\$0.00	\$0.00	\$0.00	\$0.00	\$43.56	\$57.79
Apprentice	Percent											
First 6 months	80.00	\$22.77	\$7.00	\$7.90	\$0.20	\$0.00	\$0.00	\$0.00	\$0.00	\$0.00	\$37.87	\$49.25
7-12 months	85.00	\$24.19	\$7.00	\$7.90	\$0.20	\$0.00	\$0.00	\$0.00	\$0.00	\$0.00	\$39.29	\$51.39
13-18 months	90.00	\$25.61	\$7.00	\$7.90	\$0.20	\$0.00	\$0.00	\$0.00	\$0.00	\$0.00	\$40.71	\$53.52
19-24 months	95.00	\$27.04	\$7.00	\$7.90	\$0.20	\$0.00	\$0.00	\$0.00	\$0.00	\$0.00	\$42.14	\$55.66
25-30 months	100.00	\$28.46	\$7.00	\$7.90	\$0.20	\$0.00	\$0.00	\$0.00	\$0.00	\$0.00	\$43.56	\$57.79

Special Calculation Note : No special calculations for this skilled craft wage rate are required at this time.

Ratio :

3 Journeymen to 1 Apprentice

Jurisdiction (* denotes special jurisdictional note) :

ADAMS, ALLEN, ASHLAND, ASHTABULA, ATHENS, AUGLAIZE, BELMONT, BROWN, BUTLER, CARROLL, CHAMPAIGN, CLARK, CLERMONT, CLINTON, COLUMBIANA, COSHOCTON, CRAWFORD, DARKE, DEFIANCE, DELAWARE, ERIE, FAIRFIELD, FAYETTE, FRANKLIN, FULTON, GALLIA, GREENE, GUERNSEY, HAMILTON, HANCOCK, HARDIN, HARRISON, HENRY, HIGHLAND, HOCKING, HOLMES, HURON, JACKSON, JEFFERSON, KNOX, LAWRENCE, LICKING, LOGAN, LORAIN, LUCAS, MADISON, MAHONING, MARION, MEDINA, MEIGS, MERCER, MIAMI, MONROE, MONTGOMERY, MORGAN, MORROW, MUSKINGUM, NOBLE, OTTAWA, PAULDING, PERRY, PICKAWAY, PIKE, PORTAGE, PREBLE, PUTNAM, RICHLAND, ROSS, SANDUSKY, SCIOTO, SENECA, SHELBY, STARK, SUMMIT, TRUMBULL, TUSCARAWAS, UNION, VAN WERT, VINTON, WARREN, WASHINGTON, WAYNE, WILLIAMS, WOOD, WYANDOT

Special Jurisdictional Note :

Details :

** Asphalt - Oil spray bar man when operating from cab shall receive \$0.20 cents per hour above their Basic Hourly Rate.

SECTION VII

Contract No. 20-01

ODOT PID 109613: WAR-CR21-0.23-0.41

CONTRACT NO. 20-01

**ODOT PID 109613: WAR-CR21-0.23-0.41,
(aka Mason-Montgomery Rd Access Management Project)
DEERFIELD TWP
WARREN COUNTY, OHIO**

THIS AGREEMENT, made and entered into this ____ day of _____ in the year Two Thousand and Sixteen, 20202020, by and between the Warren County Transportation Improvement District, **210 W Main Street, Lebanon, Ohio 45036**, hereafter designated as the WCTID, and _____, hereinafter designated as the Contractor.

WITNESSETH: That the Contractor has agreed, and by these presents does agree with the WCTID for the consideration herein below mentioned, to furnish at Contractor's own proper cost and expense all necessary materials and labor of every description, and to carry out complete in good, firm and timely substantial manner the following project in accordance with the surveys, plats, plans, cross-sections and profiles and specifications on file in the office of the said WCTID and in accordance with the specifications and conditions hereinbefore and hereinafter set forth, all of which are made a part hereof as if totally rewritten herein:

ODOT PID 109613: **WAR-CR21 0.23-0.41 Mason-Montgomery Rd Access Management Project**, (aka Western Row – Phase 1)

The project includes the furnishing of all labor, equipment, and materials needed to construct ODOT PID 109613: **WAR-CR21 0.23-0.41 Mason-Montgomery Rd Access Management Project**, (aka Western Row – Phase 1).

The provisions contained in the "Notice to Contractors," the "General Instructions," the "Bid Proposal," Form FHWA-1273 and the "General Provisions" (including any conditions or specifications incorporated therein), as well as any provisions in the surveys, plats, cross-sections, profiles, and other associated plans for this work on file in the offices of the WCTID, are also hereby combined, and incorporated by reference thereto, as part of this agreement.

The Contractor shall pay into the State Insurance Fund the amount of premium determined and fixed by the Industrial Commission of Ohio, promptly when due, or elect to pay compensation direct and contribute to the surplus of the fund as provided by law. The Contractor and his Surety agree to defend and indemnify WCTID, WCEO, Warren County and the Township against liability and loss by reason of the breach of the obligation of this paragraph and agree that it shall run to the benefit of the Industrial Commission of Ohio and the State Insurance Fund for the recovery of premiums that should have been paid. All of the foregoing provisions of this paragraph shall be equally binding upon each sub-contractor whose performance thereof is warranted by the Contractor who employs such sub-contractor. The Warren County Transportation Improvement District may require of the Contractor, as a condition of permitting the beginning or continuance of work, a Certificate of Compliance with the paragraph issued by the Industrial Commission of Ohio.

In consideration whereof, the WCTID hereby agrees and promises to pay to the Contractor, at the times, under the conditions and in the manner provided in the specifications, and in full of all compensation for material furnished or work done thereunder, at the unit prices, or lump sum, as stated in the proposal, the sum of approximately:

TOTAL AMOUNT: _____

IN WITNESS WHEREOF, the said WCTID has caused its name to be signed and the corporate seal to be hereto affixed by the WCTID and the Contractor, the day and the year aforesaid.

CONTRACTOR

**WARREN COUNTY TRANSPORTATION DISTRICT,
WARREN COUNTY, OHIO**

(COMPANY/CORPORATION NAME)

(Chair)

(SIGNATURE OF OWNER/AGENT)

(Secretary-Treasurer)

(TITLE/POSITION)

APPROVED AS TO FORM:

WCTID Legal Counsel

Date

SECTION IX
SPECIAL PROVISIONS/TECHNICAL SPECIFICATION

SPECIAL PROVISIONS/TECHNICAL SPECIFICATION

WAR-CR21-0.23-0.41, (aka Mason-Montgomery Rd Access Management Project) DEERFIELD TWP, WARREN COUNTY, OHIO

ODOT PID 109613

The 2019 Ohio Department of Transportation Construction and Material Specifications and the Supplemental Specifications shall govern this project unless stated otherwise by the Warren County Transportation Improvement District, herein referred to as "Engineer" and "Project Engineer".

It is required that the bidder be an ODOT pre-qualified Contractor to complete the construction work required in these Bid Documents. The Contractor, Sub-Contractor, and Fabricators must meet or exceed the ODOT Minimum Skills Requirements for all Work Types involved in this project.

Conflicting Items in Bid Documents

Whenever the Technical Specifications and Bid Proposal Quantities differ from the Construction Plans the Technical Specifications and Bid Proposal Quantities shall control for the bidding of this project.

Project Responsibilities

This project is bid and funded by the Warren County Transportation Improvement District. The Warren County Engineer's Office will be providing the construction management of this project. Further Warren County Transportation Improvement District has directly hired Prime AE to act as their agent for daily quality assurance and quality control.

Operations Schedule

The Contractor shall advise and coordinate all work with the Engineer. A detailed schedule of operations shall be furnished by the Contractor to the Engineer and shall list the order of operations and the time frame for the completion of each item of work. The Engineer and the Owner prior to the beginning of the work shall approve the schedule of operations. Changes to said schedule are to be issued in writing and approved by the Engineer before operations are changed or rescheduled. The Contractor shall schedule operations so that the improved areas have had sufficient time to cure, set and/or harden before the area is opened to traffic or use. The Contractor shall be responsible for the immediate repair of the improved area if any damage is done by traffic. The Contractor shall also be responsible for the immediate rectification of problems created in areas outside of the improved areas attributable to the failure of the improved area, i.e., the tracking of materials into unimproved areas.

Preconstruction Meeting

Prior to the commencement of the construction activities, the Warren County Transportation Improvement District will arrange a meeting between the Contractor, the Warren County Transportation Improvement District, and Warren County Engineer. The time, date and location of said meeting will be determined after the awarding of the contract, and all parties will be notified by the Warren County Transportation Improvement District. At the preconstruction meeting the Contractor shall submit to the Project Engineer a construction schedule, list of subcontractors, list of suppliers, and a completed Ohio EPA Co-Permittee Notice of Intent (NOI).

Project Start Date

The Contractor shall begin the construction once a written notice-to-proceed has been given by the Warren County Transportation Improvement District and a preconstruction meeting with the Warren County Engineer has been held. The anticipated first day of construction is Monday, May 4, 2020.

Working Restrictions

No work shall be done between 6:00 a.m. and 10:00 p.m. Monday through Friday or during holidays. All work shall be performed as "night work".

Payment of Work

Contractor Estimates shall not be submitted more than once a month to the Warren County Transportation Improvement District for work included in the Contract between the Warren County Transportation Improvement District and the Contractor. Estimates will be generated monthly by PRIME AE based on inspected and accepted work performed on the project. The Monthly Payment is Approximate, and all partial estimates and payments are subject to correction in the final estimate and payment.

Payment for work and materials shall in no way prevent later rejection when defective work or material is discovered or constitute acceptance under 109.11 or 109.12.

Retainage and Affidavits

The contractor shall provide the Warren County Transportation Improvement District with affidavits stating that all subcontractors and suppliers for this project have been paid in full in accordance with Item 109.08. A percentage of the original contract bid amount shall be retained on this project. Until 50% of the original contract has been performed, 8% of the amount of work performed will be retained. Once 50% of the contract has been performed and thereafter, a total of 4% of the original contract bid amount will be retained. The entire retainage will be released to the Contractor after the final inspection has been performed, after the Warren County Transportation Improvement District has accepted the construction and after all affidavits have been submitted to the Warren County Transportation Improvement District by the Contractor.

Change Orders

No change orders involving performance or nonperformance contract quantities of project materials shall be processed without direct approval by the Warren County Transportation Improvement District.

Storage of Construction Materials

The Contractor shall obtain prior approval of the Owner and/or Engineer for the locations to be used for the temporary storage of construction materials, tools, and/or machinery. All such materials, tools, and machinery shall be neatly and compactly piled in such a manner as to cause the least inconvenience to the property owners and to traffic. Under no circumstances shall existing drainage courses be blocked or water hydrants, valves, or meter pits covered.

Protection of Areas Outside of Work Limits

The Contractor shall be responsible for the protection of areas outside of the designated work limits, but which may be adjacent to those work limits. This will include those areas used by construction traffic for access to and from the work areas. Where the Engineer determines that the Contractor's operations have been responsible for damage to areas outside of the work limits, the Contractor shall be responsible for the repair of the area subject to the approval of the Engineer. No additional compensation will be due to the Contractor for any repair of these areas.

Debris Removal

The Contractor will be responsible for removal from the site of all construction debris material. All debris material shall be disposed of in a proper manner and shall be as directed by any applicable local, state or federal regulations.

Utility Notification

The Contractor shall notify at least 48 hours before breaking ground all public and/or private service corporation having wires, poles, conduits, manholes, or other structures that may be affected by the construction on this project, including all structures which are affected and not shown on the plans. Owners of underground utilities, which are members of OUPS, can be notified by calling 1-800-362-2764. Non-member underground utility owners must be called directly.

Utility Adjustments

The Contractor shall adjust to proposed grade all existing utility facilities, i.e. manholes, catch basins, valves, boxes, etc., prior to the commencement of paving operation. This shall include utility facilities, not shown on the plan, which may be found to be located within the pavement area. Work performed on the utility facilities shall be in strict accordance with the specifications of the applicable utility owner and shall be performed under the direction, supervision and inspection of said owner.

Existing Pipe

The location, size, type and depth of all existing pipe are shown as according to the best information. The Engineer will not be responsible for any variations found during construction.

Where the plans provide for conduit to be connected to, or to cross either over or under, or close to an existing underground structure, it shall be the responsibility of the Contractor to locate the existing structure, both as to line and grade, before he starts to lay the proposed conduit, in order to assure compatibility of line and grade of the proposed conduit. Payment for all operations described above shall be included in the unit price bid for the pertinent conduit item.

Grading at Inlets and Outfalls of Proposed Conduits

The cost of the necessary reconstruction and/or re-grading of swales or disturbed areas at the inlets and outfalls of all proposed conduits shall be included in the price bid for the pertinent conduit and inlet items.

Restoration of Areas Disturbed by Drainage Facilities

Soil areas disturbed by construction of underdrains, trench drains, catch basins or other drainage facilities shall be re-graded to drain properly and then restored. The cost of restoration of these soil areas is to be per the unit bid for the pertinent item. Pavement areas disturbed by the construction of the drainage facilities will be restored as per the asphalt pavement repair detail. Payment for the restoration of these areas will be at the unit price bid for the pertinent item.

Conduit End Treatment

Immediately after placement of any conduits, the Contractor shall construct the end treatments required by the plans at both the outlet and inlet ends. This shall include headwalls, concrete riprap, rock channel protection, sodding, etc.

Maintenance of Sewer Flows

The Contractor shall conduct his operations so as to maintain at all times storm water and sewer flows through existing facilities to remain in place and through existing facilities to be replaced until new facilities are completed and placed in use.

Conduit, Drainage and Utility Items

Unless otherwise specified on the plans, the unit price bid for the pertinent conduit, drainage and/or utility item shall include the cost of all-necessary appurtenances, connections, fittings, plugs, tees, collars, etc.

Unless otherwise noted on the plans, the unit price for the pertinent conduit, drainage and/or utility item is to include the costs involved in the excavation of the trench in unclassified material, the supplying and placing of the required bedding material and the backfilling of the trench with the specified material to the appropriate subgrade elevations.

The contractor shall take precaution while excavating for pipe near existing utilities. If necessary, the contractor shall hand dig in areas where proposed pipe is to be installed near an existing utility. The Contractor shall hold the Warren County Transportation Improvement District harmless of liabilities which may arise from the damaging of existing utilities. The payment for hand digging in areas near existing utilities shall be paid for under the price bid for the pertinent item.

Testing of Construction Materials

PRIME AE Group will perform and/or manage all quality assurance and quality control testing performed on the project as required by the ODOT Manual of Procedures. The Contractor shall be responsible for the scheduling of all testing as per the general testing requirements specified in the ODOT MOP or as modified by the Engineer. The Engineer shall be responsible for the costs incurred in the testing of the construction materials both on site and at the plant. However, the Contractor shall note that he will be responsible for any and all costs incurred by the scheduling and/or rescheduling of the testing firm's activities by the Contractor and the subsequent delay and/or cancellation of said activities due to the delay and/or cancellation of the scheduled construction by the Contractor.

"Or Approved Equal" Items

In the preparation of these documents and plans, several proprietary products have been specified. In all such cases, it is indicated by the words "Or Approved Equal." However, the Contractor must be aware that, before commencement of construction, he must provide information to the Engineer concerning the substituted product and that the Engineer must approve the offered product as being equal to the specified product. Unless otherwise modified by the Engineer, proprietary products are to be installed and/or constructed in strict compliance with the pertinent manufacturer's specifications.

Item 201 - Clearing and Grubbing

This work shall consist of clearing, grubbing, scalping, removal of trees and stumps, and removing and disposing of all vegetation and debris within the limits of construction, except such objects as are to remain or are to be removed in accordance with other sections of these specifications. The Contractor shall keep clearing to a minimum removing only what is necessary to complete construction. Payment for the work listed above shall be included in the Lump Sum bid price for Item 201 Clearing and Grubbing.

Item 202 – Removals

This work shall consist of the removal, wholly or in part, and satisfactory disposal of all buildings, fences, guardrails, structures, old pavements, abandoned pipe lines, storage tanks, septic tanks, privy vaults, and any other obstructions which are not designated or permitted to remain, except for the obstructions to be removed and disposed of under other items in the contract. It shall also include the salvaging of designated materials and backfilling the resulting trenches, holes, and pits.

Item 254 – Pavement Planning

This work shall conform to the 2019 Ohio Department of Transportation Construction and Material Specifications and shall be completed as directed by the Engineer. A butt joint shall be constructed at each start/stop locations. Each butt joint shall provide a smooth transition and shall also be properly sealed. The Contractor shall be responsible for removing and disposing of the cuttings. The cost of this work shall be paid for at the unit price bid per S.Y. of Item 254 Pavement Planning.

Asphalt Concrete

All material furnished and work performed shall conform to the 2019 Ohio Department of Transportation Construction and Material Specifications (ODOT CMS) for Item 301 Asphalt Concrete Base, Item 448 Asphalt Concrete Intermediate Course, and Item 448 Asphalt Concrete Surface Course.

The Contractor shall supply the Warren County Transportation Improvement District with a weigh ticket for each load of material placed. Periodic asphalt samples will be obtained for test purposes and an independent testing laboratory will perform tests.

No material shall be placed upon collected water. Asphalt surfaces shall be clear of dirt and debris prior to the placing of each subsequent lift. The Contractor shall adhere to the judgment of the Warren County Transportation Improvement District's designated representatives.

The Contractor's attention is directed to Section 401.14 of the ODOT Specifications and he is hereby instructed that requirements for preparation of asphalt pavement to be resurfaced will be adhered to, and cost of any and all cleaning is to be included in the unit price bid for Item 301 and Item 442.

Butt Joints - A butt joint shall be constructed by grinding/planing existing pavement at each start/stop location, or where newly placed asphalt abuts existing pavement or curb at intersections or cross roads. All grinding/ planing shall be in accordance with Item 254 Pavement Planning, Bituminous. The butt joints shall be constructed by grinding/planing the existing pavement for a length of 6 feet, varying in depth from 2" to 0". The newly formed joint shall be properly installed so as to provide a smooth transition and shall also be properly sealed. The cost of constructing each butt joint by pavement planing/grinding shall be included and paid for in Item 442 Asphalt Concrete.

Item 455 – Quality Control Plan, Testing and Assurance for QC/QA Concrete

The Contractor shall develop and submit a Quality Control Plan (QCP) for all QC/QA concrete items included in the proposal. The Contractor shall be responsible the Quality Control (QC) for all the QC/QA concrete items. The Warren County Transportation Improvement District has acquired the services of Prime AE Group, Inc. to provide the Quality Assurance (QA) for all QC/QC concrete items.

Item 611 - Pipe Culverts, Sewers and Drains, Ex. Downspouts, Ex. Farm Drains

This work shall consist of the construction or reconstruction of pipe culverts, sewers and drains hereinafter referred to as Type A, Type B, Type C, Type D, Type E and Type F Conduit. The work shall be in accordance with these specifications and in reasonably close conformity with the lines and grades shown on the plans or established by the Engineer. This work shall include the following: excavating for pipe and foundations for same, including clearing and grubbing and the removal of all materials necessary for placing the pipe except removals listed separately; furnishing and placing granular or concrete bedding and granular backfill as required; constructing and subsequently removing all necessary cofferdams, cribs and sheeting; pumping and dewatering; sealing or banding all pipe joints where required; furnishing and installing all necessary pipe bends and branches of a type at least equal to the conduit of which they become a part; joining to existing and proposed appurtenances as required; performing leakage tests as specified; restoration of disturbed facilities and surfaces; and providing erosion control pads and animal guards on underdrain and farm drain outlets.

Item 611 - Manholes, Catch Basins and Inlets

The Contractor is responsible for supplying, delivering and installing the Precast Concrete Sections and the related material. All related material shall be included with the bid and shall be provided by the Contractor. The Contractor shall furnish, unload, assemble, and install the Precast Concrete Sections and all related material at the location shown on the plans. All castings for manholes, catch basins and inlets shall conform to those specified in the standard construction drawings or as specified by the Engineer. All castings which might be subject to vehicle traffic shall be of the heavy-duty grade. Grated inlet tops shall be placed as specified on the plans. Top of casting elevations are subject to final adjustments as approved by the Engineer.

All castings used shall be subject to the final approval of the Engineer.

Item 614 - Maintaining Traffic

Traffic control shall be the sole responsibility of the Contractor. The Warren County Transportation Improvement District shall be held harmless from liabilities caused by improper traffic control by the Contractor. The contractor shall indemnify the Warren County Transportation Improvement District from any and all liabilities due to improper maintenance of traffic. All road construction signs shall also be the responsibility of the Contractor. All traffic control shall conform to the Ohio Manual of Uniform Traffic Control Devices (OMUTCD) as well as the Ohio Department of Transportation Standards at all times.

Any devices that are determined by the Engineer to be substandard shall be repaired to the satisfaction of the Engineer or shall be immediately removed from the site and replaced with acceptable devices. Any temporary traffic control devices that are determined by the Engineer to have become substandard during the course of the project shall be removed from the jobsite and immediately replaced by devices meeting the approval of the Engineer.

The contractor shall provide and maintain all signs, barricades, labor, flagmen, steel plates, etc. for all work on this project. The Contractor shall notify the Warren County Transportation Improvement District

two (2) weeks prior to any lane closure. Any conflicting markings shall be removed or covered in accordance with Item 614.

Methods of maintaining traffic shall conform to the Manual of Uniform Traffic Control Devices and Item 614 of the ODOT Specifications. Payment for the work listed above shall be included in the Lump Sum price bid for Item 614 Maintaining Traffic.

Item 623 - Construction Layout Stakes

All centerline of survey and property corner monumentation that is disturbed during construction shall be reset by a Professional Surveyor. Payment for the construction layout and work listed above shall be included in the Lump Sum price bid for Item 623 Construction Layout Stakes.

Item 644 - Pavement Marking

The construction plans do not accurately detail this but all pavement marking in this project shall be Item 644 Thermoplastic Pavement Marking. All pavement marking material and work shall comply with Item 641 Pavement Marking-General and Item 644 Thermoplastic Pavement Marking in the 2019 ODOT Construction and Materials Specifications.



PN 095 – 03/30/2020 Potential Impacts and Delays Due to COVID-19

In an effort to anticipate the potential impacts to the Project caused by the COVID-19 threat and in following direction from the Governor and other authorities, the Contractor is on notice of the need to comply with all federal, state and local orders generated to prevent the spread of contagious or infectious diseases, including the Stay at Home Order from the Ohio Director of Health dated March 22, 2020, and subsequent orders, located through the following website:

<https://coronavirus.ohio.gov/wps/portal/gov/covid-19/home/public-health-orders/directors-order-to-stay-at-home>

Contractor is on notice that the Project is considered essential and that the contractor and his employees, subcontractors and suppliers are considered essential businesses and performing essential functions as defined under the Stay at Home Order.

Notwithstanding any other provisions of the contract documents, in the event of project delay or impacts to performance due to a voluntary or mandatory COVID-19 virus Directives, Orders, quarantine or closure directed by government authorities, either party may, by providing notice to the other party as required under CMS 108.02(F), extend the Completion Date for a period of up to thirty (30) days. Extensions under this paragraph shall be considered an excusable, non-compensable delay in accordance with CMS 108.06(B). If any portion of the Work is still not able to be performed upon the expiration of the extension, either party may provide notice to the other party requesting a termination for convenience under 108.09. The termination for convenience remains at the sole discretion of the LPA's Person in Responsible Charge in conjunction with the Office of Local Programs.

The Contractor and LPA will exercise best efforts to utilize remote services to perform Work that otherwise cannot be performed in person due to a voluntary or mandatory COVID19 virus quarantine, closure, or impact as directed by Stay at Home Order.

Impacts to the Project generated by the Stay at Home Order shall not be considered an "issue" under 108.02 (F) for Projects sold after the date of this Note. Contractors are on notice that their bids should include any impacts they foresee or should have reasonably foreseen due to the Stay at Home Order or existing or reasonably foreseeable orders by any other federal, state or local official.

If any emergency order or declaration of any government official is lifted at any time, the LPA will provide written notice to the Contractor that this Note shall be considered void thirty (30) days after receipt of the written notice. If the Stay at Home Order from the Ohio Director of Health dated March 22, 2020 is lifted at any time, this Note shall be considered null and void thirty (30) days after the lifting of those orders.

4A Utility Notes

ODOT PID 109613: WAR-CR21-0.23-0.41,
(aka Mason-Montgomery Rd Access Management Project)
DEERFIELD TWP
WARREN COUNTY, OHIO

Bidders are advised that due to the scope, limits, and nature of this project no utility relocation is necessary.

G:\Cincinnati\DCS\Project\SRN\60603899_WCID_CR21\001\WAR\09613\Design\Roadway\Sheets\09613_GTO01.dgn Sheet 2/11/2020 8:56:03 AM christopher.jykins



LOCATION MAP

LATITUDE: N39°17'45" LONGITUDE: W84°18'55"



PORTION TO BE IMPROVED	_____
INTERSTATE HIGHWAY	_____
FEDERAL ROUTES	_____
STATE ROUTES	_____
COUNTY & TOWNSHIP ROADS	_____
OTHER ROADS	_____

DESIGN DESIGNATION

CURRENT ADT (2018)	51,380
DESIGN YEAR ADT (2040)	53,540
DESIGN HOURLY VOLUME (2040)	3,970
DIRECTIONAL DISTRIBUTION	52%
TRUCKS (24 HOUR B&C)	4%
DESIGN SPEED	35 MPH & 45 MPH
LEGAL SPEED	35 MPH & 45 MPH
DESIGN FUNCTIONAL CLASSIFICATION:	
06 MINOR COLLECTOR (URBAN)	
NHS PROJECT	NO

DESIGN EXCEPTIONS

NONE

UNDERGROUND UTILITIES
Contact Two Working Days Before You Dig

OHIO811, 8-1-1, or 1-800-362-2764
(Non-members must be called directly)

PLAN PREPARED BY:
AECOM
525 VINE STREET, SUITE 1800 CINCINNATI, OHIO 45202
(513) 651-3440

ENGINEERS SEAL:

SIGNED: *David L. Wormald*
DATE: 7-10-20

STATE OF OHIO
DEPARTMENT OF TRANSPORTATION
WAR-21-0.23
MASON-MONTGOMERY RD.
DEERFIELD TOWNSHIP
WARREN COUNTY

INDEX OF SHEETS:

TITLE SHEET	1
TYPICAL SECTIONS	2
GENERAL NOTES	3
MAINTENANCE OF TRAFFIC	4-5
GENERAL SUMMARY	6
PLAN	7-8
PAVEMENT MARKING AND SIGNING PLAN	9

STANDARD CONSTRUCTION DRAWINGS				SUPPLEMENTAL SPECIFICATIONS		SPECIAL PROVISIONS	
BP-3.1	1/17/20	TC-41.20	10/18/13	800-2019	1/17/20		
		TC-41.30	10/18/13				
RM-3.1	7/20/18	TC-42.20	10/18/13	821	4/20/12		
		TC-52.20	7/20/18	832	10/19/18		
MT-95.31	4/19/19	TC-65.10	7/21/17	921	4/20/12		
MT-95.32	4/19/19	TC-65.11	7/21/17				
MT-95.60	4/19/19	TC-71.10	1/19/18				
MT-95.61	4/19/19						
MT-97.12	1/20/17						
MT-98.28	1/17/20						
MT-99.20	4/19/19						
MT-101.90	7/21/17						
MT-105.10	7/19/13						

PROJECT DESCRIPTION

CONSTRUCTION OF A NEW CONCRETE MEDIAN ON MASON-MONTGOMERY ROAD (CR-21) TO CONTROL ACCESS TO EXISTING COMMERCIAL DRIVEWAYS NORTH OF ESCORT DRIVE. MILL AND OVERLAY EXISTING PAVEMENT, REPLACE SIGNS AND PAVEMENT MARKINGS.

EARTH DISTURBED AREAS

PROJECT EARTH DISTURBED AREA: 0.0 ACRES
ESTIMATED CONTRACTOR EARTH DISTURBED AREA: 0.125 ACRES
NOTICE OF INTENT EARTH DISTURBED AREA: NOT REQUIRED

2019 SPECIFICATIONS

THE STANDARD SPECIFICATIONS OF THE STATE OF OHIO, DEPARTMENT OF TRANSPORTATION, INCLUDING SUPPLEMENTAL SPECIFICATIONS LISTED IN THE PLANS AND CHANGES LISTED IN THE PROPOSAL SHALL GOVERN THIS IMPROVEMENT.

I HEREBY APPROVE THESE PLANS AND DECLARE THAT THE MAKING OF THIS IMPROVEMENT WILL NOT REQUIRE THE CLOSING TO TRAFFIC OF THE HIGHWAY AND THAT PROVISIONS FOR THE MAINTENANCE AND SAFETY OF TRAFFIC WILL BE AS SET FORTH ON THE PLANS AND ESTIMATES.

APPROVED: *Neil F. Junion*
DATE 3/10/20 WARREN COUNTY ENGINEER

FEDERAL PROJECT NO.	E190562
PID NO.	109613
CONSTRUCTION PROJECT NO.	N/A
RAILROAD INVOLVEMENT	NONE
WAR-21-0.23	WAR-21-0.23

G:\Cincinnati\Projects\TRN\60603899_WCID_CR2\0001\WAR\09613\Design\Roadway\Sheets\09613_GY001.dgn_Sheet 2/11/2020 8:56:11 AM christopher.jykins

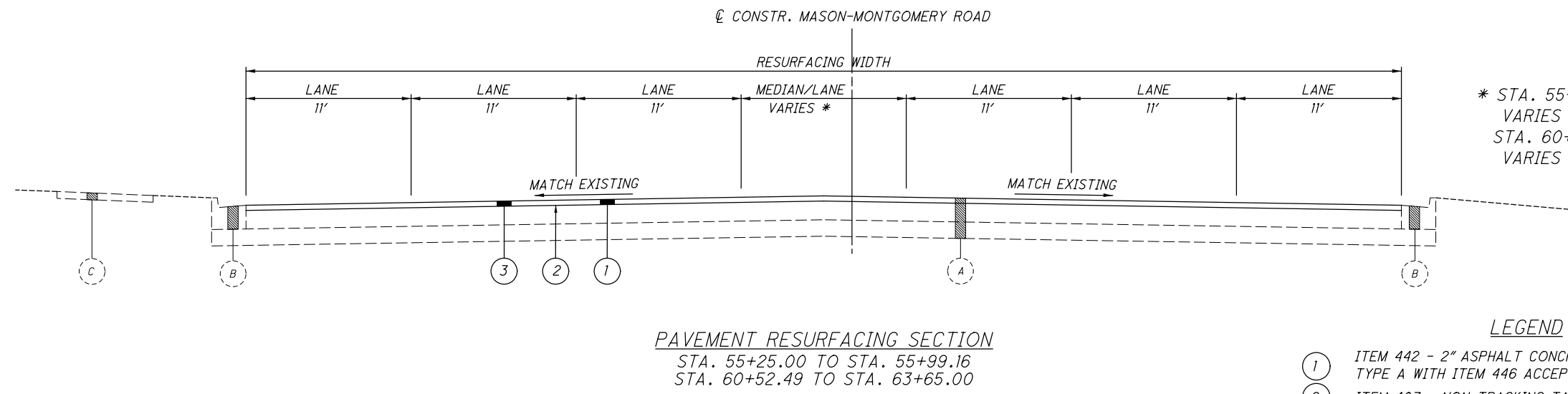
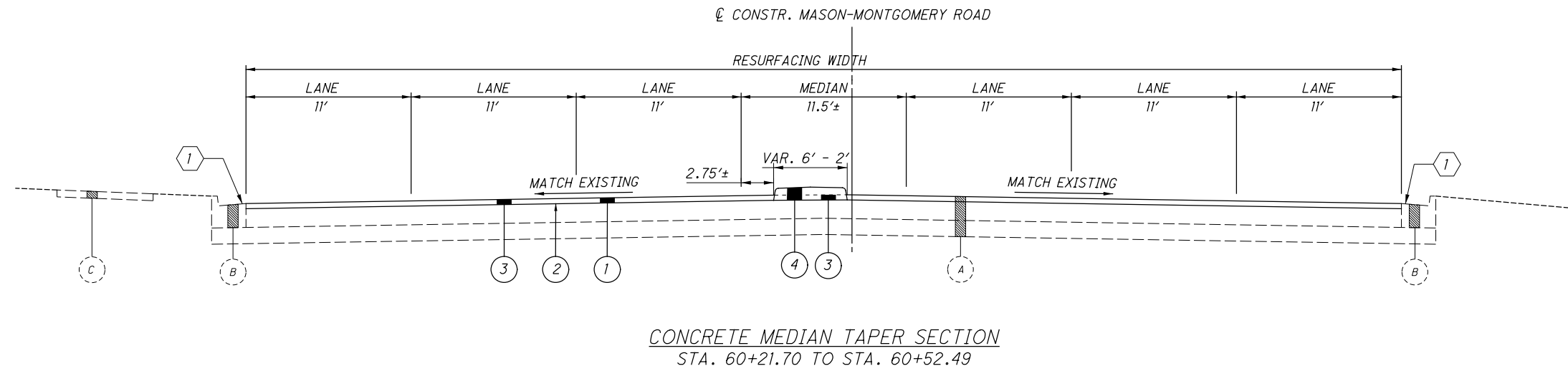
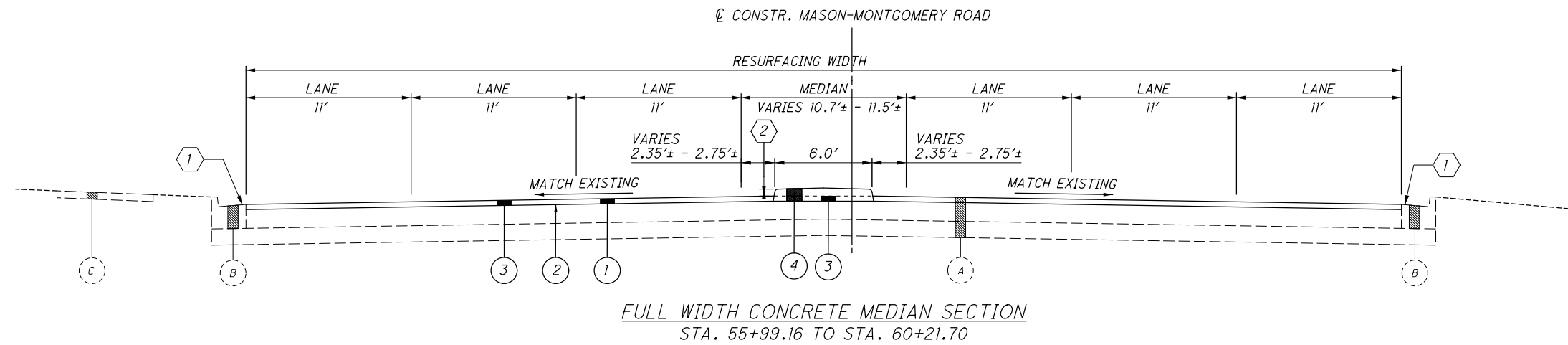

* STA. 55+25.00 TO STA. 55+99.16, VARIES 10.5' ± - 10.7' ±
STA. 60+52.49 TO STA. 63+65.00, VARIES 11.5' ± - 12.0' ±

NOTE:
(1) CONTRACTOR TO USE EXTREME CAUTION DURING PLANING AND RESURFACING OPERATIONS TO NOT DAMAGE EX. CURBING AND/OR COMBINATION CURB & GUTTER. ANY DAMAGES CAUSED BY THE CONTRACTOR, AS DETERMINED BY THE ENGINEER, SHALL BE APPROPRIATELY AND SATISFACTORILY REPAIRED AT THE CONTRACTOR'S SOLE EXPENSE.

- LEGEND**
- (1) ITEM 442 - 2" ASPHALT CONCRETE SURFACE COURSE, 12.5MM, TYPE A WITH ITEM 446 ACCEPTANCE
 - (2) ITEM 407 - NON-TRACKING TACK COAT (0.09 GAL./SY)
 - (3) ITEM 254 - PAVEMENT PLANING, ASPHALT CONCRETE, 2"
 - (4) ITEM 609 - CONCRETE MEDIAN
 - (A) EXISTING PAVEMENT WITH ASPHALT CONCRETE SURFACE
 - (B) EXISTING CURB AND GUTTER
 - (C) EXISTING WALK
 - (2) 6" TYPICAL, EXCEPT VARIES WITHIN LIMITS OF MEDIAN NOSE RAMP

G:\Cincinnati\DCS\Projects\TRN\60603899_WCID_CR2\ODOT\WAR\09613\Design\Roadway\Sheets\09613.GN001.dgn_Sheet 2/11/2020 8:56:12 AM christopher.jykins

UTILITIES

LISTED BELOW ARE ALL UTILITIES LOCATED WITHIN THE PROJECT CONSTRUCTION LIMITS TOGETHER WITH THEIR RESPECTIVE OWNERS. NO UTILITIES ARE TO BE DISTURBED.

CENTURYLINK
803 E. 12TH STREET
GREENVILLE, OH 45331
ATTN: DAVID KAPLAN
937-547-4255
DAVID.W.KAPLAN@CENTURYLINK.COM
NATIONALRELO@CENTURYLINK.COM

CHARTER COMMUNICATIONS
10920 KENWOOD ROAD
BLUE ASH, OH 45242
ATTN: KENT RIEGER
513-386-5499
KENT.RIEGER@CHARTER.COM

CINCINNATI BELL - AERIAL & PLACING
229 W. 7TH ST., BLDG. 121-900
CINCINNATI, OH 45202
ATTN: JASON NUNNALLEY
513-565-1418
JASON.NUNNALLEY@CINBELL.COM

CINCINNATI BELL TELEPHONE
221 E. 4TH STREET, BLDG. 121-900
CINCINNATI, OHIO 45201
ATTN: MARK CONNER
513-565-7043

CINCINNATI METROPOLITAN SEWER DISTRICT
1600 GEST STREET
CINCINNATI, OH 45204
ATTN: ROB FRANKLIN
513-557-7188
MSDUTILITYREVIEW@CINCINNATI-OH.GOV

DUKE ENERGY - ELECTRIC
2010 DANA AVENUE
ROOM EF 324
CINCINNATI, OHIO 45207
ATTN: TROY DITTMER
513-458-3844
TROY.DITTMER@DUKE-ENERGY.COM

DUKE ENERGY - GAS
139 E. 4TH STREET, ROOM 460A
CINCINNATI, OHIO 45202
ATTN: RICHARD HACKER
RICHARD.HACKER@DUKE-ENERGY.COM

GENERAL ELECTRIC (FIBER OPTIC)
8700 GOVERNOR'S HILL DRIVE
CINCINNATI, OHIO 45249
ATTN: JOHN DEHM
513-583-3488

GREATER CINCINNATI WATER WORKS
3845 EASTERN AVENUE
CINCINNATI, OHIO 45226
ATTN: KYLE BUCKLEY
513-591-7874
KYLE.BUCKLEY@GCWW.CINCINNATI-OH.GOV

LEVEL 3 COMMUNICATIONS
9490 MERIDIAN WAY
WEST CHESTER, OH 45069
ATTN: BRUCE MILLER
513-644-8943
BRUCE.MILLER@CENTURYLINK.COM
NATIONALRELO@CENTURYLINK.COM

MCI/VERIZON - FIBER OPTIC
120 RAVINE STREET
AKRON, OHIO 44303
ATTN: AL GUEST
330-253-8267
WARREN COUNTY WATER AND SEWER
406 JUSTICE DRIVE
LEBANON, OH 45036
ATTN: CHRIS BRAUSCH
513-695-1377

WINDSTREAM COMMUNICATIONS - KDL INC
929 MARTHA'S WAY
DAMAGE PREVENTION DEPARTMENT
HIAWATHA, IOWA 52233
ATTN: GAIL SCHMITZ
1-800-289-1901
LOCATE.DESK@WINDSTREAM.COM

THE LOCATION OF THE UNDERGROUND UTILITIES SHOWN ON THE PLANS ARE AS OBTAINED FROM THE OWNERS AS REQUIRED BY SECTION 153.64 O.R.C.

EXISTING PLANS

EXISTING PLANS FOR CR-21 MASON-MONTGOMERY RD. ARE AVAILABLE FOR REFERENCE FROM THE WARREN COUNTY ENGINEERS OFFICE.

PROFILE AND ALIGNMENT

PLACE THE PROPOSED PAVEMENT TO FOLLOW THE ALIGNMENT AND PROFILE OF THE EXISTING PAVEMENT.

PLACE THE PROPOSED ASPHALT CONCRETE OVERLAY WITH A UNIFORM THICKNESS OF 2.0" INCHES AS SHOWN ON THE TYPICAL SECTIONS.

SURVEYING PARAMETERS

SEE THIS SHEET FOR PROJECT CONTROL INFORMATION. A FIELD TOPOGRAPHIC SURVEY HAS NOT BEEN PERFORMED FOR THIS PROJECT. THE AS-BUILT LOCATIONS OF THE SOUTHBOUND CURB & GUTTER, SIGNS AND DRIVEWAYS SHALL BE FIELD VERIFIED BY THE CONTRACTOR.

USE THE FOLLOWING PROJECT CONTROL, VERTICAL POSITIONING, AND HORIZONTAL POSITIONING PARAMETERS FOR ALL SURVEYING:

PROJECT CONTROL

POSITIONING METHOD: ODOT VRS
MONUMENT TYPE: B

VERTICAL POSITIONING

ORTHOMETRIC HEIGHT DATUM: NAV 88
GEOID: 12A (CONUS)

HORIZONTAL POSITIONING

REFERENCE FRAME: NAD 83 (2011)
ELLIPSOID: GRS 80
MAP PROJECTION: LAMBERT
COORDINATE SYSTEM: STATE PLANE OH SOUTH
COMBINED SCALE FACTOR: 1.00009745
ORIGIN OF COORDINATE SYSTEM: 0.00, 0.00

USE THE POSITIONING METHODS AND MONUMENT TYPE USED IN THE ORIGINAL SURVEY TO RESTORE ANY MONUMENTS RELATED TO PRIMARY PROJECT CONTROL THAT ARE DAMAGED OR DESTROYED BY CONSTRUCTION ACTIVITIES. RESTORE THE DAMAGED OR DESTROYED MONUMENTS IN ACCORDANCE WITH CMS 623.

UNITS ARE IN U.S. SURVEY FEET.

WORK LIMITS

THE WORK LIMITS SHOWN ON THESE PLANS ARE FOR PHYSICAL CONSTRUCTION ONLY. PROVIDE THE INSTALLATION AND OPERATION OF ALL WORK ZONE TRAFFIC CONTROL AND WORK ZONE TRAFFIC CONTROL DEVICES REQUIRED BY THESE PLANS WHETHER INSIDE OR OUTSIDE THESE WORK LIMITS.

PROTECTION OF RIGHT-OF-WAY LANDSCAPING

PRIOR TO BEGINNING WORK, THE CONTRACTOR, THE PROJECT ENGINEER, AND A REPRESENTATIVE OF THE WARREN COUNTY ENGINEERS OFFICE WILL REVIEW AND RECORD ALL LANDSCAPING AND SIGNAGE ITEMS WITHIN THE RIGHT-OF-WAY (BOTH WITHIN AND OUTSIDE THE CONSTRUCTION LIMITS) A RECORD OF THIS REVIEW WILL BE KEPT IN THE PROJECT ENGINEER'S FILES. PRIOR TO FINAL ACCEPTANCE, A FINAL REVIEW OF LANDSCAPING ITEMS WILL BE MADE.

CONSTRUCT ALL ACTIVITIES, EQUIPMENT STORAGE, AND STAGING TO WITHIN THE CONSTRUCTION LIMITS. DO NOT USE PRIVATE PARKING LOTS OR DRIVEWAYS FOR PARKING OR STAGING OF EQUIPMENT AND MATERIALS.

ITEM 254 - PAVEMENT PLANING, ASPHALT CONCRETE

AN ESTIMATED QUANTITY OF ITEM 254 - PAVEMENT PLANING, ASPHALT CONCRETE HAS BEEN INCLUDED IN THE PLANS. THE APPROXIMATE DEPTH OF PAVEMENT PLANING SHALL BE TWO INCHES (2").

THE APPROXIMATE WIDTH OF THE PAVEMENT PLANING SHALL VARY.

ITEM 609, CONCRETE MEDIAN

THE CONCRETE MEDIAN SHALL BE AS SHOWN IN SCD RM-3.1, EXCEPT THAT THE WIDTH SHALL BE AS SHOWN ON THE PLAN SHEET AND THAT THE ASPHALT EMBEDMENT SHALL BE 2".

ITEM 620 DELINEATOR, POST SURFACE MOUNTED

THIS ITEM INCLUDES ALL LABOR, MATERIAL AND EQUIPMENT TO INSTALL FLEXIBLE SURFACE MOUNTED DELINEATOR POSTS TO THE CONCRETE MEDIAN AS SHOWN IN THE PLANS. THE POST SHALL BE FURNISHED BY AN APPROVED VENDOR ON THE ODOT QUALIFIED PRODUCTS LIST. THE BASE SHALL BE RIGIDLY MOUNTED TO THE CONCRETE SURFACE IN ACCORDANCE WITH MANUFACTURERS INSTRUCTIONS. PROVIDE HEAVY DUTY BASE MEETING NCHRP 350 REQUIREMENTS. POSTS SHALL BE 36" TALL, 3" WIDE, COLOR YELLOW. THE PROPOSED DELINEATOR SYSTEM SHALL BE APPROVED BY THE COUNTY ENGINEER IN WRITING 30 DAYS PRIOR TO INSTALLATION.

CALCULATED
CAL
CHECKED
DLW

GENERAL NOTES

WAR-21-0.23

3
9

G:\Cincinnati\DCS\Projects\TRN\60603899_WCID_CR2\000T\WAR\09613\Design\Roadway\Sheets\09613_GN002.dgn Sheet 2/11/2020 8:56:13 AM chrIstopher.jkIn

ITEM 614, MAINTAINING TRAFFIC

A MINIMUM OF ONE LANE OF TRAFFIC IN EACH DIRECTION SHALL BE MAINTAINED AT ALL TIMES BY USE OF THE EXISTING PAVEMENT AND THE COMPLETED PAVEMENT. ONE LANE CLOSER PER DIRECTION 8 PM TO 10 PM AND TWO LANE CLOSURES PER DIRECTION PERMITTED 10 PM TO 6 AM

NO WORK SHALL BE PERFORMED AND ALL LANES EXCEPT CENTER LANE SHALL BE OPEN TO TRAFFIC BETWEEN THE HOURS OF 6 AM AND 8 PM.

IN ADDITION, NO WORK SHALL BE PERFORMED AND ALL EXISTING LANES EXCEPT CENTER LANE SHALL BE OPEN TO TRAFFIC DURING THE FOLLOWING DESIGNATED HOLIDAYS OR EVENTS:

CHRISTMAS FOURTH OF JULY
NEW YEARS LABOR DAY
MEMORIAL DAY THANKSGIVING

THE PERIOD OF TIME THAT THE LANES ARE TO BE OPEN DEPENDS ON THE DAY OF THE WEEK ON WHICH THE HOLIDAY OR EVENT FALLS. THE FOLLOWING SCHEDULE SHALL BE USED TO DETERMINE THIS PERIOD:

DAY OF HOLIDAY TIME ALL LANES
OR EVENT MUST BE OPEN TO TRAFFIC

SUNDAY 12:00N FRIDAY THROUGH 6:00AM MONDAY
MONDAY 12:00N FRIDAY THROUGH 6:00AM TUESDAY
TUESDAY 12:00N MONDAY THROUGH 6:00AM WEDNESDAY
WEDNESDAY 12:00N TUESDAY THROUGH 6:00AM THURSDAY
THURSDAY 12:00N WEDNESDAY THROUGH 6:00AM FRIDAY
(THANKSGIVING ONLY)
6:00AM WEDNESDAY THROUGH 6:00AM MONDAY
FRIDAY 12:00N THURSDAY THROUGH 6:00AM MONDAY
SATURDAY 12:00N FRIDAY THROUGH 6:00AM MONDAY

SHOULD THE CONTRACTOR FAIL TO MEET ANY OF THESE REQUIREMENTS, THE CONTRACTOR SHALL BE ASSESSED A DISINCENTIVE OF \$1,000 FOR EACH HOUR OR PART OF AN HOUR FOR EACH LANE THAT IS NOT OPEN TO TRAFFIC.

LENGTH AND DURATION OF LANE CLOSURES AND RESTRICTIONS SHALL BE AT THE APPROVAL OF THE ENGINEER. IT IS THE INTENT TO MINIMIZE THE IMPACT TO THE TRAVELING PUBLIC. LANE CLOSURES OR RESTRICTIONS OVER SEGMENTS OF THE PROJECT IN WHICH NO WORK IS ANTICIPATED WITHIN A REASONABLE TIME FRAME, AS DETERMINED BY THE ENGINEER, SHALL NOT BE PERMITTED. THE LEVEL OF UTILIZATION OF MAINTENANCE OF TRAFFIC DEVICES SHALL BE COMMENSURATE WITH THE WORK IN PROGRESS.

THE CONTRACTOR SHALL PROVIDE, ERECT AND MAINTAIN SIGNS AND SIGN SUPPORTS, AS DETAILED IN THE OHIO MANUAL OF UNIFORM TRAFFIC CONTROL DEVICES, AND TYPE III BARRICADES AS REQUIRED.

ALL WORK AND TRAFFIC CONTROL DEVICES SHALL BE IN ACCORDANCE WITH C&MS 614 AND OTHER APPLICABLE PORTIONS OF THE SPECIFICATIONS, AS WELL AS THE OHIO MANUAL OF UNIFORM TRAFFIC CONTROL DEVICES. PAYMENT FOR ALL LABOR, EQUIPMENT AND MATERIALS SHALL BE INCLUDED IN THE LUMP SUM CONTRACT PRICE FOR ITEM 614, MAINTAINING TRAFFIC, UNLESS SEPARATELY ITEMIZED IN THE PLAN.

THE CONTRACTOR SHALL MAINTAIN EXISTING VEHICLE DETECTION AND INTERCONNECT CABLE OPERATION THROUGHOUT THE CONSTRUCTION PROCESS. IF AT ANY TIME THE INTERCONNECT BECOMES INOPERABLE, THE CONTRACTOR SHALL REPAIR ANY PROBLEMS TO THE SATISFACTION OF THE COUNTY WITHIN EIGHT HOURS OF RECEIVING NOTICE. WHEN A DETECTOR LOOP BECOMES INOPERABLE, THE CONTRACTOR SHALL TEMPORARILY REPAIR THE DAMAGED LOOP IF POSSIBLE. WHEN IT IS NOT POSSIBLE, THE CONTRACTOR SHALL PROVIDE TEMPORARY DETECTION. THIS SHALL CONSIST OF CAMERAS, MICROWAVE UNITS OR OTHER APPROVED DETECTION TYPES TO MAINTAIN THE OPERATION OF THE SIGNAL DETECTION. THE CONTRACTOR SHALL CONTACT THE COUNTY TO OBTAIN ANY REQUIRED TIMING CHANGES TO BE ENTERED UNTIL TEMPORARY DETECTION IS INSTALLED. NOTE THAT NO LOOP DETECTION SHALL BE INOPERABLE FOR MORE THAN 48 HOURS. ANY WORK THAT WILL NECESSITATE CLOSING A LANE SHALL BE COMPLETED BETWEEN THE HOURS OF 10 PM AND 6 AM.

ACCESS TO LOCAL DRIVES

CONTRACTOR SHALL MAINTAIN ACCESS TO LOCAL RESIDENCES AND BUSINESSES WITHIN THE PROJECT AREA THROUGHOUT THE DURATION OF THE PROJECT. COST OF MAINTAINING ACCESS SHALL BE INCIDENTAL TO ITEM 614, MAINTAINING TRAFFIC.

PLACEMENT OF ASPHALT CONCRETE

TWO-WAY TRAFFIC SHALL BE MAINTAINED AT ALL TIMES EXCEPT THAT ONE-WAY TRAFFIC WILL BE PERMITTED FOR MINIMUM PERIODS OF TIME CONSISTENT WITH THE REQUIREMENTS OF THE SPECIFICATIONS FOR PROTECTION OF COMPLETED ASPHALT CONCRETE COURSES.

WORK ZONE MARKINGS AND SIGNS

THE FOLLOWING ESTIMATED QUANTITIES HAVE BEEN CARRIED TO THE GENERAL SUMMARY FOR USE AT LOCATIONS IDENTIFIED BY THE ENGINEER FOR WORK ZONE PAVEMENT MARKINGS AND SIGNS PER THE REQUIREMENTS OF C&MS 614.04 AND 614.11.

- ITEM 614, WORK ZONE LANE LINE, CLASS I, 4", 740.06, TYPE I 0.57 MILE
- ITEM 614, WORK ZONE CENTERLINE, CLASS I, 740.06, TYPE I 0.29 MILE
- ITEM 614, WORK ZONE CHANNELIZING LINE, CLASS I, 8", 740.06, TYPE I 379 FT
- ITEM 614, WORK ZONE STOP LINE, CLASS I, 740.06, TYPE I 85 FT
- ITEM 614, WORK ZONE ARROW, CLASS I, 740.06, TYPE I 6 EACH
- ITEM 614, WORK ZONE WORD ON PAVEMENT, 72", CLASS I, 740.06, TYPE I 6 EACH

FLOODLIGHTING

FLOODLIGHTING OF THE WORK SITE FOR OPERATIONS CONDUCTED DURING NIGHTTIME PERIODS SHALL BE ACCOMPLISHED SO THAT THE LIGHTS DO NOT CAUSE GLARE TO THE DRIVERS ON THE ROADWAY. TO ENSURE THE ADEQUACY OF THE FLOODLIGHT PLACEMENT, THE CONTRACTOR AND THE ENGINEER SHALL DRIVE THROUGH THE WORK SITE EACH NIGHT WHEN THE LIGHTING IS IN PLACE AND OPERATIVE PRIOR TO COMMENCING ANY WORK. IF GLARE IS DETECTED, THE LIGHT PLACEMENT AND SHIELDING SHALL BE ADJUSTED TO THE SATISFACTION OF THE ENGINEER BEFORE WORK PROCEEDS.

PAYMENT FOR ALL LABOR, EQUIPMENT AND MATERIALS SHALL BE INCLUDED IN THE LUMP SUM CONTRACT PRICE FOR ITEM 614, MAINTAINING TRAFFIC.

ITEM 614 - LAW ENFORCEMENT OFFICER (WITH PATROL CAR) FOR ASSISTANCE DURING CONSTRUCTION OPERATIONS

USE OF LAW ENFORCEMENT OFFICERS (LEOS) BY CONTRACTORS OTHER THAN THE USES SPECIFIED BELOW WILL NOT BE PERMITTED AT PROJECT COST. LEOS SHOULD NOT BE USED WHERE THE OMUTCD INTENDS THAT FLAGGERS BE USED.

IN ADDITION TO THE REQUIREMENTS OF C&MS 614 AND THE OMUTCD, A UNIFORMED LEO WITH AN OFFICIAL PATROL CAR (CAR WITH TOP-MOUNTED EMERGENCY FLASHING LIGHTS AND COMPLETE MARKINGS OF THE APPROPRIATE LAW ENFORCEMENT AGENCY) SHALL BE PROVIDED FOR THE FOLLOWING TRAFFIC CONTROL TASKS:

DURING THE ENTIRE ADVANCE PREPARATION AND CLOSURE SEQUENCE WHERE COMPLETE BLOCKAGE OF TRAFFIC IS REQUIRED.

DURING THE TIME WHEN TRAFFIC NEEDS TO BE DIRECTED THROUGH AN ENERGIZED TRAFFIC SIGNAL CONTRARY TO THE SIGNAL DISPLAY (E.G., DIRECTING MOTORISTS THROUGH A RED LIGHT).

IN ADDITION TO THE REQUIREMENT OF C&MS 614 AND THE OMUTCD, A UNIFORMED LEO WITH AN OFFICIAL PATROL CAR (CAR WITH TOP-MOUNTED EMERGENCY FLASHING LIGHTS AND COMPLETE MARKINGS OF THE APPROPRIATE LAW ENFORCEMENT AGENCY) SHOULD BE PROVIDED FOR THE FOLLOWING TRAFFIC CONTROL TASKS AS APPROVED BY THE ENGINEER:

FOR LANE CLOSURES: DURING INITIAL SET-UP PERIODS, TEAR DOWN PERIODS, SUBSTANTIAL SHIFTS OF A CLOSURE POINT OR WHEN A NEW LANE CLOSURE ARRANGEMENTS ARE INITIATED FOR LONG-TERM LANE CLOSURES/SHIFTS (FOR THE FIRST AND LAST DAY OF MAJOR CHANGES IN TRAFFIC CONTROL SETUP).

IN GENERAL, LEOS SHOULD BE POSITIONED IN ADVANCE OF AND ON THE SAME SIDE AS THE LANE RESTRICTION OR AT THE POINT OF ROAD CLOSURE, AND TO MANUALLY CONTROL TRAFFIC MOVEMENTS THROUGH SIGNALIZED INTERSECTIONS IN WORK ZONES.

LEOS SHOULD NOT FORGO THEIR TRAFFIC CONTROL RESPONSIBILITIES TO APPREHEND MOTORISTS FOR ROUTINE TRAFFIC VIOLATIONS. HOWEVER, IF A MOTORIST'S ACTIONS ARE CONSIDERED TO BE RECKLESS, THEN PURSUIT OF THE MOTORIST IS APPROPRIATE.

THE LEOS WORK AT THE DIRECTION OF THE CONTRACTOR. THE CONTRACTOR IS RESPONSIBLE FOR SECURING THE SERVICES OF THE LEOS WITH THE APPROPRIATE AGENCIES AND COMMUNICATING THE INTENTIONS OF THE PLANS WITH RESPECT TO DUTIES OF THE LEOS. THE ENGINEER SHALL HAVE FINAL CONTROL OVER THE LEOS' DUTIES AND PLACEMENT, AND WILL RESOLVE ANY ISSUES THAT MAY ARISE BETWEEN THE TWO PARTIES.

ENSURE PROVIDED LEOS HAVE BEEN TRAINED APPROPRIATE TO THE JOB DECISIONS THEY ARE REQUIRED TO MAKE WHILE ON THE PROJECT, IN ACCORDANCE WITH C&MS 614.03.

THE LEO SHALL REPORT IN TO THE CONTRACTOR PRIOR TO THE START OF THE SHIFT, IN ORDER TO RECEIVE INSTRUCTIONS REGARDING THE SPECIFIC WORK ASSIGNMENTS DURING HIS/HER SHIFT. THE LEO IS EXPECTED TO STAY AT THE PROJECT SITE FOR THE ENTIRE DURATION OF HIS/HER SHIFT. THE LEO SHALL REPORT TO THE CONTRACTOR AT THE END OF HIS/HER SHIFT. SHOULD IT BE NECESSARY TO LEAVE THE PROJECT SITE, THE LEO SHALL NOTIFY THE ENGINEER. THE CONTRACTOR SHALL PROVIDE THE LEO WITH A TWO-WAY COMMUNICATION DEVICE WHICH SHALL BE RETURNED TO THE CONTRACTOR AT THE END OF HIS/HER SHIFT.

LEOS (WITH PATROL CAR) REQUIRED BY THE TRAFFIC MAINTENANCE TASKS ABOVE SHALL BE PAID FOR ON A UNIT PRICE (HOURLY) BASIS UNDER ITEM 614, LAW ENFORCEMENT OFFICER (WITH PATROL CAR) FOR ASSISTANCE. THE FOLLOWING ESTIMATED QUANTITIES HAVE BEEN CARRIED TO THE GENERAL SUMMARY:

ITEM 614, LAW ENFORCEMENT OFFICER WITH PATROL CAR FOR ASSISTANCE 200 HOURS

THE HOURS PAID SHALL INCLUDE ANY MINIMUM SHOW-UP TIME REQUIRED BY THE LAW ENFORCEMENT AGENCY INVOLVED.

ANY ADDITIONAL COSTS (ADMINISTRATIVE OR OTHERWISE) INCURRED BY THE CONTRACTOR TO OBTAIN THE SERVICES OF A LEO ARE INCLUDED WITH THE BID UNIT PRICE FOR ITEM 614, LAW ENFORCEMENT OFFICER WITH PATROL CAR FOR ASSISTANCE.

CALCULATED
CAL
CHECKED
DLW

MAINTENANCE OF TRAFFIC GENERAL NOTES

WAR-21-0.23

G:\Cincinnati\Projects\TRN\60603899_WCTID_CR2\000T\WAR\09613\Design\Roadway\Sheets\09613_GN003.dgn Sheet 2/11/2020 8:56:16 AM christopher.jykins

NOTIFICATION OF TRAFFIC RESTRICTIONS

THROUGHOUT THE DURATION OF THE PROJECT, THE CONTRACTOR SHALL NOTIFY THE PROJECT ENGINEER IN WRITING OF ALL TRAFFIC RESTRICTIONS AND UPCOMING MAINTENANCE OF TRAFFIC CHANGES. THE CONTRACTOR SHALL ENSURE THE WRITING OF ALL TRAFFIC RESTRICTIONS AND UPCOMING MAINTENANCE OF TRAFFIC CHANGES. THE CONTRACTOR SHALL ENSURE THE WRITTEN NOTIFICATION IS SUBMITTED IN A TIMELY MANNER TO ALLOW THE PROJECT ENGINEER TO MEET THE REQUIRED TIME FRAMES SET FORTH IN THE TABLE BELOW TO INFORM THE SPECIAL HAULING PERMITS SECTION ([HTTP://WWW.WCEO.US/OPERATIONS/PERMITS.ASPX](http://www.wceo.us/operations/permits.aspx)) AND THE WARREN COUNTY ENGINEER'S OFFICE (WCEO). THIS NOTIFICATION SHALL BE RECEIVED BY THE PROJECT ENGINEER PRIOR TO THE PHYSICAL SETUP OF ANY APPLICABLE SIGNS OR MESSAGE BOARDS.

INFORMATION SHOULD INCLUDE, BUT IS NOT LIMITED TO, ALL CONSTRUCTION ACTIVITIES THAT IMPACT OR INTERFERE WITH TRAFFIC AND SHALL LIST THE SPECIFIC LOCATION, TYPE OF WORK, ROAD STATUS, DATE AND TIME OF RESTRICTION, DURATION OF RESTRICTION, NUMBER OF LANES MAINTAINED, NUMBER OF LANES CLOSED, MINIMUM VERTICAL CLEARANCE, MINIMUM WIDTH OF DRIVABLE PAVEMENT, DETOUR ROUTES, IF APPLICABLE, AND ANY OTHER INFORMATION REQUESTED BY THE PROJECT ENGINEER.

NOTIFICATION TIME TABLE

ITEM	DURATION OF CLOSURE	NOTICE DUE TO PERMITS & PIO
RAMP & ROAD CLOSURES	>= 2 WEEKS	21 CALENDAR DAYS PRIOR TO CLOSURE
	> 12 HOURS & < 2 WEEKS	14 CALENDAR DAYS PRIOR TO CLOSURE
	< 12 HOURS	4 CALENDAR DAYS PRIOR TO CLOSURE
LANE CLOSURES & RESTRICTIONS	>= 2 WEEKS	14 CALENDAR DAYS PRIOR TO CLOSURE
	< 2 WEEKS	5 BUSINESS DAYS PRIOR TO CLOSURE
START OF CONSTRUCTION & TRAFFIC PATTERN CHANGES	N/A	14 CALENDAR DAYS PRIOR TO IMPLEMENTATION

ANY UNFORESEEN CONDITIONS NOT SPECIFIED IN THE PLANS REQUIRING TRAFFIC RESTRICTIONS SHALL ALSO BE REPORTED TO THE PROJECT ENGINEER USING THE NOTIFICATION TIME TABLE.

SUGGESTED SEQUENCE OF CONSTRUCTION

DURING NIGHT TIME HOURS, MILL CENTER LANE TO PREPARE FOR CONCRETE MEDIAN. CONSTRUCT CONCRETE MEDIAN. MILL AND FILL INDIVIDUAL TRAFFIC LANES ONE-BY-ONE WHILE MAINTAINING TRAFFIC. PLACE PAVEMENT MARKINGS AND SIGNS.

CALCULATED
CAL
CHECKED
DLW

MAINTENANCE OF TRAFFIC GENERAL NOTES

WAR-21-0.23



G:\Cincinnati\Projects\TRN\60603899_WCID.CR2\000T.WAR\09613\Design\Roadway\Sheets\09613_G001.dgn_Sheet 2/11/2020 8:56:17 AM christopher.jenkins

SHEET NUMBER										PARTICIPATION				ITEM	ITEM EXT	GRAND TOTAL	UNIT	DESCRIPTION	SEE SHEET NO.
																		PAVEMENT	
														254	01000	7418	SY	PAVEMENT PLANING, ASPHALT CONCRETE, 2"	
														407	20000	641	GAL	NON-TRACKING TACK COAT	
														609	72000	295	SY	CONCRETE MEDIAN	
														442	10000	395	CY	ASPHALT CONCRETE SURFACE COURSE, 12.5MM, TYPE A (446)	
																		TRAFFIC CONTROL	9
														620	60000	35	EACH	DELINEATOR, POST SURFACE MOUNTED	
														621	00100	77	EACH	RPM	
														621	54000	77	EACH	RAISED PAVEMENT MARKER REMOVED	
														630	03100	130	FT	GROUND MOUNTED SUPPORT, NO. 3 POST	
														630	08600	10	EACH	SIGN POST REFLECTOR	
														630	80100	57	SF	SIGN, FLAT SHEET	
														630	84900	7	EACH	REMOVAL OF GROUND MOUNTED SIGN AND DISPOSAL	
														630	86002	5	EACH	REMOVAL OF GROUND MOUNTED POST SUPPORT AND DISPOSAL	
														642	01290	8	EACH	LANE ARROW	
														642	01390	4	EACH	WORD ON PAVEMENT, 72"	
														644	00204	0.54	MILE	LANE LINE, 6"	
														644	00300	0.29	MILE	CENTER LINE	
														644	00404	372	FT	CHANNELIZING LINE, 12"	
														644	00500	85	FT	STOP LINE	
														644	00700	62	FT	TRANSVERSE/DIAGONAL LINE	
														644	01510	23	FT	DOTTED LINE, 6"	
														644	01520	169	FT	DOTTED LINE, 12"	
																		MAINTENANCE OF TRAFFIC	4
														614	11110	200	HOURL	LAW ENFORCEMENT OFFICER WITH PATROL CAR FOR ASSISTANCE	
														614	20200	0.57	MILE	WORK ZONE LANE LINE, CLASS I, 740.06, TYPE I	
														614	21200	0.29	MILE	WORK ZONE CENTER LINE, CLASS I, 740.06, TYPE I	
														614	23400	379	FT	WORK ZONE CHANNELIZING LINE, 8", CLASS I, 740.06, TYPE I	
														614	26400	85	FT	WORK ZONE STOP LINE, CLASS I, 740.06, TYPE I	
														614	30400	6	EACH	WORK ZONE ARROW, CLASS I, 740.06, TYPE I	
														614	31400	6	EACH	WORK ZONE WORD ON PAVEMENT, 72", CLASS I, 740.06, TYPE I	
																		INCIDENTALS	
														614	11000	LS		MAINTAINING TRAFFIC	4
														623	10000	LS		CONSTRUCTION LAYOUT STAKES AND SURVEYING	3
														624	10000	LS		MOBILIZATION	

CALCULATED	CAL	CHECKED	DLW
GENERAL SUMMARY			
WAR-21-0.23			



G:\Cincinnati\Projects\TRN\60603899_WCID.CR21\0001\WAR\09613\Design\Roadway\Sheets\09613.GP001.dgn Sheet 2/11/2020 8:56:21AM christopher.lykins

CALCULATED
 CAL
 CHECKED
 DLW

0 20 40
 HORIZONTAL
 SCALE IN FEET

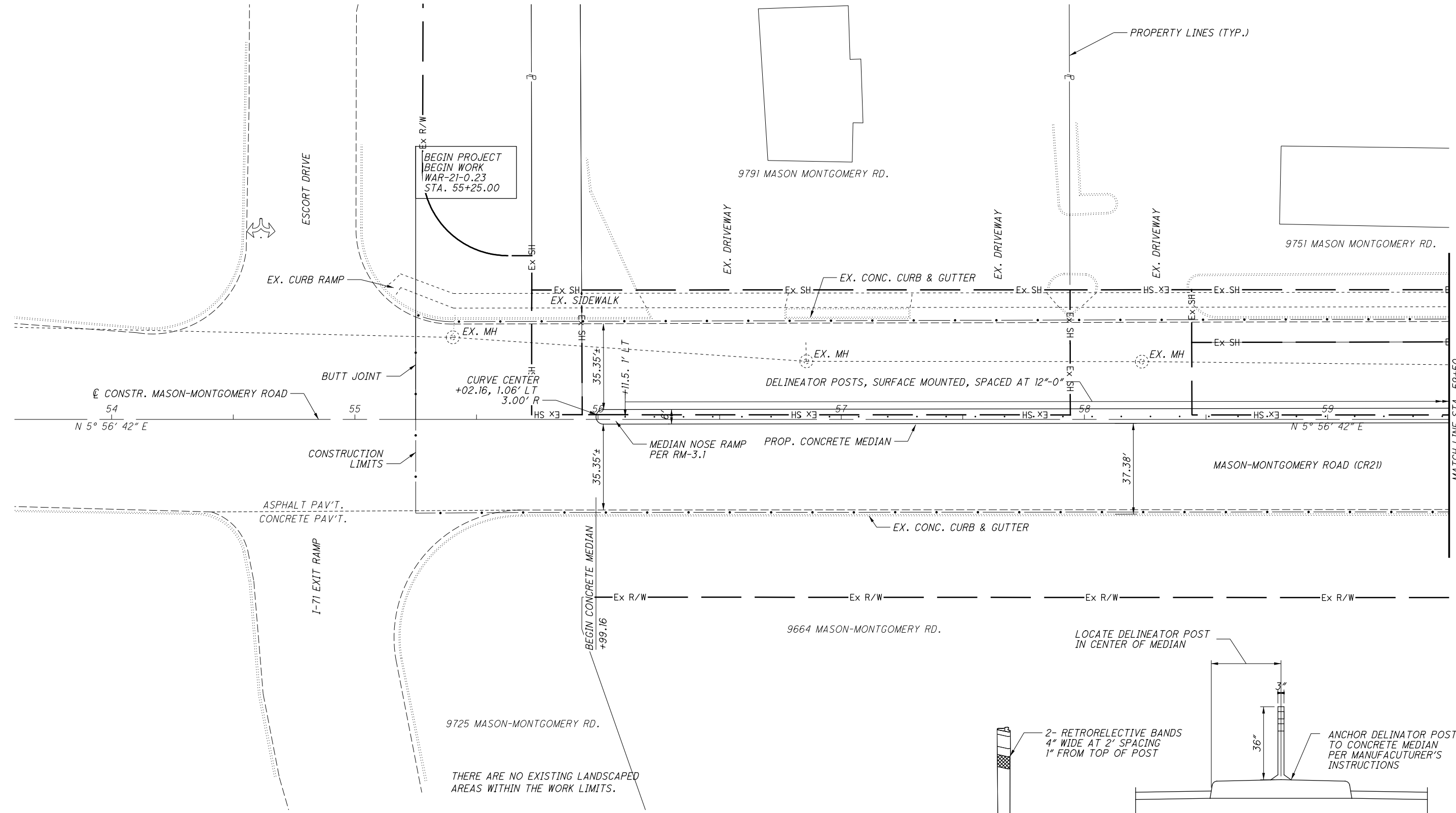

NOTE:
 ALL PROPERTY AND RIGHT OF WAY LINES SHOWN ARE APPROXIMATIONS BASED ON COUNTY AUDITOR INFORMATION ANDE DOES NOT REPRESENT A BOUNDARY SURVEY.

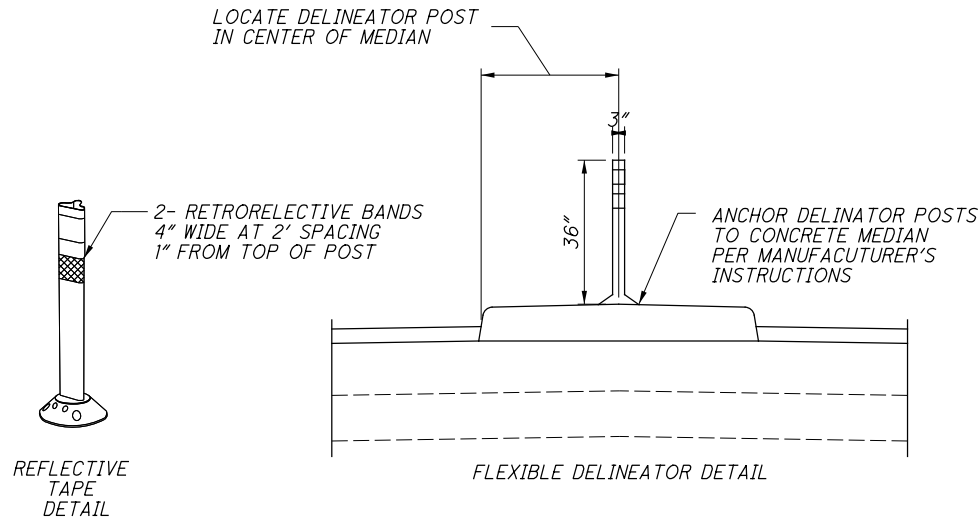

PLAN
 BEGIN PROJECT TO STA. 59+50

WAR-21-0.23

G:\Cincinnati\DCS\Projects\TRN\60603899_WCID\CR2\0001\WAR\09613\Design\Roadway\Sheets\09613.GP002.dgn Sheet 2/11/2020 8:56:23 AM christopher.lykins

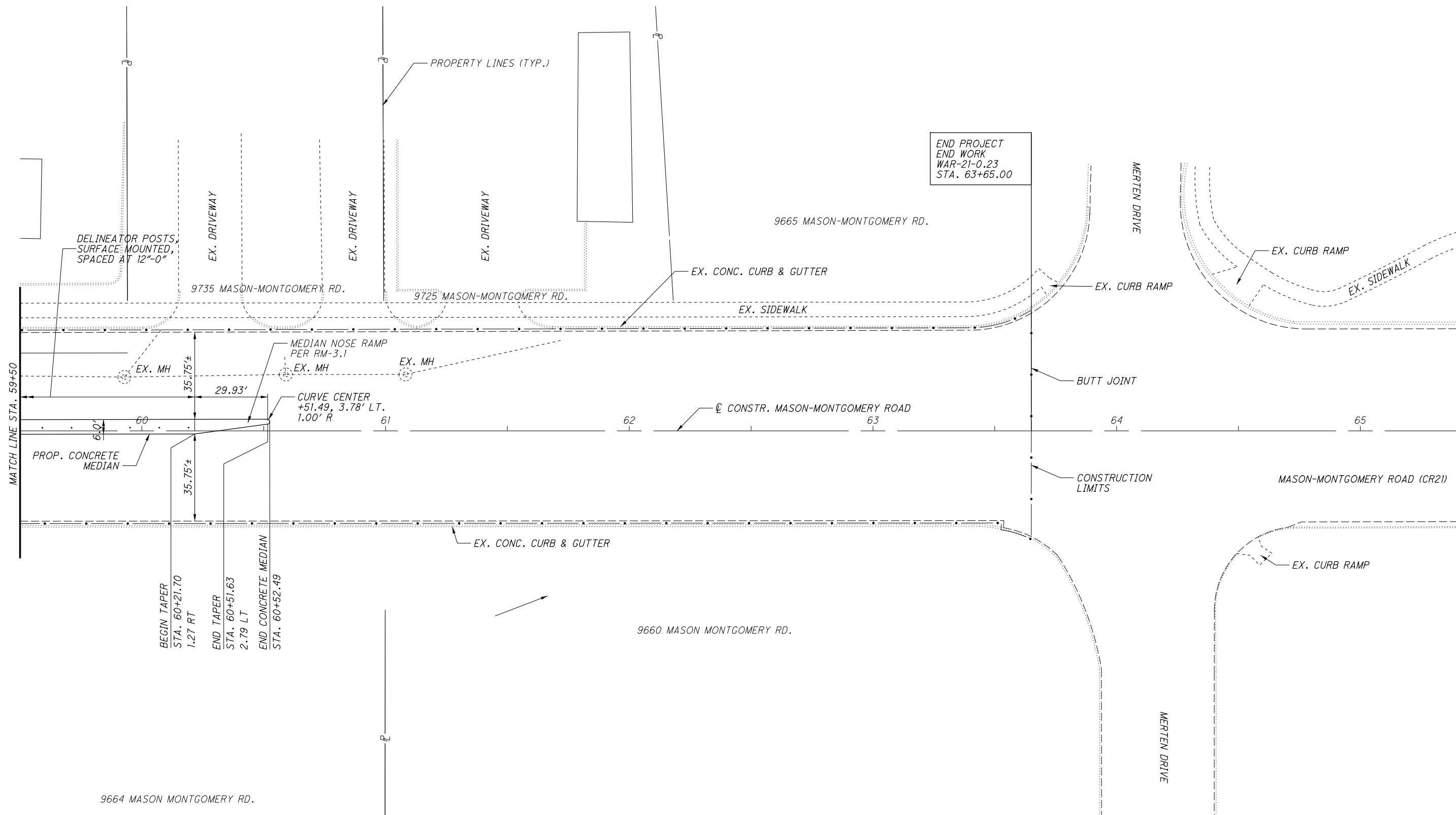

NOTE:
ALL PROPERTY AND RIGHT OF WAY LINES SHOWN ARE APPROXIMATIONS BASED
ON COUNTY AUDITOR INFORMATION AND DOES NOT REPRESENT A BOUNDARY SURVEY.

CALCULATED
CAL
CHECKED
DLW

0 20 40
HORIZONTAL
SCALE IN FEET

PLAN
STA. 59+50 TO END PROJECT

WAR-21-0.23

8
9

G:\Cincinnati\Projects\TRN\60603899_WCID_CR2\000T\WAR\09613\Design\Traffic\Sheets\09613_TP001.dgn Sheet 2/11/2020 8:56:27 AM christopher.jenkins

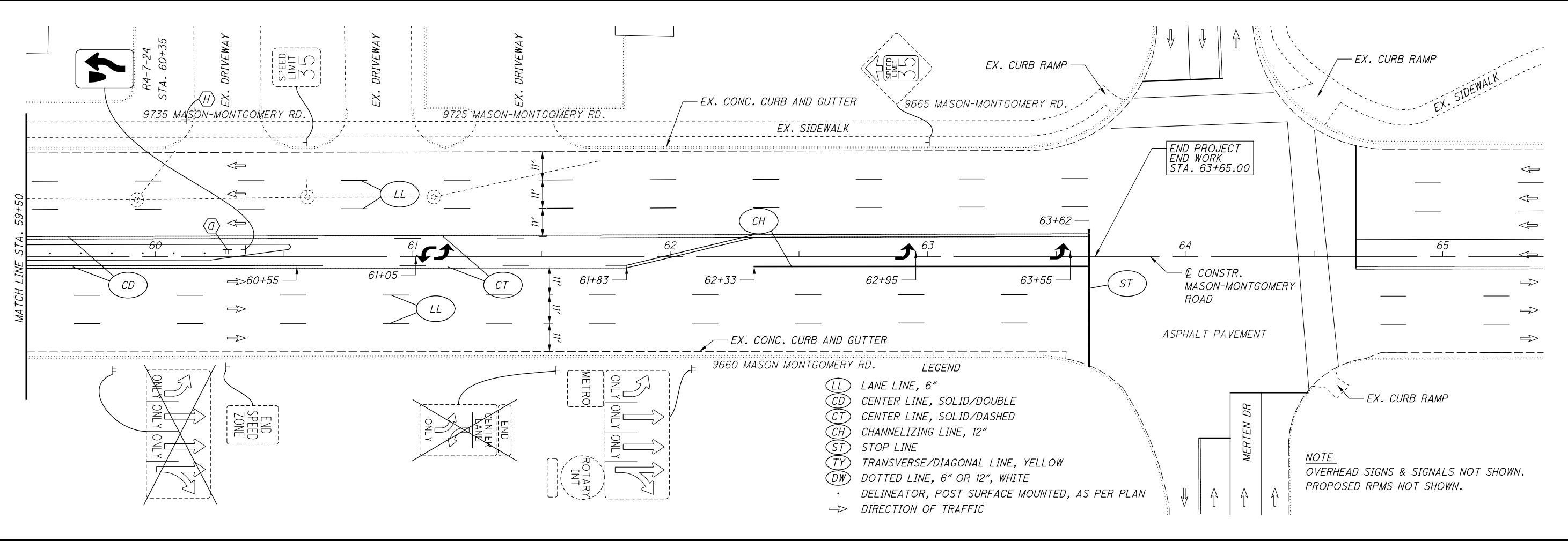
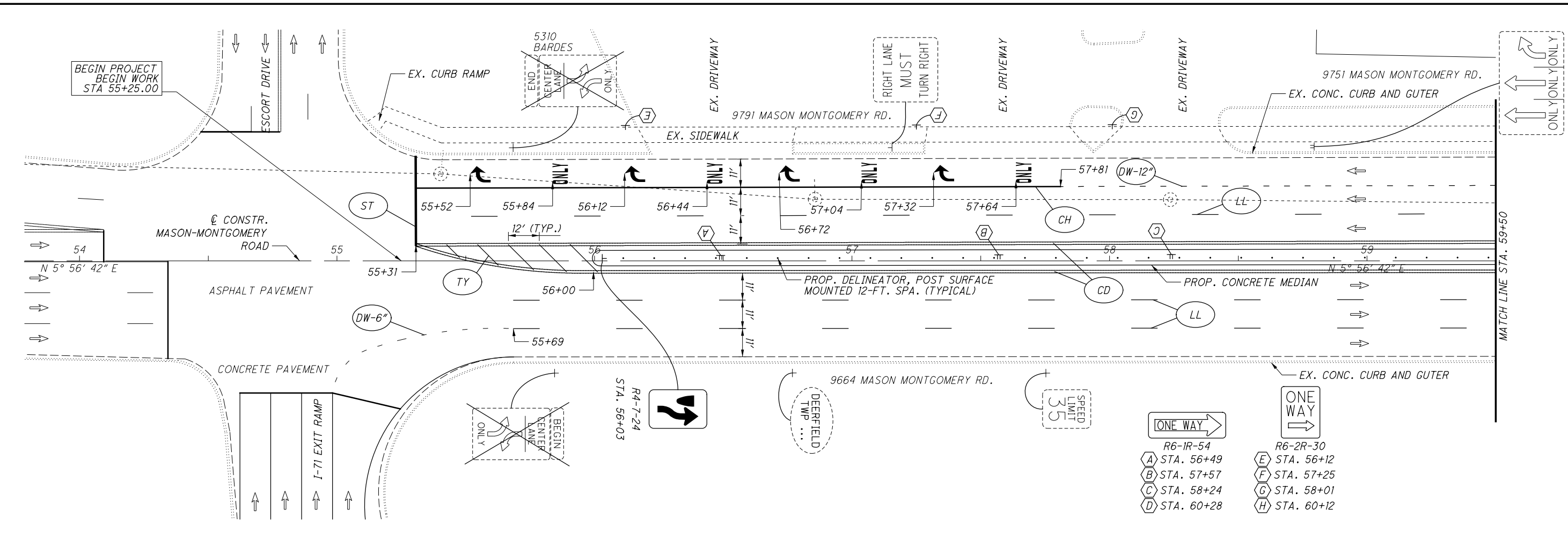

- LEGEND**
- (LL) LANE LINE, 6"
 - (CD) CENTER LINE, SOLID/DOUBLE
 - (CT) CENTER LINE, SOLID/DASHED
 - (CH) CHANNELIZING LINE, 12"
 - (ST) STOP LINE
 - (TY) TRANSVERSE/DIAGONAL LINE, YELLOW
 - (DW) DOTTED LINE, 6" OR 12", WHITE
 - DELINEATOR, POST SURFACE MOUNTED, AS PER PLAN
 - ➔ DIRECTION OF TRAFFIC

- | | |
|----------------|----------------|
| (A) STA. 56+49 | (E) STA. 56+12 |
| (B) STA. 57+57 | (F) STA. 57+25 |
| (C) STA. 58+24 | (G) STA. 58+01 |
| (D) STA. 60+28 | (H) STA. 60+12 |

R6-1R-54

R6-2R-30

NOTE
OVERHEAD SIGNS & SIGNALS NOT SHOWN.
PROPOSED RPMS NOT SHOWN.

N

0 20 40

HORIZONTAL SCALE IN FEET

CALCULATED

CAL

CHECKED

DLW

SIGNING AND PAVEMENT MARKING PLAN

9

WAR-21-0.23

9